

Revision of the subgenus *Coeloprosopus* CHAUDOIR of the ground beetle genus *Pericalus* MACLEAY. Taxonomy, phylogeny, zoogeography.

(Coleoptera, Carabidae, Lebiinae) *

by Martin BAEHR

Abstract

The arboreal Oriental-Australian Region subgenus *Coeloprosopus* CHAUDOIR of the genus *Pericalus* MACLEAY is revised. Typical material of most species has been compared. Based on external features of adults and on details of the male genitalia, the 18 species are keyed, characterized and classified. Lectotypes and eventually paralectotypes are designated for the following species: *Pericalus figuratus* CHAUDOIR, *P. gratus* SCHAUM, *P. klapperichi* JEDLICKA, *P. laetus* SCHAUM, *P. levifrons* HELLER, *P. philippinus* HELLER, *P. tetrastigma* CHAUDOIR, *P. undatus* CHAUDOIR, and *P. xanthopus* SCHAUM.

P. macrostictus LOUWERENS is synonymized with *P. klapperichi* JEDLICKA, and *P. spiniger* ANDREWES is synonymized with *P. picturatus* CHAUDOIR. The following species have been newly described: *Pericalus atricornis*, sp. n. from Sumatra, *P. robustus*, sp. n. from Java, *P. magnus*, sp. n. from Sulawesi (Celebes), *P. angusticollis*, sp. n. from Sarawak (Borneo), and *P. cuprascens*, sp. n. from Irian Jaya (New Guinea).

A phylogenetic analysis using the methods proposed by W. HENNIG shows that most species with the greater number of plesiomorphic character states occur in the South Asian mainland, on the Greater Sunda Islands, and on Palawan (i. e. west of WALLACE's line), whereas the species or even species-groups with the greater number of apomorphic character states occur in general on the islands to the east of this line (Philippines, Sulawesi, New Guinea, and New Britain), i. e. at the eastern and southeastern margin of the common range of the genus. Chorological evidence of the whole genus reveals that these marginal areas (Wallacea and Papuan subregion) are only inhabited by species of the more apomorphic subgenus *Coeloprosopus*, whereas the plesiomorphic nominate subgenus ranges west of WALLACE's line. From that distributional and phylogenetical pattern the history of the genus may be derived. Presumably the genus originated on the South Asian mainland, probably in Indochina, from where species of the nominate subgenus spread southerly to the Greater Sunda Islands, and westerly and easterly to India and Taiwan, respectively. The subgenus *Coeloprosopus*, however, originated presumably in the so-called Sundaland (southern Malaysia, Sumatra, Java, Borneo), where still many plesiomorphic species persist. The highly apomorphic species-groups are found only in the Wallacea and the Papuan subregion to the east and southeast, where they split into several closely related, but highly evolved species, causing a surprisingly high species diversity in the mentioned areas. Phylogenetical and chorological evidence reveals, however, that at least one species-group recolonized Sundaland from the Wallacea and crossed WALLACE's line from the east to west.

Introduction

My interest on the genus *Pericalus* arose when I received several *Pericalus* specimens from A. RIEDEL that I was unable to identify by use of the current literature. Since the sample included some rather unusual species, I became soon displeased about that deficiency. So I first started a provisional review that later became a regular revision, as my interest grew according to increasing comprehension of the fascinating phylogenetic and biogeographic problems in this genus.

* in part results of the collections of A. RIEDEL in New Guinea 1990-1994

Pericalus is a genus of conspicuously large-eyed ground beetles externally rather similar to the genus *Catascopus* KIRBY, but distinguished from that genus by the absence of the mental tooth and by the short and wide, posteriorly even widened elytra. *Pericalus* is perhaps more closely related to the genus *Coptodera* DEJEAN (s. l.) with which some authors (e. g. BALL 1975, BALL & SHPELEY 1993) combine it in the same subtribe Pericalina. BASILEWSKY (1984), although stating the close relationships of both genera, nevertheless ranked them in two distinct subtribes Pericalina and Coptoderina.

Most species of *Pericalus*, but generally those of the subgenus *Coeloprosoopus*, bear a pattern of two variously shaped yellow or reddish elytral spots or groups of spots on green, blue, purplish or black ground. All species are characterized by their large, markedly projecting eyes that give them a remarkably cindeloid habitus.

The genus is distributed throughout the Oriental region from India to Taiwan and south to Sulawesi (Celebes) and the Philippine Islands. It transgresses the borders of this region in New Guinea and New Britain, but does not reach Australia. Species density is presumably greatest in the Greater Sunda Islands, the Philippines, and in Sulawesi, less so on the Asiatic mainland and in the Australian region.

Generally, the species occur in forested country, especially in rain forest, where they live mainly on tree trunks and fallen logs. Similar to the species of the genus *Catascopus*, they are very sharp-sighted, agile runners.

The genus comprises two easily divided, well founded subgenera. The subgenus *Pericalus* s. str. (12 described species) includes generally larger, depressed, less metallic species bearing a rather wide, heart-shaped pronotum with wide, depressed lateral channel but raised border. The subgenus *Coeloprosoopus* (17 described species) comprises commonly smaller, more convex, usually highly metallic greenish species bearing a narrower, less heart-shaped pronotum with convex disk and very narrow lateral channel. All known species of *Coeloprosoopus* bear an elytral pattern on metallic or blackish ground.

The species of the nominate subgenus are generally fairly easily distinguished. Most species of the subgenus *Coeloprosoopus*, however, are very closely related and they make up some slightly different species-groups. Within these groups species distinction is highly difficult, because many species are very closely related and some species vary to a considerable degree in size, colour, and pattern, and some names are even synonymous. Because at present species are mainly differentiated by colour and pattern, determinations are often not satisfactory. Hence an attempt has been made to include the male genitalia as a means to get a more objective knowledge of the species.

Unfortunately, types or ♂ specimens were not available in some species. Hence, those species have been included in the key on the basis of the original descriptions only.

Material

Type material of the following named species has been considered: *adonis* SCHAUFUSS, *depressus* ANDREWES, *figuratus* CHAUDOIR, *gratus* SCHAUM, *klapperichi* JEDLICKA, *laetus* SCHAUM, *levifrons* HELLER, *philippinus* HELLER, *picturatus* CHAUDOIR, *spiniger* ANDREWES, *tetrastigma* CHAUDOIR, *undatus* CHAUDOIR, and *xanthopus* SCHAUM.

Non-typical material only was available from the following species: *macrostictus* LOUWERENS, *quadri-maculatus* MACLEAY, and *signatus* JEDLICKA.

Altogether, 317 specimens have been examined.

Abbreviations of collections mentioned in text

BMNH	The Natural History Museum, London
CBM	Collection M. BAEHR, München
FMT	Museum G. FREY, München
MNHB	Museum für Naturkunde der Humboldt-Universität, Berlin
MNHN	Museum National d'Histoire Naturelle, Paris
NHMB	Naturhistorisches Museum, Basel
NHMW	Naturhistorisches Museum, Wien
NMNHPr	National Museum of Natural History, Praha
SMNS	Staatliches Museum für Naturkunde, Stuttgart
SMTD	Staatliches Museum für Tierkunde, Dresden

Measurements

Measurements have been taken using an ocular micrometer. Length of body has been measured from tip of labrum to apex of elytra including the elytral spines. Hence, measurements may slightly differ from those in the literature. To accommodate the measured ratio of width/length of the prothorax with the optical impression, length of prothorax has been measured from tip of anterior angles to apex of posterior angles, not along middle!

Characters

Good characters for separating of many species are offered by shape and structure of the male genitalia, especially of degree of twisting of aedeagus and shape of the apex, to a lesser degree also of shape of parameres and genital ring. The internal sac is rather simply coiled, but apparently it does not yield any conspicuous and taxonomically valuable features like spines or other sclerites. Degree of microreticulation, striolation and puncturation of the surface of head, pronotum, and elytra offer also useful and somewhat stable differentiating characters. Form of pronotum, especially shape of the posterior angles, and shape of the elytra are useful, though may vary to some degree, and the elytra show some sexual variation, because the female elytra of most species are distinctly widened posteriorly and more or less compressed in anterior third. Ground colour of dorsal surface, colour of appendages, and structure of elytral pattern are basically characteristic for many species and species-groups, but they may also vary to some degree. This is especially critical in those species-groups including very closely related species.

There are some minor characters useful for the differentiation of certain species that should be used, however, with some precaution: Degree of convexity of elytra; depth of elytral striae and degree of convexity of intervals; length of apical elytral spines; depth of transverse sulci of pronotum, etc.

♀ genitalia (Fig. 1f). The stylomeres are highly apomorphic, but very similar throughout the subgenus and do not offer good distinguishing characters.

Because most descriptions are based on external characters only like shape, colour, and pattern, and the descriptions of few species only are detailed, most species are extensively redescribed. Special attention is paid herein to microreticulation of surface of head, pronotum, and elytra, and to characters of the ♂ genitalia.

Taxonomic principles

Many taxa of the subgenus *Coeloprosopus* are certainly very closely related and hence, the question arises, whether they might be classified as species or as subspecies. I have always adopted the species category, because it is much more difficult to define subspecies than species, especially in mostly insular populations. I recognize that for example the *quadrinaculatus*-lineage is composed of taxa some of them might be as well taken for subspecies as for species from the morphological point of view. However, because they are partly sympatric, these taxa are regarded as species.

The subgenus *Coeloprosopus* is certainly a monophyletic unit, but I do not care about the category of this unit and adopt a conservative attitude regarding it a subgenus. For further subdivision some "species-groups" are distinguished that are assemblages of related species and hopefully form monophyletic units. These species-groups can be further subdivided in monophyletic subgroups and such grouping is used in the biogeographical part of this paper.

Geographical remarks

The geographic range of the genus *Pericalus* covers the south Asian mainland and the Indomalayan islands southeast towards New Guinea and New Britain. For the subsequent biogeographical considerations it should be stressed that this area is composed of certain subregions of rather different geological history and provenience: namely mainland Asia except for southern Malaysia and Thailand; the so-called "Sunda

© Münchner Ent. Ges., Download from The BHL <http://www.biodiversitylibrary.org/>; www.biologiezentrum.at
 Plateau" or "Sundaland" that covers southern Malaysia, southern Thailand, and the Greater Sunda Islands including Palawan (the most westerly island of the Philippines); the so-called Wallacea that covers the islands east to WALLACE's line, namely the Philippines, Sulawesi, Halmahera, and Ceram; and the islands of the Papuan subregion, namely New Guinea and New Britain with some neighbouring smaller islands. WALLACE's line marks the eastern border of the Asian continental shelf and most areas west of this line have been more or less tightly connected with the mainland in the not-distant past, whereas the islands to the east of this line have been never connected with the Asian mainland.

Of the four different subregions, at least three (Sundaland, the Wallacea, and the Papuan subregion) are of southern origin and reached their present position as drifting terranes during different periods of the Tertiary. Hence their original flora and fauna is of southern (Gondwanan) origin and not until reaching their recent position faunal interchange with the Asian mainland took place.

Genus *Pericalus* MACLEAY

MACLEAY, 1825, p. 15; SCHMIDT-GÖBEL 1846, p. 85; LACORDAIRE 1854, p. 147; SCHAUM 1860, p. 190; CHAUDOIR 1861, p. 123; 1869, p. 158; DUPUIS 1913, p. 82; CSIKI 1932, p. 1368; JEDLICKA 1963, p. 373; DARLINGTON 1968, p. 110.

Type species: *Pericalus cicindeloides* MACLEAY, 1825

Subgenus *Coeloprosopus* CHAUDOIR

CHAUDOIR, 1842, p. 849; CSIKI 1932, p. 1368.

Type species: *Catascopus quadrimaculatus* MACLEAY, 1825

The subgenus is mainly characterized by the convex pronotum with narrow lateral margins and narrow marginal channel; furthermore by more convex build, almost always metallic surface, and the presence of an elytral pattern composed of two light spots of different size and shape.

♂ genitalia. Genital ring usually elongate, rather parallel, apex more or less rounded. Aedeagus narrow and elongate, in ventral view more or less markedly sinuate, apex simple or to some extent thickened or hook-shaped, slightly curved down, curvature sometimes faintly angulate. Parameres very dissimilar, left paramere large and rather elongate, right paramere markedly shortened.

♀ genitalia (Fig. 1f). Stylomere 2 very slender and elongate, at apex curved and acute, with 3, rarely unilaterally 2 ventral ensiform seta, a preapical dorsal ensiform seta, but without nematiform seta(e). Stylomere 2 without any setae at apex. Lateral plate partly concealing stylomere 1, asetose.

At present 18 species included that occur from Malaysia and Thailand on the Asian mainland through the Greater Sunda Islands, some of the lesser Sunda Islands, the Philippines, Sulawesi (Celebes), Halmahera, New Guinea, and New Britain. The species are tentatively arranged into species-groups that confidently form monophyletic units, though some groups can be further divided into subgroups.

Key to the species of the subgenus *Coeloprosopus* CHAUDOIR of the genus *Pericalus*

1. Pattern consisting of 2 rather circular spots 2.
- Pattern consisting of 2 triangular or more or less transverse spots or stripes, the anterior one being more or less serrate and anteriorly distinctly excised (doubtful species under both couplets) 13.
2. Elytra completely blue or violaceous; elytral spots small, only 2 (rarely 3) intervals wide; legs completely dark. Malaysia, Sumatra, Borneo 3.
- Elytra usually not completely blue or violaceous; elytral spots variable, commonly larger; legs not completely dark 4.

3. Smaller species, <8.5 mm; microreticulation of pronotum weaker; elytral striae deep. Malaysia, Sumatra, Borneo 7. *tetrastigma* CHAUDOIR
 – Larger species, >10.0 mm; microreticulation of pronotum strong; elytral striae shallow. Sumatra 8. *atricornis*, sp. n.
4. Anterior elytral spot usually only 2-3 intervals wide (on 3th-5th or on 4th-6th intervals), in latter case rarely overlapping to the external part of 3rd interval 5.
 – Anterior elytral spot at least 4 intervals wide (on 4th-7th intervals), or even wider (doubtful species under both couplets) 10.
5. Large species, >10 mm long; intervals depressed at least in centre of elytra, median striae shallow; elytral spots reddish, rather faded; aedeagus markedly sinuate, apex bent down (Fig. 6). Sulawesi (Celebes) 6. *magnus*, sp. n.
 – Smaller species, <9,2 mm long; intervals usually convex, even in centre of elytra; aedeagus different, or unknown, or, if rather similar, species <7.5 mm long 6.
6. Larger species, >8 mm long 7.
 – Smaller species, <7.5 mm long 8.
7. Elytra wide, posteriorly ampliate; anterior elytral spot 3 intervals wide, outer part (on 6th interval) not much shorter than inner; aedeagus slightly sinuate, apex straight, elongate, acute, evenly curved (Fig. 4). Sulawesi (Celebes) 4. *laetus* SCHAUM
 – Elytra posteriorly less ampliate; anterior elytral spot 3 intervals wide, outer part (on 6th interval) distinctly shorter than inner; aedeagus almost straight, apex oblique, short and stout, slightly convex, upper surface with edge (Fig. 2). Java 2. *robustus*, sp. n.
8. Aedeagus remarkably sinuate and with distinctly hooked apex (Fig. 5). Sulawesi (Celebes) 5. *gratus* SCHAUM
 – Aedeagus far less sinuate and with less distinctly hooked apex. SE Asia south to Borneo, Philippine Islands 9.
9. Genital ring apically symmetric; aedeagus barely sinuate, apex obtuse, evenly deflexed ventrally (Fig. 1). Malaysia, Burma, Thailand, Sumatra, Java, Borneo 1. *quadrimaculatus* (MACLEAY)
 – Genital ring apically asymmetric; aedeagus slightly sinuate, apex acute, slightly bent, upper surface with slight edge (Fig. 3). Philippine Islands: Palawan, Samar 3. *signatus* JEDLICKA
10. Frons almost devoid of microreticulation, sparsely punctate; elytra very convex, black throughout; most of antennae, tibiae, tarsi, and apical half of posterior femora black; both elytral spots wide (on 3rd-8th striae) and large, anterior spot circular (Fig. 26); aedeagus unknown. Philippine Islands: Mindanao 9. *levifrons* HELLER
 – Frons with distinct reticulation; elytra less convex, green, or green and in middle black, or blackish but then fore body cupreous; antennae and legs yellowish; elytral spots variable, 4-6 intervals wide, anterior spot commonly more triangular. Distribution different 11.
11. Anterior elytral spot circular, not incised anteriorly (Fig. 17, 18) and colour of elytra green or greenish-cupreous and aedeagus barely sinuate, apex obtuse, evenly deflexed ventrally (Fig. 1). Malaysia, Burma, Thailand, Sumatra, Java, Borneo 1. *quadrimaculatus* (MACLEAY)
 – Anterior elytral spot slightly triangular, anteriorly incised (Figs 30, 31) and colour of elytra blackish-green or blackish and aedeagus distinctly sinuate and apex rather bent down (Figs 11, 12). New Guinea, New Britain 12.
12. Fore body bright green, elytra green, in middle black; anterior elytral spot shorter, less distinctly v-shaped (Fig. 30); aedeagus more sinuate, apex longer, less deflexed ventrally (Fig. 11). New Britain 13. *klapperichii* JEDLICKA
 – Fore body cupreous, elytra black; anterior elytral spot longer, more distinctly v-shaped (Fig. 31); aedeagus less sinuate, apex shorter, more deflexed ventrally (Fig. 12). New Guinea: Biak Island 14. *cuprascens*, sp. n.

13. Large species, c. 10 mm long; tibiae and tarsi contrastingly dark; head and pronotum bright green, elytra black, with basal and apical parts of suture and lateral borders narrowly green; aedeagus markedly sinuate, with elongate, barely curved apex (Fig. 14). Philippine Islands: Luzon 16. *philippinus* HELLER
 - Smaller species, <8.5 mm long; at least tibiae reddish; colour different; aedeagus different 14.
14. Anterior elytral spot narrow, anteriorly deeply excised, distinctly y-shaped, posterior spot transverse, narrow, deeply curved, or markedly serrate (Figs 32, 34, 35) 15.
 - Anterior elytral spot wider and more compact, far less excised, not distinctly y-shaped, posterior spot usually less transverse and narrow, less curved (Figs 27-31) 17.
15. Elytra with distinct green lustre; anterior elytral spot less elongate, posterior spot markedly serrate (Fig. 32); aedeagus remarkably sinuate (Fig. 13). Philippine Islands: Luzon, Negros 15. *undatus* CHAUDOIR
 - Elytra piceous or blackish without green lustre; anterior elytral spot very elongate, posterior spot not markedly serrate (Figs 34, 35); aedeagus less sinuate (Figs 15, 16). Sulawesi (Celebes), New Guinea 16.
16. Head with dense microreticulation and striation, surface rather dull; pronotum with very dense microreticulation and dense transverse wrinkles, surface remarkably dull; elytra in anterior half with 3 setiferous punctures on 3rd and one puncture on 5th interval; microreticulation of elytra rather feeble, surface fairly glossy; aedeagus with big, almost hook-shaped apex (Fig. 15). Sulawesi (Celebes) 17. *picturatus* CHAUDOIR
 - Head with rather feeble microreticulation, striation coarser and less dense, surface rather glossy; pronotum without microreticulation, with few faint, transverse wrinkles, surface highly glossy; elytra in anterior half with 2 setiferous punctures on 3rd interval, none on 5th interval; microreticulation of elytra dense, surface rather dull; aedeagus with less big, gently bent apex (Fig. 16). New Guinea 18. *figuratus* CHAUDOIR
17. Anterior elytral spot short, triangular, anteriorly but slightly incised (Figs 30, 31); microreticulation of elytra superficial, faint, surface fairly glossy. New Guinea, New Britain 18.
 - Anterior elytral spot elongate, about s-shaped, anteriorly well incised (Figs 27-29); microreticulation of elytra dense, distinct, surface rather dull. Malaysia, Sumatra, Borneo 19.
18. Fore body bright green, elytra green, in middle black; anterior elytral spot shorter, less distinctly v-shaped (Fig. 30); aedeagus more sinuate, apex longer, less deflexed ventrally (Fig. 11). New Britain 13. *klapperichi* JEDLICKA
 - Fore body cupreous, elytra black; anterior elytral spot longer, more distinctly v-shaped (Fig. 31); aedeagus less sinuate, apex shorter, more deflexed ventrally (Fig. 12). New Guinea: Biak Island 14. *cuprascens*, sp. n.
19. Pronotum without or with few indistinct transverse wrinkles, anterior sulcus shallow; tarsi not distinctly darker than tibiae; anterior elytral spot shorter, <1.5 × as long as wide (Fig. 27); ♂ genital ring at apex widened; aedeagus without crest on upper surface, surface not markedly rasp-like (Fig. 8). Sumatra, Borneo 10. *xanthopus* SCHAUM
 - Pronotum with dense transverse wrinkles, anterior sulcus deep; tarsi distinctly darker than tibiae; anterior elytral spot longer, almost 2 × as long as wide (Figs 28, 29); ♂ genital ring narrow and elongate at apex; aedeagus with distinct crest on upper surface, surface markedly rasp-like (Figs 9, 10). Malaysia, Sumatra, Borneo 20.
20. Larger species, c. 7.5-8.5 mm long; posterior angles of pronotum distinctly divergent; ♂ genital ring wider, apex shorter; aedeagus more sinuate, crest higher (Fig. 9). Malaysia, Sumatra, Borneo 11. *depressus* ANDREWES
 - Smaller species, <6 mm long; posterior angles of pronotum barely divergent; ♂ genital ring narrower, apex longer; aedeagus less sinuate, crest lower (Fig. 10). Malaysia, Borneo 12. *angusticollis*, sp. n.

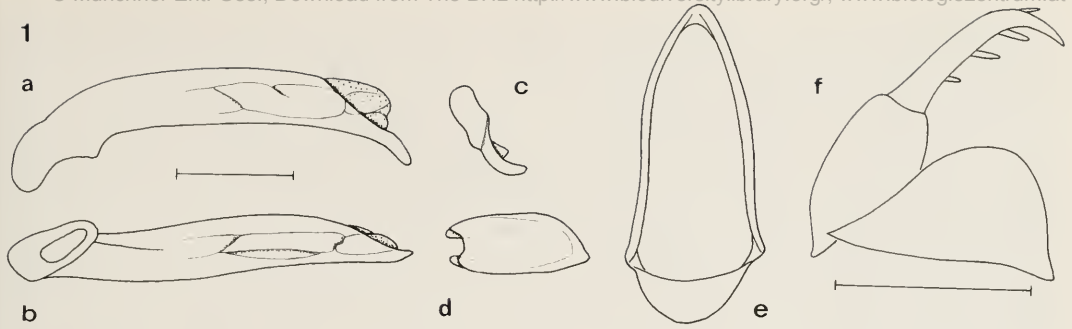

Fig. 1. *Pericalus quadrimaculatus* (MACLEAY). ♂ and ♀ genitalia. a. Aedeagus, lateral view. b. Aedeagus, lower surface. c. Right paramere. d. Left paramere. e. Genital ring. f. ♀ stylomeres and lateral plate. Scale for ♂ genitalia: 0.5 mm, for ♀ genitalia: 0.25 mm.

The species

quadrimaculatus-group

In many respects plesiomorphic group that is defined by the absence of any special characters of external structures and by the simple aedeagus.

This group includes *P. quadrimaculatus* only and is distributed through Malaysia, Thailand, Burma, the Greater Sunda Islands, and Lombok.

1. *Pericalus quadrimaculatus* (MACLEAY)

Figs 1, 17, 18

Catascopus quadrimaculatus MACLEAY, 1825, p. 15.

Coeloprosopus quadrimaculatus, CHAUDOIR 1842, p. 840.

Pericalus quadrimaculatus, CHAUDOIR 1861, p. 123; HELLER 1916, p. 273; ANDREWES 1919, p. 141; CSIKI 1932, p. 1369; JEDLICKA 1953, p. 145; 1963, p. 374; LOUWERENS 1964, p. 187.

Catascopus quadrisignatus CASTELNAU, 1832.

Types (not seen). Not in BMNH.

Type locality. "Java".

Diagnosis. Small to medium-sized species with circular elytral spots, distinguished by small to moderate size of spots and delicate and barely sinuate aedeagus with slightly bent, though not hook-shaped apex.

Description:

Measurements. Length: 5.4-6.9 mm; width: 2.3-2.8 mm. Ratios. Width/length of prothorax: 1.16-1.20; width head/prothorax: 1.32-1.37.

Colour and pattern. Head and prothorax green, sometimes with golden hue. Vertex near eyes sometimes with slight cupreous tinge. Labrum reddish-piceous. Elytra green to slightly blue-green, between spots blackish. Elytral spots yellow to light orange. Antenna reddish-piceous. Legs yellowish, tibiae, tarsi, and apical half of posterior femur piceous, moderately contrasting. Elytra with two rather small to fairly large circular spots of varying size as in figs 17 and 18. Anterior spot usually on 4th-6th intervals, though sometimes overlapping onto 3rd interval or even to 7th interval, posterior spot on 4th-7th intervals, sometimes overlapping onto 3rd interval, rather commonly interrupted in 6th interval.

Head. Surface with very dense and distinct microreticulation. Frons between eyes and vertex with numerous fine, rather regular longitudinal striae. Surface remarkably dull.

Pronotum. Rather narrow, near apex rather convex, prebasal sinuosity fairly deep, posterior angles large, acute, laterally rather projecting. Anterior transverse sulcus shallow, posterior sulcus deep, disk markedly convex. Microreticulation reduced, distinct only laterally and at apex, surface with dense, rather coarse, somewhat irregular transverse wrinkles and fine, rather sparse punctures, fairly glossy.

Elytra. Rather wide, moderately depressed, in ♀♀ apically markedly widened and in anterior third distinctly compressed, in ♂♂ lateral border more regularly curved. Both apical spines rather short. Intervals moderately convex, striae fairly deep, smooth. 3rd interval with 3 punctures, both anterior punctures situated in 3rd stria and in anterior third, posterior puncture near 2nd stria in posterior third. Microreticulation distinct, very transverse, surface moderately dull to fairly glossy.

♂ genitalia. Genital ring (Fig. 1e) elongate, rather parallel, apex evenly rounded. Aedeagus comparatively small and delicate, in ventral view barely sinuate, apex not thickened or hook-shaped, in lateral aspect slightly curved down, curvature sometimes faintly angulate. Parameres as in figs 1c-d.

♀ genitalia. See fig. 1f.

Variation. Apart from some sexual variation of shape of elytra, this is a rather variable species due to its wide range. Some variation noted especially in shape and microsculpture of pronotum and in ground colour and size of elytral spots. Apparently, there is also some geographical variation, because all specimens seen from Malaysia and, on the other hand, from Borneo (Sarawak) have large elytral spots and the posterior spot is not interrupted, whereas all examined specimens from Java and Sumatra have smaller spots and the posterior spot is usually partly or completely interrupted at 6th interval. Despite of the large range, the genitalic characters do not show much variation.

Distribution. Malaysia, Burma, Thailand, Sumatra, Borneo, Java, Lombok, ? Celebes. The last record is due to two specimens labelled Celebes, Palopo Palu, and identified as *P. gratus* SCHAUM by S. L. STRANEO. However, they undoubtedly belong to *P. quadrimaculatus* in view of their external and genitalic characters. Because *P. quadrimaculatus* has not been recorded previously from Celebes, there is some reason to believe that the specimens have been mislabelled.

Material examined (135). **Malaysia:** 5♂♂, 5♀♀, Prov. Pahang, Pulau Tioman, Ayer Barang 13, 1.2.1992, leg. SCHILLHAMMER (CBM, NHMW); 2♀♀, Kampong Pasir, 14.8.1974, G. MINOT (NHMB); 1♂, 1♀, Chandanriang, 19.8.1973, G. MINOT (NHMB); 1♀, Negeri Sembilan, 16 km NNE Seremban, 4.2.1994, GRIMM & RACHINSKY (CBM). - **Thailand:** 1♂, 1♀, 28.4.-6.5.1991, Umphang riv., 1000 m, 16°07'N, 99°00'E, Vít KUBAN leg., Thailand '91 "Thanong Thon Chai" D. KRAL & V. KUBAN (NHMB). - **Sumatra:** 1♂, Medan, coll. HAYEK (ZSM); 1♂, Medan (CBM); 1♀, N-Sumatra Sibolangit Brastagi/Medan, leg. SCHÖDL 15.2.1990 (19) (NHMW); 1♂, 2♀♀, N-Sumatra Bukit Lawang, 27.2.1990, leg. SCHILLHAMMER (CBM, NHMW); 1♂, Sumatra-Acan, Louser NP, 30 km NW Kutacana (18), leg. SCHÖDL 23.2.1990 (NHMW); 5♂♂, 1♀, W-Sumatra, Payakumbuh, Harau Valley, 1000 m, 9.-29.10.1991, leg. A. RIEDEL (CBM); 2♀♀, Ober-Lankat Deli, Sumatra M. UDE S., det. *tetrastigma* (MNHB); 1♀, Sumatra, Collect. PLASON, det. *quadrimaculatus* (NHMW); 1♂, W. Sumatra No. 18, VII 1991, det. *quadrimaculatus* (MNHB). - **Java:** 1♂, 1105, Java DE HAAN, *quadrimaculatus* M. Leay (MNHB); 2♀♀, Hist. Coll. 1105 Java DE HAAN, det. *quadrimaculatus* (MNHB); 1♂, Java occident. Sukabumi 2000', 1893 H. FRUHSTORFER, *Pericalus quadrimaculatus* Macl. S. L. STRANEO det. 1957 (FMT); 1♀, Java occident. Sukabumi 2000', 1893 H. FRUHSTORFER, det. *quadrimaculatus* (MNHB); 3♂♂, 3♀♀, Ost-Java, leg. VAN NIIDEK (ZSM); 3♂♂, Oost-Java, Idjen, leg. H. LUCHT (ZSM); 1♂, 1♀, Popoh Zuider-Geb. Oost-Java, *Pericalus 4-maculatus* Macl. det. C. J. LOUWERENS (MHMW); 1♂, Ostjava Tengger-Geb. 4000' FRUHSTORFER S., det. *quadrimaculatus* (MNHB); 1♂, Ostjava FRUHSTORFER S., det. *quadrimaculatus* (MNHB); 1♂, Java, *Pericalus quadrimaculatus* M. L. (MNHB); 5♂♂, 5♀♀, Java (MNHB); 1♀, Java (ZSM). - **Borneo:** 3♂♂, 5♀♀, Sarawak Belaga, 14.-16.3.1990, leg. A. RIEDEL (CBM, SMNS); 2♂♂, 4♀♀, NW-Borneo Sarawak Belaga, 15.III.1990, leg. A. RIEDEL (CBM). - **Sulawesi (Celebes):** 1♂, 1♀, Celebes Palopo Palu 1990, *Pericalus gratus* SCHAUM det. S. L. STRANEO 1992 (CBM). - ? : 1♀, Sunda Ins. Excell. v. STUDDT G. det. *quadrimaculatus* (MNHB); 53♂♂, ♀♀ (most not sexed), TM (?Sumatra) (ZSM); 1♂, 1♀, Collect. PLASON (?Sumatra), det. *quadrimaculatus* (NHMW).

Note. This is the most commonly encountered species throughout its range. Adults are rather similar to *P. lactus* and *P. gratus* from Sulawesi (Celebes) and, on the other hand, also to *P. robustus* from Java and to *P. signatus* from the Philippines. See note under latter species.

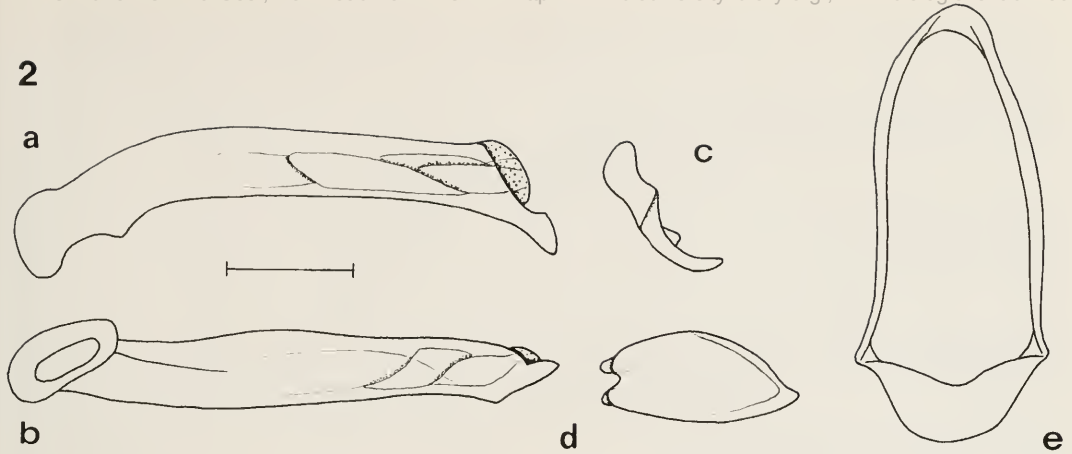

Fig. 2. *Pericalus robustus*, sp. n. ♂ genitalia. For explanations see Fig. 1. Scale: 0.5 mm.

signatus-group

Rather plesiomorphic group that is defined by the absence of any special characters of external structures but is characterized by the edged upper surface of the aedeagus.

This group includes *P. signatus* JEDLICKA and *P. robustus*, sp. n. and is distributed in Java and the Philippine islands Palawan and Samar.

2. *Pericalus robustus*, sp. n.

Figs 2, 19

Types. Holotype: ♂, Java occident. Pengalengam 4000', 1893 (FMT). - Paratype: ♀, Java Boemi Ajoë, *Pericallus 4-signatus*, det. *quadrinaculatus* (MNHB).

Diagnosis. Large species with circular elytral spots, distinguished by small to moderate size of spots, large pronotum with coarse transverse striae, and elongate and barely sinuate aedeagus with slightly bent, in lateral aspect strongly thickened apex.

Description:

Measurements. Length: 8.7-9.1 mm; width: 3.55-3.65 mm. Ratios. Width/length of prothorax: 1.25-1.28; width head/prothorax: 1.28-1.31.

Colour and pattern. Head and prothorax green, sometimes with golden hue. Labrum reddish-piceous. Elytra green, between spots blackish. Elytral spots yellow to light orange. Antenna reddish-piceous. Legs yellowish, tibiae, tarsi, and apical half of posterior femur reddish piceous, not much contrasting. Elytra with two medium-sized circular spots of slightly varying size as in fig. 19. Anterior spot on 4th-5th or 4th-6th intervals, posterior spot on 4th-7th intervals, overlapping onto 3rd interval, in 6th interval completely interrupted or not.

Head. Surface with dense and distinct microreticulation. Frons between eyes and vertex with numerous moderately coarse, somewhat irregular longitudinal striae. Surface moderately dull.

Pronotum. Rather large and wide, near apex rather convex, prebasal sinuosity fairly deep, posterior angles large, acute, laterally rather projecting. Anterior transverse sulcus shallow, posterior sulcus deep, disk markedly convex. Microreticulation reduced, distinct only laterally and at apex, surface with dense, coarse, somewhat irregular transverse wrinkles and rather dense punctures, fairly glossy.

Elytra. Rather wide, moderately depressed; in females apically markedly widened and in anterior third distinctly compressed, in males lateral border more regularly curved. Both apical spines rather short. Intervals moderately convex, striae fairly deep, smooth. 3rd interval with 3 punctures, both anterior punc-

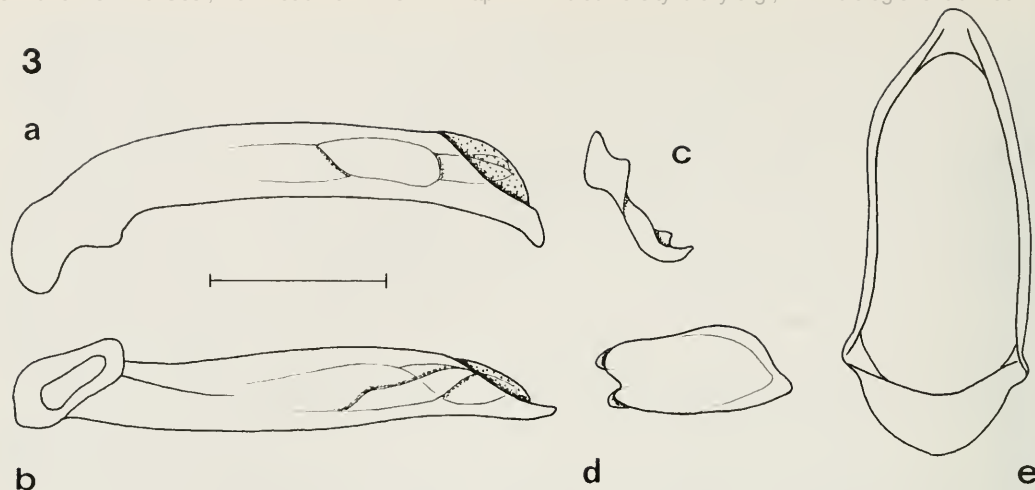

Fig. 3. *Pericalus signatus* JEDLICKA. ♂ genitalia. For explanations see Fig. 1. Scale: 0.5 mm.

tures situated in 3rd stria and in anterior half, posterior puncture near 2nd stria in posterior third. Microreticulation distinct, very transverse, surface fairly glossy.

♂ genitalia. Genital ring (Fig. 2e) elongate, rather parallel, apex evenly rounded. Aedeagus comparatively narrow and elongate, in ventral view barely sinuate, apex markedly thickened, in lateral aspect anteriorly slightly incised, slightly deflected ventrally. Parameres as in figs 2c-d.

♀ genitalia. Very similar to those of *P. quadrimaculatus* (MACLEAY).

Variation. Apart from some sexual variation of shape of elytra, little variation noted due to limited material.

Distribution. Java.

Etymology. The namer refers to the large, robust build of the adults.

3. *Pericalus signatus* JEDLICKA

Figs 3, 20

Pericalus undatus var. *signatus* JEDLICKA, 1936, p. 25.

Pericalus signatus, JEDLICKA 1963, p. 375.

Types (not seen). Types apparently not in BMNH nor in NMNHP.

Type locality. "Palawan", Philippines.

Diagnosis. Small to medium-sized species with circular elytral spots, distinguished by moderate size of spots, coppery colour of fore body, and slightly sinuate aedeagus with fairly downcurved, thickened, though not hook-shaped apex.

Description:

Measurements. Length: 5.8-6.8 mm; width: 2.3-2.9 mm. Ratios. Width/length of prothorax: 1.22-1.25; width head/prothorax: 1.30-1.33.

Colour and pattern. Head and prothorax green with distinct cupreous tinge, or almost completely cupreous. Labrum reddish-piceous. Elytra blackish-green, at base cupreous. Elytral spots yellow to light orange. Antenna reddish. Legs yellowish, tibiae barely darker than femora. Elytra with two fairly large circular spots as in fig. 20. Anterior spot usually on 3rd-5th intervals, commonly overlapping to the 6th

Head. Surface with dense and distinct microreticulation. Frons between eyes and vertex with numerous moderately coarse longitudinal striae. Surface rather dull.

Pronotum. Fairly wide, near apex rather convex, prebasal sinuosity deep, posterior angles large, acute, laterally rather projecting. Anterior transverse sulcus shallow, posterior sulcus deep, disk convex. Microreticulation reduced, distinct only laterally and at apex, surface with dense, very coarse, somewhat irregular transverse wrinkles and fine, rather sparse punctures, fairly glossy.

Elytra. Rather wide, moderately depressed; in females apically markedly widened and in anterior third distinctly compressed, in males lateral border more regularly curved. Both apical spines rather short. Intervals moderately convex, striae fairly deep, smooth. 3rd interval with 3 punctures, both anterior punctures situated in 3rd stria and in anterior half, posterior puncture near 2nd stria in posterior third. Microreticulation distinct, though slightly superficial, very transverse, surface fairly glossy.

♂ genitalia. Genital (Fig. 3e) ring elongate, rather parallel, apex in lateral aspect evenly rounded. Aedeagus comparatively small and delicate, in ventral view slightly sinuate, apex slightly thickened though not hook-shaped, rather deflexed ventrally. Parameres as in figs 3c-d.

♀ genitalia. Very similar to those of *P. quadrimaculatus* (MACLEAY).

Variation. Apart from some sexual variation of shape of elytra, little variation noted, perhaps due to limited material.

Distribution. Philippines: Palawan and Samar.

Material examined (6). **Philippines:** 4♂♂, 2♀♀, N. Palawan Binaluan Nov.-Dez. 1913, leg. G. BOETTCHER, det. *quadrimaculatus* (CBM, MNHB).

laetus-group

This group is defined by the rather sinuate shape of the aedeagus. It is originally plesiomorphic in most respects of external structure but can be subdivided in two subgroups of slightly different phylogenetic states.

The group includes the *laetus*- and *gratus*-subgroups and occurs on Sulawesi (Celebes) and perhaps on eastern Borneo.

laetus-subgroup

This is in many respects the more plesiomorphic subgroup of the *laetus*-group that is defined by the general absence of striking apomorphic features in external structure as well as in structure of the aedeagus.

The subgroup includes only *P. laetus* SCHAUM that occurs on Sulawesi (Celebes) and probably in southern Borneo.

4. *Pericalus laetus* SCHAUM

Figs 4, 21

Pericalus laetus SCHAUM, 1860, p. 190; HELLER 1916, p. 273; ANDREWES 1927, p. 108; CSIKI 1932, p. 1369; LOUWERENS 1964, p. 187.

Pericalus adonis SCHAUFUSS, 1887, p. 104; ANDREWES 1927, p. 109; CSIKI 1932, p. 1369.

Types. Of *laetus*. Lectotype (by present designation): ♀, Makian SCHAUM, 41742, *laetus* SCHAUM* = *adonis* SCHAUF.* (MNHB).

Of *adonis*. Holotype: ♂, *Pericalus Adonis* SCHAUF. Bonthain, *Pericalus* n. sp. (*gratus* aff.) S. Celebes (underside of label) (MNHB).

Type localities. Of *laetus* (from label): "Makian", Sulawesi (Celebes); no locality in description. - Of *adonis*: "Bontain, S. Celebes" (from label); no locality in description.

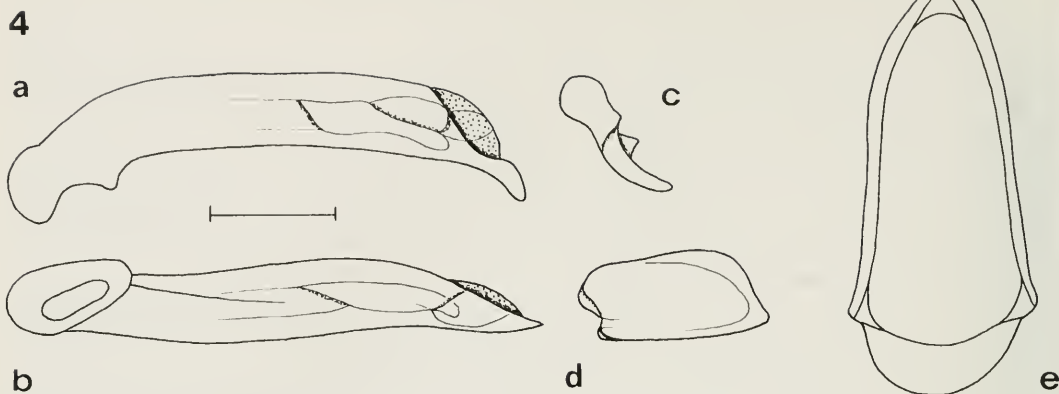

Fig. 4. *Pericalus laetus* SCHAUM. ♂ genitalia. For explanations see Fig. 1. Scale: 0.5 mm.

Diagnosis. Rather large species with moderately large, circular elytral spots, distinguished by rather wide elytra and sinuate ♂ aedeagus with evenly deflexed ventrally apex.

Description:

Measurements. Length: 8.1-9.2 mm; width: 3.45-3.8 mm. Ratios. Width/length of prothorax: 1.26-1.29; width head/prothorax: 1.26-1.28.

Colour and pattern. Head and pronotum green, with or without golden reflexions. Labrum reddish-piceous. Elytra green with more or less extended blackish areas between spots, base with or without golden reflexions. Elytral spots yellow to light orange. Antenna light piceous. Legs dark reddish, tibiae, tarsi, and apical part of posterior femur piceous, though not very contrasting. Elytra with two moderately large circular spots as in fig. 21. Anterior spot on 4th-6th intervals, posterior spot on 4th-7th intervals, though overlapping onto 3rd interval, posteriorly incised on 6th interval.

Head. Surface with very dense and rather coarse microreticulation. Medially of eyes with several fine longitudinal striae. Surface remarkably dull.

Pronotum. Wide, near apex rather convex, prebasal sinuosity fairly deep, posterior angles large, acute, though only moderately or even feebly projecting. Anterior transverse sulcus shallow, posterior sulcus deep, disk markedly convex. Surface densely and coarsely microreticulate, with dense, coarse, somewhat irregular transverse wrinkles, very dull.

Elytra. Wide, moderately depressed, in ♀♀ apically markedly widened and lateral border in anterior third distinctly compressed, in both ♂♂ elytra less wide and less compressed. Lateral apical spine rather short, median spine fairly elongate. Intervals moderately convex, striae fairly deep, smooth. 3rd interval with 3 punctures, both anterior punctures situated in 3rd stria and in anterior third, posterior puncture near 2nd stria in posterior third. Microreticulation distinct, very transverse, surface moderately dull to fairly glossy.

♂ genitalia. Genital (Fig. 4e) ring elongate, rather parallel, apex in lateral aspect evenly rounded. Aedeagus large, in ventral view rather sinuate, apex not thickened, almost evenly deflexed ventrally. Parameres as in figs 4c-d.

♀ genitalia. Very similar to those of *P. quadrimaculatus* (MACLEAY).

Variation. Apparently some sexual variation present, because in ♀♀ the posterior part of elytra is remarkably ampliate and there is a distinct sinuosity in the anterior third of elytra. Shape of pronotum varies also to some degree, because in the holotype of *adonis* (unique specimen!) the posterior angles of the pronotum are less acute and projecting than in the other specimens.

Distribution. Sulawesi (Celebes) and southern Borneo.

Additional material examined (7). **Borneo:** 1♀, Südborneo Bandjermasin L. W. SCHAUFUSS G. (MNHB). - **Sulawesi (Celebes):** 1♂, 3♀, Sulawesi, Donggala - Bez. Kamaroro, Lore Lindu NP, 13.-18.4.1994, leg.

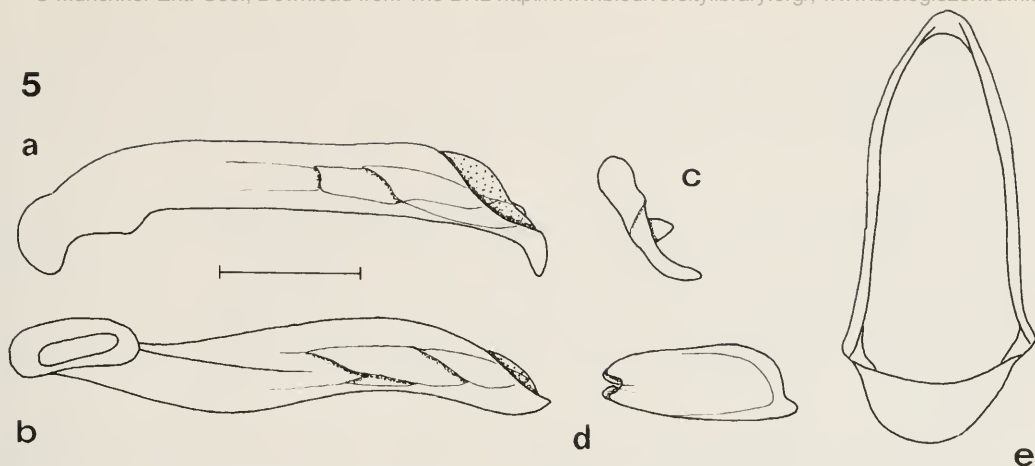

Fig. 5. *Pericalus gratus* SCHAUM. ♂ genitalia. For explanations see Fig. 1. Scale: 0.5 mm.

M. HIERMEIER (CBM, ZSM); 1♀, C-Sulawesi, Palu, Palolo, Lindy NP, 25.-27.8.1990, leg. A. RIEDEL (CBM).

Note. Adults of this species are rather similar to *P. magnus* and *P. gratus*. See note under latter species.

gratus-subgroup

This subgroup is defined by the particularly sinuate shape and the markedly deflexed apex of the aedeagus. In external characters, however, it is still rather plesiomorphic.

The subgroup includes *P. gratus* SCHAUM and *P. magnus*, sp. n. and occurs only on Sulawesi (Celebes).

5. *Pericalus gratus* SCHAUM

Figs 5, 22

Pericalus gratus SCHAUM, 1861, p. 124; SCHAUFUSS 1887, p. 105; ANDREWES 1927, p. 108; CSIKI 1932, p. 1369; LOUWERENS 1964, p. 187.

Types. Lectotype (by present designation): ♂, Type, Hist. Coll. 41741 Celebes Coll. SCHAUM, *gratus* SCHAUM* (MNHB). - Paralectotype: 1♂, same data (MNHB).

Type locality: "Menado, Celebes".

Diagnosis. Rather small to medium-sized species with circular elytral spots, distinguished by small to moderate size of spots and very sinuate aedeagus with suddenly turned down, hook-shaped apex.

Description:

Measurements. Length: 6.3-7.5 mm; width: 2.6-3.15 mm. Ratios. Width/length of prothorax: 1.20-1.24; width head/prothorax: 1.29-1.30.

Colour and pattern. Head and pronotum green, vertex with more or less extended cupreous reflexions. Labrum reddish-piceous. Elytra green, with blackish areas between the spots, base with more or less distinct golden reflexions. Elytral spots yellow to light orange. Antenna reddish-piceous. Legs dark yellow, tibiae and tarsi piceous. Elytra with two rather small, circular or elongate spots of varying size as in fig. 22. Anterior spot on 4th-5th or 4th-6th intervals, posterior spots on 4th-5th or 4th-7th intervals, in latter case usually partly or completely interrupted on 6th interval.

Head. Surface with dense and rather coarse microreticulation. Medially of eyes with several fine longitudinal striae. Surface dull.

Pronotum. Moderately wide. Lateral border near apex rather curved, prebasal sinuosity moderately deep, posterior angles large, acute, laterally moderately projecting. Anterior transverse sulcus very shallow, posterior sulcus deep. Microreticulation of surface rather indistinct and superficial, surface with some puncturation and a fairly dense network of irregular wrinkles, surface moderately dull, posteriorly even fairly glossy.

Elytra. Moderately convex. In ♂ rather narrow, laterally evenly curved; in females fairly wide, posteriorly markedly widened, in anterior third somewhat compressed. Both apical spines rather short. Intervals fairly convex, striae rather deep, smooth. 3rd interval with 3 punctures, both anterior punctures situated in 3rd stria and in anterior third, posterior puncture near 2nd stria in posterior third. Microreticulation superficial, though distinct, transverse, intervals sparsely punctate, surface fairly glossy.

♂ genitalia. Genital (Fig. 5e) ring elongate, rather parallel, apex evenly rounded. Aedeagus rather large, in ventral view markedly sinuate, apex in lateral view deflexed ventrally, hook-shaped. Parameres as in figs 5c-d.

♀ genitalia. Very similar to those of *P. quadrimaculatus* (MACLEAY).

Variation. Some sexual variation noted, as the elytra of the ♀♀ are remarkably wider, posteriorly widened, and anteriorly somewhat compressed. Elytral pattern is also variable, very reduced in both types, though quite variable in a series of specimens from the same locality.

Distribution. Sulawesi (Celebes).

Additional material examined (13). **Sulawesi (Celebes):** 1♂, S. Celebes, Bontain C. RIBBE 1882 (MNHB); 3♂♂, 1♀, C-Sulawesi, Palu, Palolo, Lindy NP, 25.-27.8.1990, leg. A. RIEDEL (CBM); 2♂♂, 3♀♀, S-Sulawesi, 15 km w. Palopo, 11.-19.8.1990, leg. A. RIEDEL (CBM); 1♂, 2♀♀, Sulawesi, 15 km w. Palopo, 18.-19.8.1990, leg. A. RIEDEL (CBM).

Note. Adults of this species are rather similar to both, *P. laetus* and *P. magnus*, but also to *P. quadrimaculatus*. Actually, certain specimens are only distinguished from *quadrimaculatus* by their somewhat different aedeagi.

6. *Pericalus magnus*, sp. n.

Figs 6, 23

Types. Holotype: ♂, S-Sulawesi, 15 km w. Palopo, 11.-19.8.1990, leg. A. RIEDEL (ZSM-CBM). - Paratypes: 2♀♀, C-Sulawesi, Palu, Palolo, Lindy NP, 25.-27.8.1990, leg. A. RIEDEL (CBM).

Diagnosis. Large species with two circular elytral spots, easily recognizable by large size, depressed intervals and shallow striae at least in middle, and strongly sinuate aedeagus with apex sharply deflected ventrally in lateral aspect.

Description:

Measurements. Length: 10.3-10.4 mm; width: 4.2-4.5 mm. Ratios. Width/length of prothorax: 1.29-1.31; width head/prothorax: 1.23-1.25.

Colour and pattern. Head and prothorax green, with or without faint golden tinge. Labrum reddish-piceous. Elytra uniformly green with feeble golden reflexions near base, or greenish-cupreous. Elytral spots light orange. Antenna and palpi light piceous, basal segment of palpi reddish-piceous. Legs light reddish, tibiae and tarsi piceous, little contrasting. Elytral spots circular, anterior spot on 4th-6th intervals, posterior spots on 4th-6th or 4th-7th intervals, slightly overlapping onto 3rd interval, on 6th interval posteriorly excised, as in fig. 23.

Head. Rather large, eyes large, semicircular, frons and vertex depressed. Surface with dense and distinct microreticulation. Frons between eyes and vertex with numerous fine to moderately coarse, rather regular longitudinal striae. Surface rather dull.

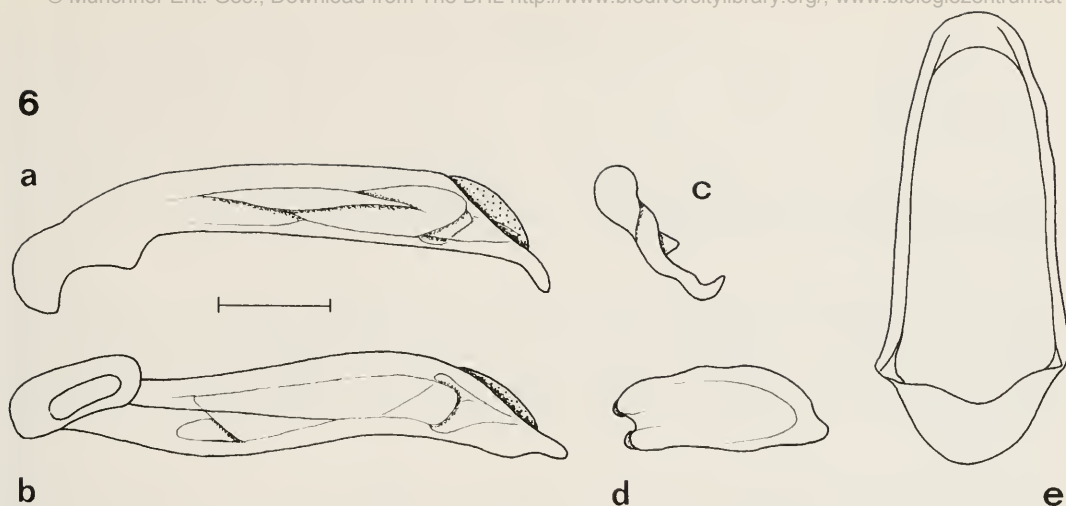

Fig. 6. *Pericalus magnus*, sp. n. ♂ genitalia. For explanations see Fig. 1. Scale: 0.5 mm.

Pronotum. Wide, near apex fairly convex, prebasal sinuosity rather shallow. Anterior angles slightly produced, posterior angles large, acute, laterally moderately projecting. Anterior transversal sulcus shallow, posterior sulcus deep. Microreticulation reduced, distinct only at apex and near lateral borders. Surface with moderately dense, rather fine, somewhat irregular transverse wrinkles and fairly sparse, fine punctures, fairly glossy.

Elytra. Rather wide, moderately depressed; in females apically remarkably widened, in anterior third feebly compressed, in the single male posteriorly slightly widened, laterally more regularly curved. Both apical spines moderately elongate. Intervals moderately convex only at base and near apex, in middle almost depressed. Striae shallow throughout, in middle remarkably fine, smooth. 3rd interval with 3 punctures, both anterior punctures situated in 3rd stria and in anterior third, posterior puncture near 2nd stria in posterior third. Microreticulation transverse, though superficial and rather indistinct, surface glossy.

♂ genitalia. Genital (Fig. 6e) ring elongate, rather parallel, apex evenly rounded. Aedeagus large, in ventral view markedly sinuate, apex in lateral aspect sharply deflected ventrally, rather hook-shaped. Parameres as in figs 6c-d.

♀ genitalia. Very similar to those of *P. quadrimaculatus* (MACLEAY).

Variation. Rather distinct sexual variation in shape of elytra, and also some variation in colouration noted.

Distribution. Sulawesi (Celebes).

Etymology. The name refers to the large size of the adults.

tetrastigma-subgroup

This subgroup is defined by certain extremely plesiomorphic external features, namely the sombre blue-metallic colour and the black legs that recall the colouration in the nominate subgenus *Pericalus* s. str. It is characterized by the presence of setose elytral epipleura.

The subgroup includes *P. tetrastigma* CHAUDOIR and *P. atricornis*, sp. n. and occurs in Malaysia, Sumatra, and Borneo.

7. *Pericalus tetrastigma* CHAUDOIR

Figs 7, 24

Pericalus tetrastigma CHAUDOIR, 1861, p. 123; CSIKI 1932, p. 1369, JEDLICKA 1963, p. 374; LOUWERENS 1964, p. 187.

Types. Lectotype (by present designation): ♀, Ex Musaeo CHAUDOIR, *tetrastigma*, Borneo STEVENS, Muséum Paris 1952 Coll R OBERTHÜR (MNHN). - Paralectotype: ♀, Singapor., Ex Musaeo CHAUDOIR, Muséum Paris 1952 Coll R OBERTHÜR (MNHN).

Note. The series received from the MNHN, Paris, includes a third specimen from the CHAUDOIR Collection without locality label that cannot belong to the type series and therefore serve as a paralectotype, because the description says "Bei Singapor? und Sarrawack von WALLACE entdeckt. Ich besitze zwei Stück dieser niedlichen . . . Art". Although the lectotype has been collected by Stevens according to the label, whereas the description states that it was collected by WALLACE, I think that it nevertheless belongs to the type series.

Type localities: "Sarrawack", north Borneo, and "Singapor", Malaysia.

Diagnosis. Medium-sized to fairly large, rather slender species with circular elytral spots, distinguished by small size of spots, bluish colour of elytra, completely black legs, a row of elongate hairs on epipleura of elytra, and elongate, rather sinuate aedeagus with markedly ventrally deflexed apex. Further distinguished from the closely related *P. atricornis*, sp. n. by narrower, less microsculptured pronotum, and deeper elytral striae.

Description:

Measurements. Length: 7.5-8.5 mm; width: 3.05-3.25 mm. Ratios. Width/length of prothorax: 1.08-1.12; width head/prothorax: 1.34-1.37.

Colour and pattern. Head and prothorax greenish or blue-green. Labrum piceous-black. Elytra blue-green, blue, or blue-violaceous. Elytral spots yellow to light orange. Antenna more or less dark piceous. Legs uniformly dark piceous to black. Elytra with two small circular spots as in fig. 24. Anterior spot in most specimens on 4th-5th intervals, though overlapping onto 6th interval in single specimens, posterior spot on 4th-5th intervals, overlapping or not onto 6th, rarely also onto 3rd interval.

Head. Surface with very dense and distinct microreticulation. Frons between eyes and vertex with numerous fine longitudinal striae. Surface dull.

Pronotum. Narrow, near apex rather convex, prebasal sinuosity deep, posterior angles elongate, acute, laterally rather projecting. Anterior transverse sulcus extremely shallow, posterior sulcus deep, disk markedly convex. Base deeply excised. Microreticulation reduced, distinct only laterally and at apex, surface with dense, fine puncturation and more or less distinct, somewhat irregular transverse wrinkles, rather glossy.

Elytra. Rather narrow, moderately depressed; in females apically slightly widened and in anterior third faintly compressed, in males lateral border regularly curved. Both apical spines short. Epipleura with a row of conspicuous, elongate hairs. Intervals moderately convex, striae fairly deep, smooth. 3rd interval with 3 punctures, both anterior punctures situated in 3rd stria and in anterior third, posterior puncture near 2nd stria in posterior third. Microreticulation distinct, very transverse, surface moderately dull.

♂ genitalia. Genital (Fig. 7e) ring elongate, rather parallel, left arm sinuate, apex evenly rounded. Aedeagus comparatively elongate, in ventral view rather sinuate, apex elongate, in lateral aspect sharply deflexed ventrally, though not thickened or hook-shaped. Parameres as in figs 7c-d.

♀ genitalia. Very similar to those of *P. quadrimaculatus* (MACLEAY).

Variation. Apart from some sexual variation of shape of elytra, little variation noted. This is a rather homogeneous species recognized at the first glance.

Distribution. Malaysia, Sumatra, Borneo. Apart from the lectotype I saw no material from the latter Island.

Additional material examined (24). **Malaysia:** 1♂, 1♀, Perak Malacca (DOHERTY) (BMNH); 2♂, 3♀♀, Perak Malacca, *Pericalus tetrastigma* Chd. S. L. STRANEO det. 1957 (FMT); 1♂, Perak, NEVINSON Coll.

7

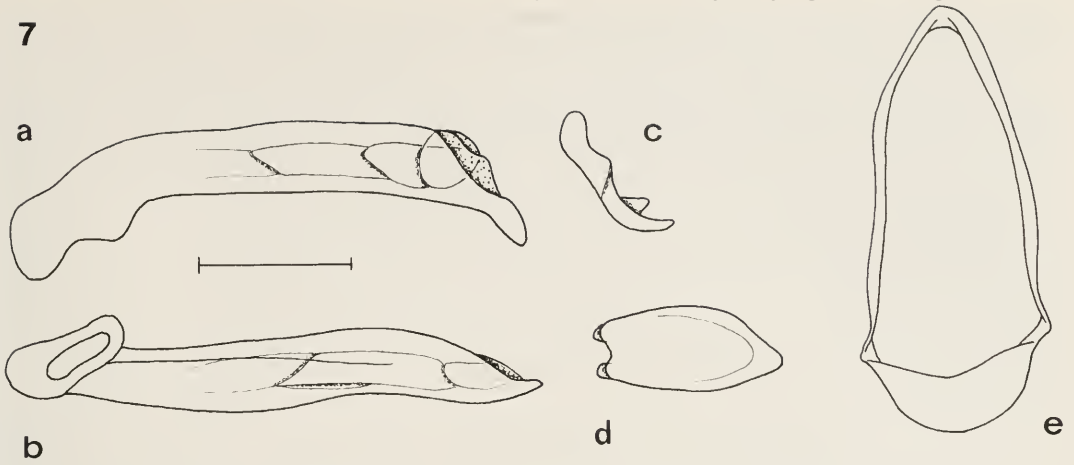

Fig. 7. *Pericalus tetrastigma* CHAUDOIR. ♂ genitalia. For explanations see Fig. 1. Scale: 0.5 mm.

1918-14, Ex coll. Brit. Mus. (BMNH); 1♀, DOHERTY, Perak L. G., Ex coll. Brit. Mus., *Pericalus tetrastigma* CHAUDOIR H. E. ANDREWES det. (BMNH); 1♀, DOHERTY, Perak (BMNH); 1♂, Singap., Probably *Pericallus tetrastigma* (BMNH); 1♀, Singapore, *Pericalus tetrastigma* CHAUDOIR H. E. ANDREWES det. (BMNH); 2♂♂, Singapore 77.15.K (BMNH); 1♂, 41740, Singapore Coll. SCHAUM, *tetrastigma* CHAUD. (MNHB); 1♂, Hist. Coll. 41740 Singapore Coll. SCHAUM, det. *tetrastigma* (MNHB); 1♀, Malacca KÖCHLIN, det. *tetrastigma* (MNHB). - **Sumatra**: 1♂, DOHRN Sumatra Soekaranda, *Pericalus tetrastigma* ANDR. H. E. ANDREWES det. (BMNH); 1♂, Ober-Langkat Deli, Sumatra 1894 M. UDE S.93250, det. *tetrastigma* (MNHB); 1♂, Indonesien Sumatra G. Leuser NP (18), leg. S. SCHÖDL 22./23.2.1990 (NHMW); 1♂, 2♀♀, Sumatra-Acan, Leuser NP, 30 km NW Kutacane (18), leg. SCHÖDL 23.2.1990 (CBM, NHMW). - ? : 1♀, Ex Musaeo CHAUDOIR, Muséum Paris 1952 Coll R OBERTHÜR (MNHN).

8. *Pericalus atricornis*, sp. n.

Fig. 25

Types. Holotype: ♀, SUMATRA (Aceh) KETAMBE Leuser Nat. Park, 450 m, 26.II.-1.III.1991, BOCAK & BOCAKOVA lgt. (NHMB).

Diagnosis. Large species with circular elytral spots, distinguished by rather small size of spots, bluish colour of elytra, completely black legs, completely black antennae, a row of elongate hairs on the epipleura of elytra, and very large, contrastingly black, and conspicuously microreticulate, dull area on vertex. Further distinguished from the closely related *P. tetrastigma* CHAUDOIR by wider, more strongly microsculptured pronotum, and shallower elytral striae.

Description:

Measurements. Length: 10.4 mm; width: 4.05 mm. Ratios. Width/length of prothorax: 1.14; width head/prothorax: 1.32.

Colour and pattern. Head and prothorax dark green, though centre of head widely black. Labrum piceous-black. Elytra blue-violaceous. Elytral spots light orange. Antenna black. Legs uniformly black. Elytra with two small circular spots as in fig. 25. Anterior spot on 4th-5th intervals, overlapping onto median half of 6th interval, posterior spot on 4th-5th intervals, slightly overlapping onto 3rd interval.

Head. Surface with very dense and distinct microreticulation, especially conspicuous in posterior half. Frons between eyes and vertex with numerous fine longitudinal striae. Surface remarkably dull.

Pronotum. Fairly narrow, near apex rather convex, prebasal sinuosity deep, posterior angles elongate, acute, laterally rather projecting. Anterior transverse sulcus extremely shallow, posterior sulcus deep, disk

convex. Base deeply excised. Microreticulation completely reduced, surface with dense, fine puncturation and numerous, rather coarse, somewhat irregular transverse wrinkles, glossy.

Elytra. Moderately wide, rather depressed, in the single female apically distinctly widened and in anterior third faintly compressed. Lateral apical spine short, median spine very short. Epipleuron with a row of conspicuous, elongate hairs. Intervals in middle depressed, striae shallow, smooth. 3rd interval with 3 punctures, both anterior punctures situated in 3rd stria and in anterior half, posterior puncture near 2nd stria in posterior third. Microreticulation distinct, very transverse, surface moderately dull.

♂ genitalia. Unknown.

♀ genitalia. Very similar to those of *P. quadrimaculatus* (MACLEAY).

Variation. Unknown.

Distribution. Sumatra.

Etymology. The name refers to the completely dark antenna.

undatus-group

This group is defined by the large size of the elytral spots, but can be divided in four subgroups of rather different habitus and phylogenetic states.

The group includes the *levifrons*-, *xanthopus*-, *klapperichi*-, and *undatus*-subgroups and occurs in Malaysia, on Sumatra, Borneo, the Philippines, Sulawesi (Celebes), Halmahera (probably), New Guinea, and New Britain.

levifrons-subgroup

This is in some respects of external structure the most plesiomorphic subgroup of the *undatus*-group but it bears some striking apomorphies in the black, non-metallic colour and the absence of microreticulation on the frons. Any statements about ♂ genitalic features are so far not possible, since the male is still unknown.

The subgroup includes only *P. levifrons* HELLER that occurs only on the Philippine island Mindanao.

9. *Pericalus levifrons* HELLER

Fig. 26

Pericallus levifrons HELLER, 1916, p. 273; CSIKI 1932, p. 1369; JEDLICKA 1963, p. 376.

Types. Lectotype (by present designation): ♀, Butuan Mindanao BAKER, 1916 5, *levifrons* Typus (SMTD).

Type locality: "Mindanao: Butuan".

Diagnosis. Rather small, convex species, characterized by two large, about circular elytral spots, black colour of elytra, rather smooth frons, and convex, superficially microreticulate elytral intervals.

Description:

Because the description is good and detailed, only those characters are included that are not mentioned in the description, or that are primarily necessary for species distinction.

Measurements. Length: 7 mm; width: 2.9 mm. Ratios. Width/length of prothorax: 1.23; width head/prothorax: 1.30.

Colour and pattern. Head and prothorax green, labrum reddish-piceous. Elytra black with extremely faint greenish tinge at base. Elytral spots light orange. Antenna reddish. Legs light reddish, tibiae, tarsi, and apical half of posterior leg dark. Elytral spots large, circular to slightly triangular, as in fig. 26. Anterior spot on 4th-8th intervals, slightly overlapping onto 3rd interval, posterior spot on 3rd-8th interval, feebly incised posteriorly on 6th interval.

Head. Clypeus and middle of frons almost devoid of microreticulation, rather sparsely punctate, clypeus somewhat striolate. Vertex moderately microreticulate, barely punctate, lightly striolate, medially of eyes with c. 5 moderate longitudinal striae.

Pronotum. Moderately wide. At apex moderately curved, posteriorly sinuate, posterior angles acute, laterally slightly projecting. Anterior transverse sulcus shallow, posterior sulcus deep. Surface almost devoid of microreticulation, sparsely punctate, with rather dense, though fine transverse wrinkles, fairly glossy.

Elytra. Rather wide, convex, posteriorly distinctly widened, in anterior third barely compressed. Lateral apical spine fairly elongate, medial spine short. Intervals convex throughout, striae deep, smooth. 3rd interval with 3 punctures, both anterior punctures situated in 3rd stria and in anterior half, posterior puncture near 2nd stria in posterior third. Microreticulation superficial, though distinct, strongly transverse. Intervals with scattered sparse punctures, surface glossy.

♂ genitalia. Unknown.

♀ genitalia. Very similar to those of *P. quadrimaculatus* (MACLEAY).

Variation. Unknown.

Distribution. Mindanao, Philippine Islands, apparently known only from type locality.

xanthopus-subgroup

This subgroup is defined by the slightly s-shaped anterior elytral spot and the fairly hook-shaped apex of the aedeagus. It is a well defined subgroup that is related to the *klapperichi*- and *undatus*-subgroups by the elongate shape of the anterior elytral spot.

The subgroup includes *P. xanthopus* SCHAUM, *P. depressus* ANDREWES, and *P. angusticollis*, sp. n., though both latter species are much more closely related one to another, than either to *P. xanthopus*. The subgroup occurs in Malaysia, Sumatra, and Borneo.

10. *Pericalus xanthopus* SCHAUM

Figs 8, 27

Pericalus xanthopus SCHAUM, 1860, p. 191; ANDREWES 1926, p. 286, 287; 1927, p. 108; CSIKI 1932, p. 1369; JEDLICKA 1963, p. 375.

Types. Lectotype (by present designation): ♀(?), 41743, Type, Borneo Coll. SCHAUM, *xanthopus* SCHAUM* (MNHB). - Paralectotype: 1♂, Hist. Coll. 41743 Borneo Coll. SCHAUM (MNHB).

Type locality: "Borneo".

Diagnosis. Rather small species with elongate, though not markedly y-shaped anterior elytral stripe, distinguished from related species by pattern, dull, iridescent surface of elytra, feebly sinuate aedeagus with sharply hook-shaped apex, and apically wide ♂ genital ring. From the closely related species *P. depressus* ANDREWES and *P. angusticollis*, sp. n. further distinguished by shorter anterior elytral stripe, shallow anterior transverse sulcus of pronotum, far less strongly transversely wrinkled surface of pronotum, and absence of crest on upper surface of aedeagus.

Description:

Measurements. Length: 5.8-6.5 mm; width: 2.4-2.7 mm. Ratios. Width/length of prothorax: 1.26-1.29; width head/prothorax: 1.27-1.32.

Colour and pattern. Head and pronotum green, with or without golden reflexions, pronotum even completely golden-green. Labrum reddish. Palpi and basal segments of antenna reddish, rest darker. Elytra green, space between and around elytral spots blackish, or only border, apex, base, and suture of elytra green. Elytral spots orange. Legs yellow, tibiae and tarsi but feebly darker. Elytral spots large and wide, indistinctly y-shaped as in fig. 27. Anterior spot wide, shorter than in related species, on 4th-8th intervals, though slightly overlapping onto 3rd interval, by far longest on 4th-6th intervals. Posterior spot

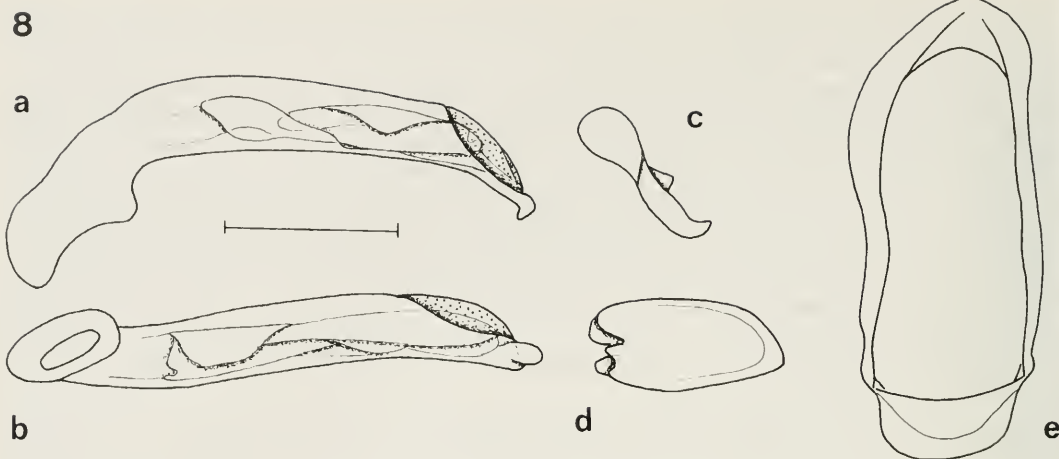

Fig. 8. *Pericalus xanthopus* SCHAUM. ♂ genitalia. For explanations see Fig. 1. Scale: 0.5 mm.

shorter, on 4th-7th intervals, in most specimens occupying also the external half of 3rd interval, slightly incised posteriorly on 6th interval.

Head. Moderately wide, though eyes very large. Frons between eyes and vertex slightly convex. Microreticulation rather superficial. Surface with sparse irregularly longitudinal, very coarse striae and some puncturation, rather uneven. Medially of eyes with 3-4 remarkably strong longitudinal grooves. Surface rather glossy.

Pronotum. Moderately wide, rather convex. Lateral border near apex convex, prebasal sinuosity rather deep, posterior angles large, acute, somewhat projecting. Anterior transversal sulcus shallow, posterior sulcus deep. Microreticulation reduced, visible only at apex and near lateral borders. Surface with more or less sparse, irregular transverse wrinkles and some scattered puncturation, glossy.

Elytra. Moderately convex, rather wide in both sexes, even in males posteriorly widened and at anterior third slightly compressed. Lateral apical spine short, median spine very short. Intervals fairly convex, striae deep, smooth. 3rd interval with 3 punctures, both anterior punctures situated in 3rd stria and in anterior half, posterior puncture near 2nd stria in posterior third. Microreticulation very distinct, consisting of extremely transverse meshes and lines. Surface also with scattered minute punctures, dull, though highly iridescent.

♂ genitalia. Genital (Fig. 8e) ring elongate, rather parallel, apex remarkably wide, basal plate laterally markedly constricted. Aedeagus rather large, in ventral view moderately sinuate, apex in lateral aspect characteristically hook-shaped. Parameres as in figs 8c-d.

♀ genitalia. Very similar to those of *P. quadrimaculatus* (MACLEAY).

Variation. Apart from some sexual variation of shape of elytra only some variation of degree of microsculpture on head and pronotum noted.

Distribution. Sumatra, Borneo, ? Sulawesi (Celebes). The latter record is doubtful, because WALLACE's locality records, especially those referring to Celebes, are rather uncertain.

Additional material examined (11). **Sumatra:** 1 ♀, N-Sumatra Sibolangit Brastagi/Medan, leg. SCHÖDL 15.2.1990 (19) (NHMW). - **Borneo:** 1 ♂, Sarawak, Belaga, 14.-16.3.1990, leg. A. RIEDEL (CBM); 1 ♀, Sarawak, Belaga-Distr. 5 km s. Long Lenau, 18.3.1990, leg. A. RIEDEL (CBM); 1 ♀, STEVENS 860, *lactus* SCHM. Borneo (NHMW); 1 ♀, Mal. Sarawak 1993, Kelabit HL, 6 km E Bario, Pa Ukat, 1.3., c. 1000 m, leg. M. JÄCH (17)(NHMW). - **Sulawesi (Celebes):** 4 ♂♂, 1 ♀, Celebes WALLACE (MNHB); 1 ♀, nova sp. Celebes, *figuratus* CHD.? (MNHB).

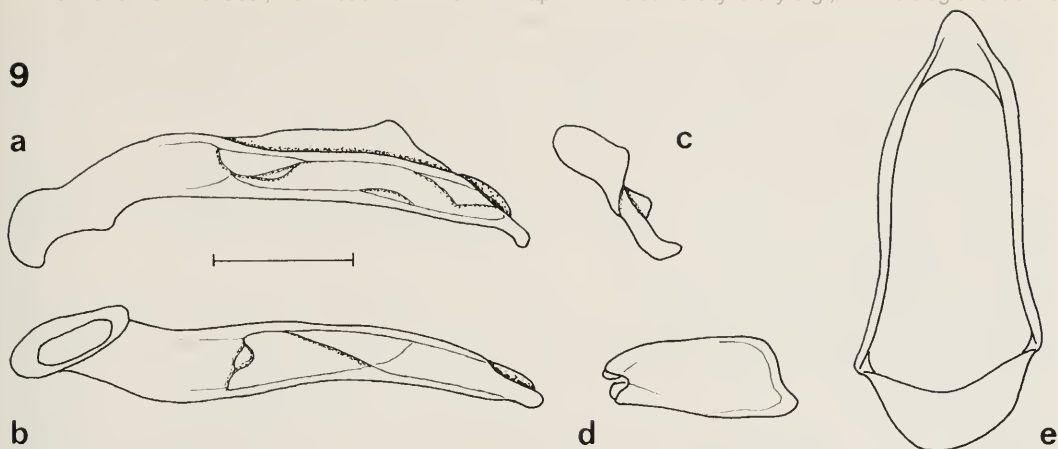

Fig. 9. *Pericalus depressus* ANDREWES. ♂ genitalia. For explanations see Fig. 1. Scale: 0.5 mm.

11. *Pericalus depressus* ANDREWES

Figs 9, 28

Pericalus depressus ANDREWES, 1926, p. 285; CSIKI 1932, p. 1368; LOUWERENS 1964, p. 186.

Types. Holotype (by original designation): ♂, Perak Malacca (DOHERTY), Type, *Pericalus depressus* ANDR. Type H. E. ANDREWES det. (ANDREWES hand) (BMNH). - Paratypes: 2 ♀ ♀, same data, Cotype (BMNH); 2 ♂ ♂, Perak L. C., Ex coll. Brit. Mus., Cotype (BMNH); 1 ♂, Martapura, S. E. Borneo, DOHERTY 1891, SHARP Coll. 1905-313, Ex coll. Brit. Mus., *Pericalus depressus* ANDR. Cotype H. E. ANDREWES det. (ANDREWES hand), Cotype (BMNH); 1 ♀, same data, Cotype (BMNH); 1 ♀, J. B. CORPORAAL, Sumatra's O K, Sibolangit, 19.X.21, 550 M, Cotype (BMNH); 1 ♀, Sumatra, Cotype (BMNH); 1 ♂, Brunei, Borneo, (waterstradh), Ex coll. T. SPENCE, Cotype (BMNH); 1 ♂, Cotype, Sandakan Borneo BAKER, Ex Mus. Coll. Agric. Phil. Is., Cotype (BMNH).

Type locality: "Perak: Malacca" (from description).

Note. In the SCHAUM collection of the MNHB there are two specimens labelled "Type *rugicollis* SCHAUM", that are conspecific with *depressus* ANDREWES. This name seems to have been never published and is nomenclatorially invalid.

Diagnosis. Moderately large species with elongate, though not markedly y-shaped anterior elytral stripe, further characterized by deep anterior transversal sulcus and extremely dense and coarse transverse wrinkles on pronotum, and by dorsally crested aedeagus. Distinguished from the closely related *P. angusticollis*, sp. n. by larger size, wider and posteriorly more widened elytra, larger head compared with pronotum, and more coarsely wrinkled surface and laterally more projecting posterior angles of pronotum.

Description:

Measurements. Length: 7.4-8.5 mm; width: 3.1-3.3 mm. Ratios. Width/length of prothorax: 1.20-1.22; width head/prothorax: 1.32-1.35.

Colour and pattern. Head and pronotum bright green, near eyes and anterior border of clypeus with distinct, at apex of pronotum with more or less distinct cupreous reflexions. Labrum reddish-piceous. Antenna dark piceous, 3-4 basal segments reddish. Palpi light reddish, terminal segment of both palpi contrastingly black, preapical segment piceous. Elytra green or greenish-coppery, base and suture with or without golden reflexions, space between elytral spots blackish. Elytral spots light reddish. Legs yellowish, tarsi contrastingly dark. Elytral stripes not distinctly y-shaped, as in fig. 28. Anterior stripe very elongate,

on 2nd-7th intervals, overlapping onto 8th interval, very short on 6th-7th intervals, posterior stripe on 4th-7th interval, overlapping onto 3rd interval, slightly incised posteriorly at 6th interval.

Head. Wide, eyes very large. Frons and vertex with very dense and coarse, irregular, wavy wrinkles, medially of eyes with c. 3 strong, longitudinal striae. Microreticulation present, though inconspicuous within the very rough surface. Surface moderately dull to moderately glossy.

Pronotum. Moderately wide, surface rather convex. Lateral border near apex rather convex, prebasal sinuosity shallow, posterior angles large, acute, little projecting. Anterior transverse sulcus very deep, posterior sulcus also deep. Surface, apart from area in front of anterior sulcus with dense, very coarse, transverse wrinkles, microreticulation present, though indistinct within the wrinkles. Hence surface very rough, moderately dull to fairly glossy.

Elytra. Wide, moderately depressed, even in males posteriorly distinctly widened and in anterior third slightly compressed. Both apical spines short. Intervals rather convex, striae deep, smooth. 3rd interval with 3 punctures, both anterior punctures situated in 3rd stria and in anterior third, posterior puncture near 2nd stria in posterior third. Microreticulation dense, distinct, very transverse. Surface rather dull, somewhat iridescent.

♂ genitalia. Genital (Fig. 9e) ring elongate, rather parallel, apex tapering, shortly rounded. Aedeagus rather large, narrow, on upper surface with characteristic crest, apex knob-shaped. Surface very strongly napped. Parameres as in figs 9c-d. Apical part of right paramere elongate, unusual for species of *Pericalus*, but of regular shape of carabids.

♀ genitalia. Very similar to those of *P. quadrimaculatus* (MACLEAY).

Variation. Apart from some sexual variation in shape of elytra, relatively large variation noted in following characters: size, colour of pronotum and elytra, and degree of transverse striation of pronotum.

Distribution. Malaysia, Sumatra, Borneo.

Additional material examined (38). **Malaysia:** 1♂, Malacca Perak, det. *rugicollis* (MNHB); 2♀♀, Perak Malacca, det. *picturatus* (FMT), 1♀, Malacca KÖCHLIN, *Pericalus depressus* ANDR. (MNHB); 4♂♂, 6♀♀, Kampong Pasir, 12.8.1974, J. Marc (NHMB); 1♂, 1♀, Kampong Pasir, 14.8.1974, J. MARC (NHMB); 2♀♀, Chendenriang, 19.8.1973, G. MINOT (NHMB); 1♂, W-Malaysia, Selengor W. Kuala Lumpur, Ulu Gombak, 16.2.1993, leg. H. ZETTEL (1) (NHMW). - **Sumatra:** 1♂, Ober-Langkat Deli, Sumatra, 1894, M. UDE S., det. *depressus* (MNHB); 1♂, Ober-Langkat Deli, Sumatra, 1894, W. REINSCH S., 93252, det. *rugicollis* (MNHB); 1♂, W-Sumatra, Payakumbuh, Harau Valley, 1000 m, 9.-29.10.1991, leg. A. RIEDEL (CBM), 1♀, W-Sumatra No. 18, VII.1991, det. *depressus* (MNHB). - **Borneo:** 1♂, 41744, Borneo Coll. SCHAUM, Type, *rugicollis* SCHAUM (MNHB); 1♀, Hist. Coll. 41744 Borneo Coll. SCHAUM, Type, det. *rugicollis* (MNHB); 1♂, 1♀, Sarawak Belaga, 14.-16.3.1990, leg. A. RIEDEL (SMNS); 2♂♂, 7♀♀, NW-Borneo Sarawak Belaga, 15.III.1990, leg. A. RIEDEL (CBM, ZSM). - ? : 1♀, TM (?Sumatra) (ZSM).

12. *Pericalus angusticollis*, sp. n.

Figs 10, 29

Types. Holotype: ♂, Sarawak, Belaga, 14.-16.3.1990, leg. A. RIEDEL (ZSM-CBM). - Paratype: 1♀, Malaysia G. MINOT, Chendenriang 19.VIII.73 (NHMB).

Diagnosis. Small species with elongate, not distinctly y-shaped anterior elytral stripe, further characterized by deep anterior transversal sulcus and dense and fairly coarse transverse wrinkles on pronotum, and by dorsally crested aedeagus. Distinguished from the closely related *P. depressus* ANDREWES by smaller size, narrower, posteriorly less widened elytra with evenly curved lateral border, smaller head compared with pronotum, and less coarsely wrinkled surface and laterally not projecting posterior angles of pronotum.

Description:

Measurements. Length: 5.8-5.9 mm; width: 2.2-2.4 mm. Ratios. Width/length of prothorax: 1.20; width head/prothorax: 1.29-1.32.

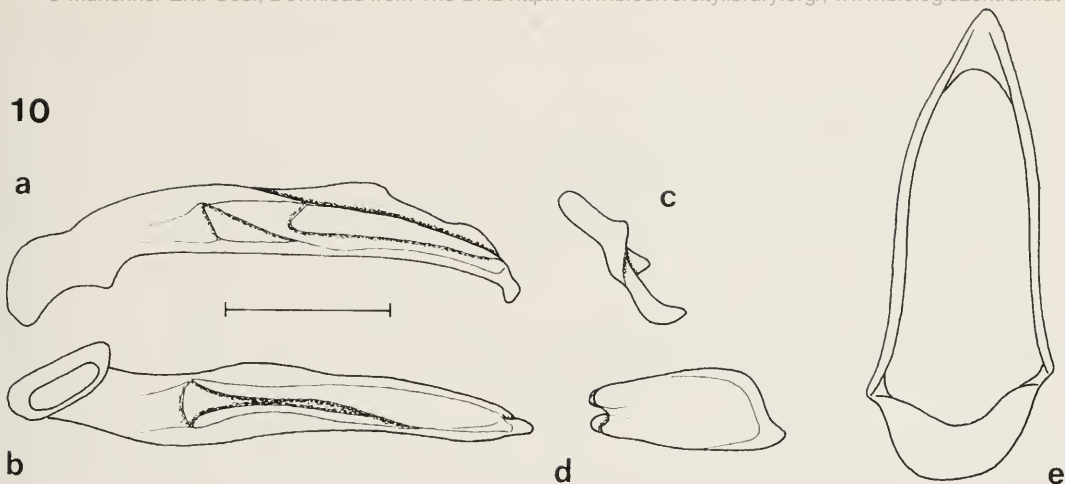

Fig. 10. *Pericalus angusticollis*, sp. n. ♂ genitalia. For explanations see Fig. 1. Scale: 0.5 mm.

Colour and pattern. Head and pronotum bright green, almost devoid of golden reflexions. Labrum reddish-piceous. Antenna dark piceous, 3-4 basal segments reddish. Palpi light reddish, terminal segment of both palpi contrastingly black, preapical segment also black. Elytra green, base and suture with some golden reflexions, space between elytral spots and around the spots to shoulders blackish. Elytral stripes light reddish. Legs yellowish, tarsi dark. Elytral stripes not distinctly y-shaped, as in fig. 29. Anterior stripe very elongate, on 2nd-7th intervals, overlapping onto 8th interval, very short on 6th-7th intervals, posterior stripe on 4th-7th interval, overlapping onto 3rd interval, slightly incised posteriorly at 6th interval.

Head. Shape of head and structure of mouth-parts rather similar to those of *P. depressus*. Head rather wide, eyes very large. Frons and vertex with very dense and coarse, irregular, wavy wrinkles, medially of eyes with c. 3 strong, longitudinal striae. Microreticulation present, though very indistinct within the very rough surface. Surface rather glossy.

Pronotum. Moderately narrow, surface rather convex. Lateral border near apex rather convex, prebasal sinuosity very shallow, lateral border near apex almost parallel. Posterior angles large, acute, laterally virtually not projecting. Anterior transverse sulcus very deep, posterior sulcus also deep. Surface, apart from area in front of anterior sulcus with dense, fairly coarse, transverse wrinkles, microreticulation apparently reduced, almost invisible within the wrinkles. Surface rough, fairly glossy.

Elytra. Moderately wide, moderately depressed; in males posteriorly feebly widened, in anterior third not compressed, lateral border evenly curved; in females posteriorly widened and in anterior third slightly compressed. Both apical spines short. Intervals rather convex, striae deep, smooth. 3rd interval with 3 punctures, both anterior punctures situated in 3rd stria and in anterior third, posterior puncture near 2nd stria in posterior third. Microreticulation dense, distinct, very transverse. Surface rather dull, fairly iridescent.

♂ genitalia. Genital ring (Fig. 10e) elongate, rather parallel, apex tapering, shortly rounded. Aedeagus small, narrow in apical half, on upper surface with characteristic crest, apex in lateral aspect knob-shaped. Surface very strongly napped. Parameres as in figs 10c-d. Apical part of right paramere narrow and remarkably elongate, unusual for species of *Pericalus*, but of regular shape of carabids.

♀ genitalia. Very similar to those of *P. quadrimaculatus* (MACLEAY).

Variation. Apart from some sexual variation in shape of elytra, little variation noted due to limited material.

Distribution. Malaysia and Borneo: Sarawak.

Etymology. The name refers to the narrow pronotum.

11

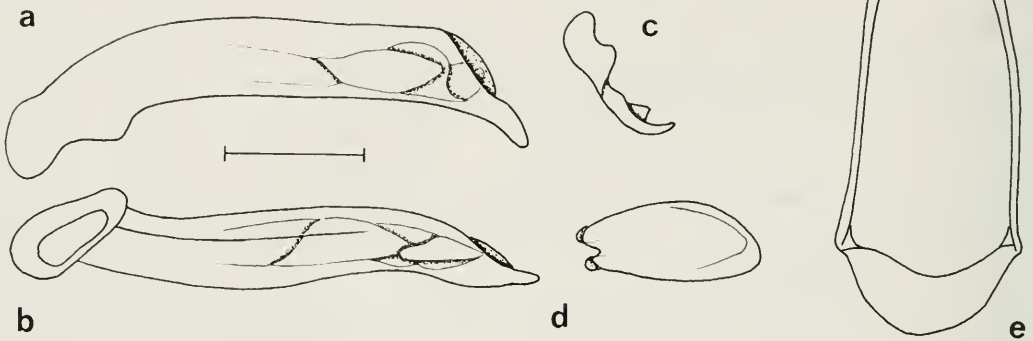

Fig. 11. *Pericalus klapperichi* JEDLICKA. ♂ genitalia. For explanations see Fig. 1. Scale: 0.5 mm.

klapperichi-subgroup

This subgroup is defined mainly by the reduced microreticulation of the elytra. It is related to the *undatus*-subgroup by the y-shaped anterior and the lunate posterior elytral spots, but both character states are less well developed in the *klapperichi*-group than they are in the *undatus*-subgroup.

The subgroup includes *P. klapperichi* JEDLICKA and *P. cuprascens*, sp. n., and occurs on New Britain and on Biak Island near New Guinea.

13. *Pericalus klapperichi* JEDLICKA

Figs 11, 30

Pericalus klapperichi JEDLICKA, 1953, p. 145; 1963, p. 376; LOUWERENS 1964, p. 187; 1969, p. 364; DARLINGTON 1968, p. 110.

Pericalus macrostictus LOUWERENS, 1969, p. 363 (syn. n.).

Types. Of *klapperichi*: Lectotype (by present designation): 1 ♀, Mope, Neupommern, P. Jos. SCHNEIDER leg. 1937 15.III., Cotype, *Klapperichi* sp. n. Det. Ing. JEDLICKA (NMNHP).

Of *macrostictus*: ♂, holotype, ♀ allotype, New Britain: Yalom, 1000 m (not seen).

Type localities. Of *klapperichi*: "Mope, Neupommern bei Neu Guinea", New Britain. - Of *macrostictus*: "Yalom", New Britain.

Note. Even when the types of *P. macrostictus* LOUWERENS were not available for comparison, the description and figure in the original description of this species match exactly the examined lectotype of *klapperichi*. Although the elytral spots are described as "much larger" in *macrostictus* than in *klapperichi*, this is not so judging from the figure, so there is actually no appreciable difference between both species. The author even wrote that *macrostictus* "is perhaps not more than a modified form of *klapperichi*". Furthermore, it seems very unlikely that on New Britain two very closely related species should occur.

Diagnosis. Medium-sized, convex species, characterized by two large elytral spots, the anterior being rather triangular, the posterior about reniform, greenish-black colour of elytra, densely chagreened frons, markedly punctate elytral striae, convex, only superficially microreticulate, glossy intervals, and rather sinuate aedeagus with moderately downcurved apex.

Description:

Measurements. Length: 6.8-7.1 mm; width: 2.85-2.95 mm. Ratios. Width/length of prothorax: 1.22-1.25; width head/prothorax: 1.29-1.34.

Colour and pattern. Head and prothorax green, near eyes with or without slight golden or cupreous tinge, labrum reddish-piceous. Elytra greenish-black, in middle between the spots rather blackish with less greenish tinge. Elytral spots bright yellow. Antenna reddish. Legs light reddish, tibiae and tarsi slightly darker. Anterior elytral spot large, slightly triangular, anteriorly slightly incised, posterior spots rather reniform, posteriorly concave, as in fig. 30. Anterior spot on 4th-8th intervals, slightly overlapping onto 3rd interval, posterior spot on 3rd-8th interval, overlapping at least onto lateral half of 2nd interval.

Head. Clypeus densely striolate, frons and vertex with dense microreticulation, laterally of eyes with several rather fine to fairly coarse, irregular longitudinal striae. Surface dull.

Pronotum. Moderately wide. At apex moderately curved, posteriorly sinuate, posterior angles acute, laterally moderately projecting. Anterior transverse sulcus very shallow and inconspicuous, posterior sulcus deep. Surface with feeble to moderate microreticulation, sparsely punctate, with rather dense, fairly coarse, transverse wrinkles, fairly glossy.

Elytra. Rather short and wide, convex; in males rather evenly curved, though posteriorly distinctly widened; in females anterior third laterally rather compressed. Lateral apical spine fairly elongate, median spine moderately elongate. Intervals moderately convex, striae fairly deep, markedly punctate. 3rd interval with 3 punctures, both anterior punctures situated in 3rd stria and in anterior half, posterior puncture near 2nd stria in posterior third. Microreticulation superficial, though distinct, markedly transverse. Surface glossy.

♂ genitalia. Genital (Fig. 11e) ring elongate, rather parallel, apex evenly rounded. Aedeagus moderately large, in ventral view rather sinuate, apex in lateral aspect slightly deflexed ventrally, barely thickened and not hook-shaped. Parameres as in figs 11c-d.

♀ genitalia. Very similar to those of *P. quadrimaculatus* (MACLEAY).

Variation. Some minor variation noted in degree of microreticulation of head, degree of sculpturation of pronotum, depth of elytral striae, and shape of elytral spots.

Distribution. New Britain.

Additional material examined (3). **New Britain:** 3♂♂, 1221, Neu-Britannien Ralum F. DAHL S. (CBM, MNHB).

14. *Pericalus cuprascens*, sp. n.

Figs 12, 31

Types. Holotype: ♂, Irian Jaya, Biak Isl., Umg. Sepse, 3.10.1990, leg. A. RIEDEL (ZSM-CBM).

Diagnosis. Medium sized species with wide elytral spots, the anterior being triangular, the posterior reniform, distinguished by cupreous fore body, black elytra, strongly, irregularly wrinkled surface of pronotum, and feebly sinuate aedeagus with slightly deflexed apex in lateral view.

Description:

Measurements. Length: 7.3 mm; width: 2.95 mm. Ratios. Width/length of prothorax: 1.27; width head/prothorax: 1.32.

Colour and pattern. Head and pronotum cupreous, only clypeus, middle of frons, and lateral borders of pronotum greenish. Labrum reddish-piceous. Antenna and palpi completely reddish. Elytra black throughout, elytral spots light reddish. Legs completely light reddish. Elytral spots wide, anterior spot triangular, anteriorly excised, posterior spot reniform, as in fig. 31. Anterior spot comparatively short and wide, on 3rd-8th intervals, overlapping onto 2nd interval, abruptly shortened from 5th interval, posterior spot on 2nd-7th interval, narrowly overlapping onto 8th interval, rather reniform.

Head. Wide, eyes very large. Surface covered with many coarse, irregular longitudinal and oblique wrinkles, near eyes with 3 narrow longitudinal striae. Microreticulation present, though indistinct. Surface fairly rough, moderately glossy.

12

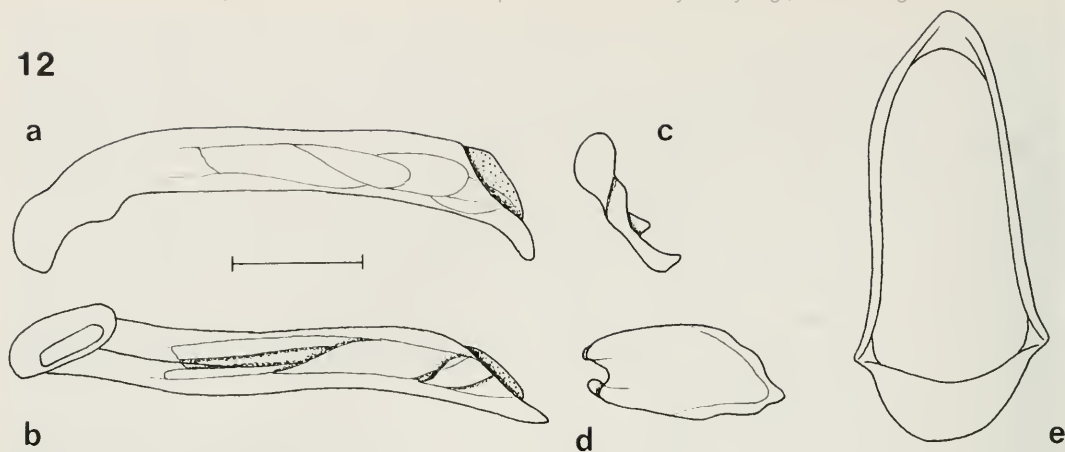

Fig. 12. *Pericalus cuprascens*, sp. n. ♂ genitalia. For explanations see Fig. 1. Scale: 0.5 mm.

Pronotum. Rather wide, moderately depressed. Lateral border near apex convex, prebasal sinuosity rather deep, posterior angles large, acute, laterally rather projecting. Anterior transverse sulcus shallow, posterior sulcus deep. Apart from area in front of anterior sulcus, surface covered by rather dense, coarse, very irregular wrinkles and by scattered, fine punctures. Microreticulation reduced, visible only at apex and near lateral borders. Surface glossy.

Elytra. Rather wide, markedly convex, in the single male posteriorly slightly widened, though in anterior third not compressed, lateral border evenly curved. Both apical spines remarkably elongate. Intervals moderately convex, striae fairly deep, distinctly crenulate. 3rd interval with 3 punctures, both anterior punctures situated in 3rd stria and in anterior third, posterior puncture near 2nd stria in posterior third. Microreticulation very transverse, distinct, though superficial, surface fairly glossy.

♂ genitalia. Genital ring (Fig. 12e) elongate, rather parallel, apex shortly tapering, obtusely rounded. Aedeagus fairly large, in ventral view moderately sinuate, apex acute, in lateral aspect slightly deflexed ventrally. Parameres as in figs 12c-d.

♀ genitalia. Unknown.

Variation. Unknown.

Distribution. Irian Jaya: Biak Island.

Etymology. The name refers to the cupreous colouration of the fore body.

undatus-subgroup

This subgroup is mainly defined by the extremely y-shaped anterior elytral spot and the markedly spinose elytral apices. In several respects it is the most evolved subgroup at all.

The subgroup includes *P. undatus* CHAUDOIR, *P. philippinus* HELLER, *P. picturatus* CHAUDOIR, and *P. figuratus* CHAUDOIR and it occurs in the Philippines, on Sulawesi (Celebes), New Guinea, and probably on Halmahera.

15. *Pericalus undatus* CHAUDOIR

Figs 13, 32

Pericalus undatus CHAUDOIR, 1848, p. 111; 1861, p. 123; HELLER 1916, p. 274; CSIKI 1932, p. 1369; JED-LICKA 1963, p. 375.

13

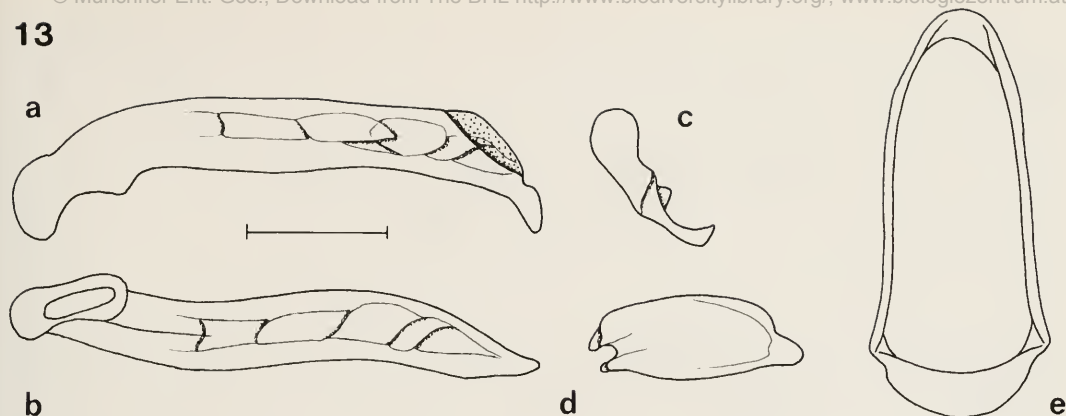

Fig. 13. *Pericalus undatus* CHAUDOIR. ♂ genitalia. For explanations see Fig. 1. Scale: 0.5 mm.

Types. Lectotype (by present designation): ♂, Ex Musaeo CHAUDOIR, *undatus*, Iles Philippines TATUM (MNHN).

Type locality. "Iles Philippines".

Diagnosis. Rather small to fairly large species with wide, markedly serrate elytral stripes, distinguished by bright green fore body, blackish-green elytra, narrow pronotum with very elongate, laterally markedly projecting basal angles and strongly, irregularly wrinkled surface, and markedly sinuate aedeagus with thickened, slightly deflexed apex.

Description:

Measurements. Length: 6.2-8.8 mm; width: 2.5-3.3 mm. Ratios. Width/length of prothorax: 1.11-1.16; width head/prothorax: 1.34-1.42.

Colour and pattern. Head and pronotum bright green, with or without faint golden hue. Labrum reddish-piceous. Elytra green, in middle blackish, elytral spots light reddish. Antenna reddish-piceous with basal segment yellow. Legs yellow, tibiae and tarsi slightly darker, not much contrasting. Elytral spots wide, both spots very serrate, anterior stripe distinctly y-shaped, as in fig. 32. Anterior stripe elongate and wide, on 2nd-8th intervals, very short in 5th-6th intervals, posterior spot on 2nd-7th interval, overlapping or not onto 1st and/or 8th interval, very serrate, prolonged anteriorly on 5th interval and here very close to anterior stripe.

Head. Wide, eyes very large. Surface covered with many fine, irregular longitudinal and oblique strioles, some specimens near eyes with coarser longitudinal strioles. Microreticulation dense and distinct. Surface moderately glossy.

Pronotum. Narrow, moderately depressed. Lateral border near apex convex, prebasal sinuosity deep, posterior angles large, very elongate, acute, postero-laterally strongly projecting. Anterior transverse sulcus shallow, posterior sulcus deep. Apart from area in front of anterior sulcus, surface with rather dense to dense, coarse, irregular wrinkles and with scattered, fine punctures. Microreticulation reduced, visible only at apex and near lateral borders, in few specimens microreticulation more distinct. Surface glossy.

Elytra. Rather wide, markedly convex; in females posteriorly markedly widened and in anterior third compressed, in males lateral border more evenly curved. Both apical spines rather short. Intervals convex, striae deep, almost smooth. 3rd interval with 3 punctures, both anterior punctures situated in 3rd stria and in anterior third, posterior puncture near 2nd stria in posterior third. Microreticulation very transverse, distinct, surface moderately glossy.

♂ genitalia. Genital ring (Fig. 13e) elongate, rather parallel, apex regularly rounded. Aedeagus fairly large, in ventral view markedly sinuate, apex thickened and slightly incised anteriorly, in lateral aspect deflexed. Parameres as in figs 13c-d, left paramere near apex deeply incised.

♀ genitalia. Very similar to those of *P. quadrimaculatus* (MACLEAY).

14

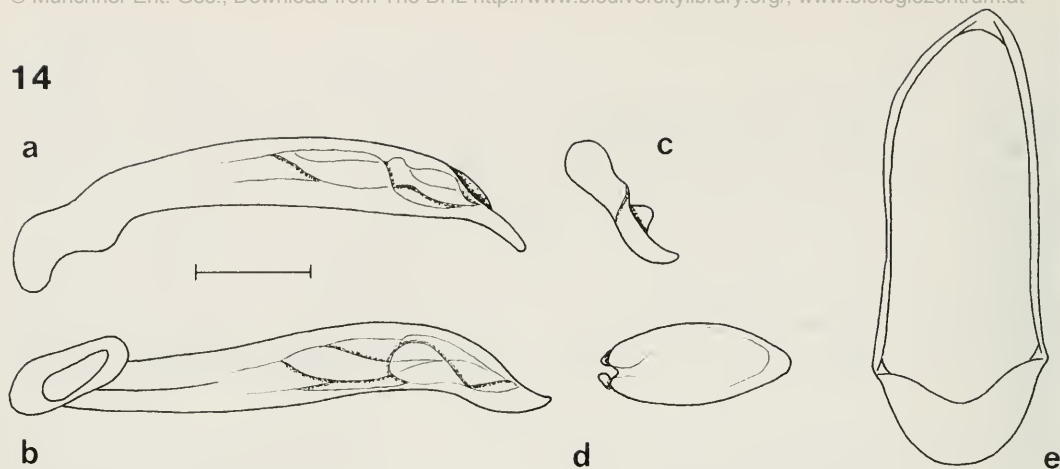

Fig. 14. *Pericalus philippinus* HELLER. ♂ genitalia. For explanations see Fig. 1. Scale: 0.5 mm.

Variation. Apart from sexual variation of shape of elytra only considerable variation of size noted. The large specimens also tend to have relatively broader pronota. Otherwise a very homogenous species.

Distribution. Philippines: Luzon and Negros.

Additional material examined (11). **Philippines:** 1♂, Cap Engano, Luzon, WHITEHEAD (CBM); 1♀, Los Banos Luzon, *Pericalus undatus* CHAUD. det. Ing. JEDLICKA (MNHB); 2♂♂, Luzon Los Banos, 13.11.1992, Mt. Makiling (2), leg. SCHILLHAMMER (NHMW); 3♂♂, 2♀♀, Philippinen n. Luzon (?)Ilewa Norte, det. *undatus* (CBM, MNHB); 1♀, Philippinen n. Luzon (?)Bellalan, det. *undatus* (MNHB); 1♀, Philippines Negros Is., 8.-10.V.1989, D. MOHAGAN, *Pericalus undatus* CHD. det. S. L. STRANEO 1992 (CBM).

16. *Pericalus philippinus* HELLER

Figs 14, 33

Pericallus philippinus HELLER, 1916, p. 274; CSIKI 1932, p. 1369; JEDLICKA 1963, p. 377.

Types. Lectotype (by present designation): ♀, Mt. Banahao P. L. BAKER, 1915 8, *philippinus* Typus (SMTD).

Note. Two additional specimens (SMTD) collected at the same locality and by the same collector bear the same locality label. They cannot serve as paralectotypes, however, because they have been purchased later and were also identified later.

Type locality: "Luzon: Mt. Banahao", Philippines.

Diagnosis. Easily distinguished by large size, bright green fore body, blackish elytra with green borders, and very serrate, markedly y-shaped elytral pattern.

Description:

Because the original description is detailed and quite good, only those characters are included that are not mentioned in the description, or that are primarily necessary for species distinction.

Measurements. Length: 10.0-10.4 mm; width: 3.9-4.05 mm. Ratios. Width/length of prothorax: 1.25-1.26; width head/prothorax: 1.28-1.29.

Colour and pattern. Head and pronotum bright metallic green with slight bluish lustre, labrum dark

15

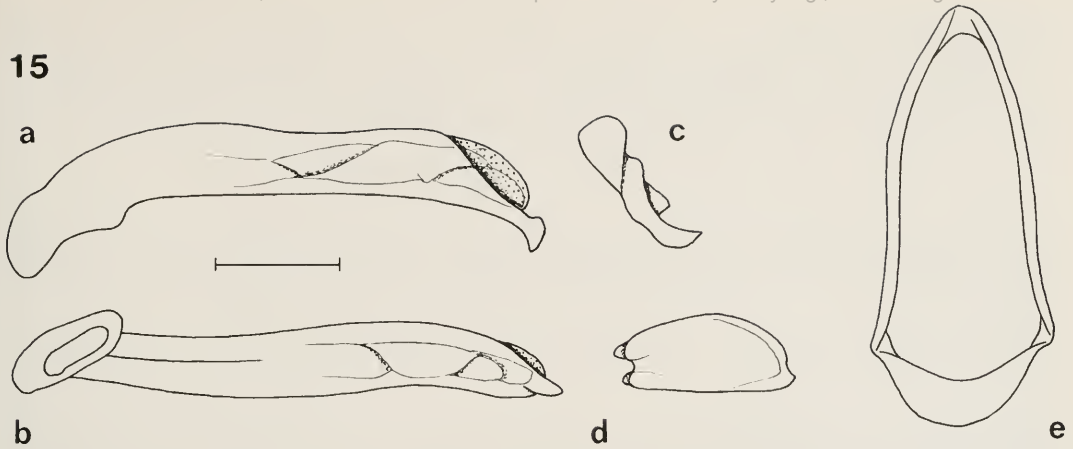

Fig. 15. *Pericalus picturatus* CHAUDOIR. ♂ genitalia. For explanations see Fig. 1. Scale: 0.5 mm.

piceous. Elytra black, though base, the narrow lateral margins, the apex, and about the anterior half of sutural interval green. Elytral spots orange. Antenna dark reddish-piceous. Legs dirty yellow, knees, tibiae, and tarsi contrastingly piceous. Elytra with two wide, very serrate stripes, as in fig. 33. Anterior stripe on 2nd-8th interval, posterior stripe on 1st-8th interval. The anterior stripe remarkably y-shaped.

Head. Clypeus in middle without microreticulation, though punctate and striolate. Frons and vertex with dense, coarse microreticulation and with very dense longitudinal, oblique, and transverse wrinkles. Medially of eyes with c. 8 strong elongate striae. Surface dull, only in middle of frons somewhat glossy.

Pronotum. Wide, lateral border near apex curved, prebasal sinuosity deep, posterior angles large, laterally strongly projecting, acute, though at the very tip slightly obtuse. Anterior transverse sulcus shallow, posterior sulcus very deep. Surface without microreticulation, densely and finely punctate, and with few fine, transverse wrinkles, glossy.

Elytra. Rather wide, somewhat depressed, laterally evenly curved. Both apical spines short. Intervals convex throughout, striae deep, smooth. 3rd interval with 3 punctures, both anterior punctures situated in 3rd stria and in anterior third, posterior puncture near 2nd stria in posterior third. Microreticulation distinct, though somewhat superficial, strongly transverse. Intervals with sparse puncturation. Surface rather dull.

♂ genitalia. Genital ring (Fig. 14e) elongate, rather parallel, apex widely rounded. Aedeagus elongate, in ventral view near apex markedly sinuate. Apex elongate, slightly deflexed ventrally. Parameres as in figs 14c-d.

♀ genitalia. Very similar to those of *P. quadrimaculatus* (MACLEAY).

Variation. Very little variation noted.

Distribution. Philippines: Luzon. Apparently known only from type locality.

Additional material examined (2). 1♂, Mt. Banahao P. L. BAKER, Coll. W. SCHULTZE Ankauf 1942 (SMTD); 1 (sex?), Mt. Banahao P. L. BAKER, *Pericallus philippinus* HELL. Det. W. SCHULTZE, Coll. W. SCHULTZE Ankauf 1942 (SMTD).

17. *Pericalus picturatus* CHAUDOIR

Figs 15, 34

Pericalus picturatus CHAUDOIR, 1869, p. 160; ANDREWES 1926, p. 287; CSIKI 1932, p. 1369; LOUWERENS 1964, p. 188.

Pericalus spiniger ANDREWES, 1926, p. 286; CSIKI 1932, p. 1369 (**syn. n.**).

© Münchner Ent. Ges., Download from The BHL <http://www.biodiversitylibrary.org/>; www.biologiezentrum.at
Types. Of *picturatus*: Holotype (by monotypy): ♂, Ex Musaeo CHAUDOIR, *picturatus*, Celebes WALLACE SCHAUM (MNHN).

Of *spiniger*: Holotype (by original designation): ♂, Laboean, Batjan, DOHERTY II III, Type, *Pericalus spiniger* ANDR. Type H. E. ANDREWES det. (BMNH). - Paratypes: 2♂♂, 1♀, same data, Cotype (BMNH); 1♂, same data, Cotype, Comp' with *figuratus* C. & *picturatus* C. (BMNH).

Type localities. Of *picturatus*: "Celebes". - Of *spiniger*: "Laboean, Batchian".

Note. Although ANDREWES (1926) in his description of *P. spiniger* stated that he had compared his *spiniger* with *picturatus* from the OBERTHÜR (CHAUDOIR) Collection and that he found both species different, they are actually not, as the comparison of the type series of *spiniger* with the holotype of *picturatus* revealed.

In his description of *P. picturatus* CHAUDOIR (1869) explicitly stated that he had only a single specimen, hence this is the holotype.

Diagnosis. Medium sized species with strongly y-shaped anterior elytral stripe and rather narrow, semilunar posterior stripe, distinguished from related species by size, densely wrinkled, dull pronotum with lateral borders anteriorly but faintly convex, piceous, rather glossy elytra with 3 anterior setiferous punctures at 3rd interval and an additional puncture at 5th interval, and slightly sinuate aedeagus with knob-like and on lower border acute apex.

Description:

Measurements. Length: 7.6-8.2 mm; width: 3.0-3.2 mm. Ratios. Width/length of prothorax: 1.12-1.21; width head/prothorax: 1.29-1.40.

Colour and pattern. Head and pronotum prevailing cupreous with some greenish reflexions, or green with some distinct cupreous areas. Labrum reddish. Antenna and palpi reddish throughout. Elytra piceous with slight green reflexions on lateral borders. Elytral stripes bright yellow. Legs dark yellow, tarsi slightly darker. Anterior elytral stripe on 3rd-8th intervals, posterior stripe on 3rd-7th intervals, both slightly overlapping onto 3rd interval, as in fig. 34. Anterior stripe distinctly y-shaped, though less serrate than in *P. figuratus*, posterior stripe less narrow than in *P. figuratus*.

Head. Wide, eyes very large. Microreticulation distinct, frons and vertex with dense, rather fine, longitudinal or slightly irregular wrinkles, medially of eyes with 5-6 fine, regular striae, surface dull.

Pronotum. Rather variable in width, moderately convex. Lateral border near apex barely convex, prebasal sinuosity rather deep, posterior angles large, acute, laterally moderately projecting. Anterior transverse sulcus very shallow, posterior sulcus deep. Microreticulation distinct, surface covered by extremely dense, irregularly transverse wrinkles, very dull.

Elytra. Moderately wide, fairly depressed; in males posteriorly but feebly widened, in anterior third not compressed, lateral border evenly curved, in the single female posteriorly moderately widened, anteriorly barely compressed. Both apical spines elongate, median spine very elongate. Intervals convex, striae deep, distinctly crenulate. 3rd interval in anterior third with 3 instead of 2 setiferous punctures adjacent to 3rd stria, posterior puncture on 2nd stria. Also 5th interval with a puncture situated between 2nd and 3rd puncture of 3rd interval. Microreticulation superficial, transverse, surface fairly glossy.

♂ genitalia. Genital ring (Fig. 15e) elongate, rather parallel, apex widely rounded. Aedeagus rather large, in ventral view moderately sinuate, apex short, remarkably knob-shaped, lower border acute. Parameres as in figs 15c-d.

♀ genitalia. Very similar to those of *P. quadrimaculatus* (MACLEAY).

Variation. Little variation noted in colour of pronotum and elytra; relative width of pronotum, however, is markedly variable in this species, although shape and structure of surface of pronotum is very similar throughout.

Distribution. Sulawesi (Celebes), Moluccas: Batjan; ? New Guinea. One non-typical specimen determined as *picturatus* and labelled "Dorey" and "Nov. Guin." is perhaps mislabelled, because no *picturatus* has been ever found in New Guinea, where *figuratus* is common. Perhaps the localities of *picturatus* and *figuratus* have been simply mistaken (see note under *figuratus*).

16

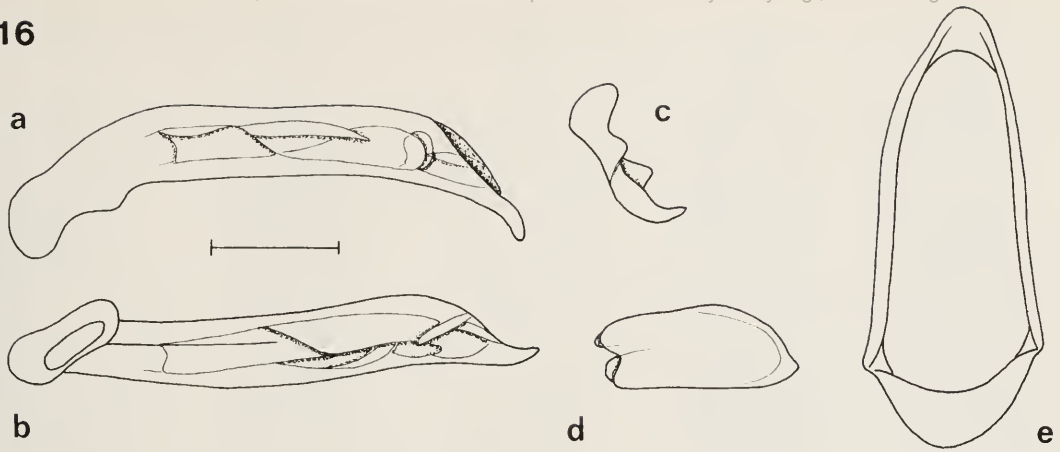

Fig. 16. *Pericalus figuratus* CHAUDOIR. ♂ genitalia. For explanations see Fig. 1. Scale: 0.5 mm.

Additional examined material (1). New Guinea: 1♂, 41746, Nov. Guin. Coll. SCHAUM, *picturatus* SCHAUM, *picturatus* CHD. Dorey (MNHB).

18. *Pericalus figuratus* CHAUDOIR

Figs 16, 35

Pericalus figuratus CHAUDOIR, 1861, p. 124; ANDREWES 1926, p. 287; CSIKI 1932, p. 1369; JEDLICKA 1953, p. 145; LOUWERENS 1964, p. 188; DARLINGTON 1968, p. 110.

Types. Lectotype (by present designation): ♀, Ex Musaeo CHAUDOIR, *figuratus*, Celebes WALLACE, Muséum Paris 1952 Coll R OBERTHÜR (MNHN).

Type locality: "Celebes".

Note. As DARLINGTON (1968) stated, the type locality "Celebes" is most probably wrong, because this species has not been reported since WALLACE's time in Sulawesi nor elsewhere in the Moluccas, although it is common throughout New Guinea. There are, however, some specimens from the SCHAUM collection in the MNHB labelled "Gilolo" which is an old name for Halmahera. Although *P. figuratus* has not been recollected on this island recently, it is possible that it occurs still there.

Diagnosis. Medium sized species with extremely y-shaped anterior elytral stripe and narrow, semilunar posterior stripe, distinguished from related species by size, bright green, smooth, highly glossy pronotum with acute, markedly projecting posterior angles, black, strongly microreticulate elytra, and barely sinuate aedeagus with apex slightly curved down.

Description:

Measurements. Length: 7.5-8.0 mm; width: 2.95-3.2 mm. Ratios. Width/length of prothorax: 1.14-1.18; width head/prothorax: 1.35-1.39.

Colour and pattern. Head and prothorax bright green, medially of eyes with more or less extended golden or cupreous reflexions, pronotum of some specimens even largely cupreous. Labrum reddish. Antenna and palpi reddish throughout. Elytra completely black, elytral stripes reddish-orange. Legs reddish, tarsi slightly darker. Elytral stripes wide, on 2nd-8th intervals, anterior stripe markedly y-shaped, anteriorly deeply excised, posterior stripe narrowly semilunar, as in fig. 35.

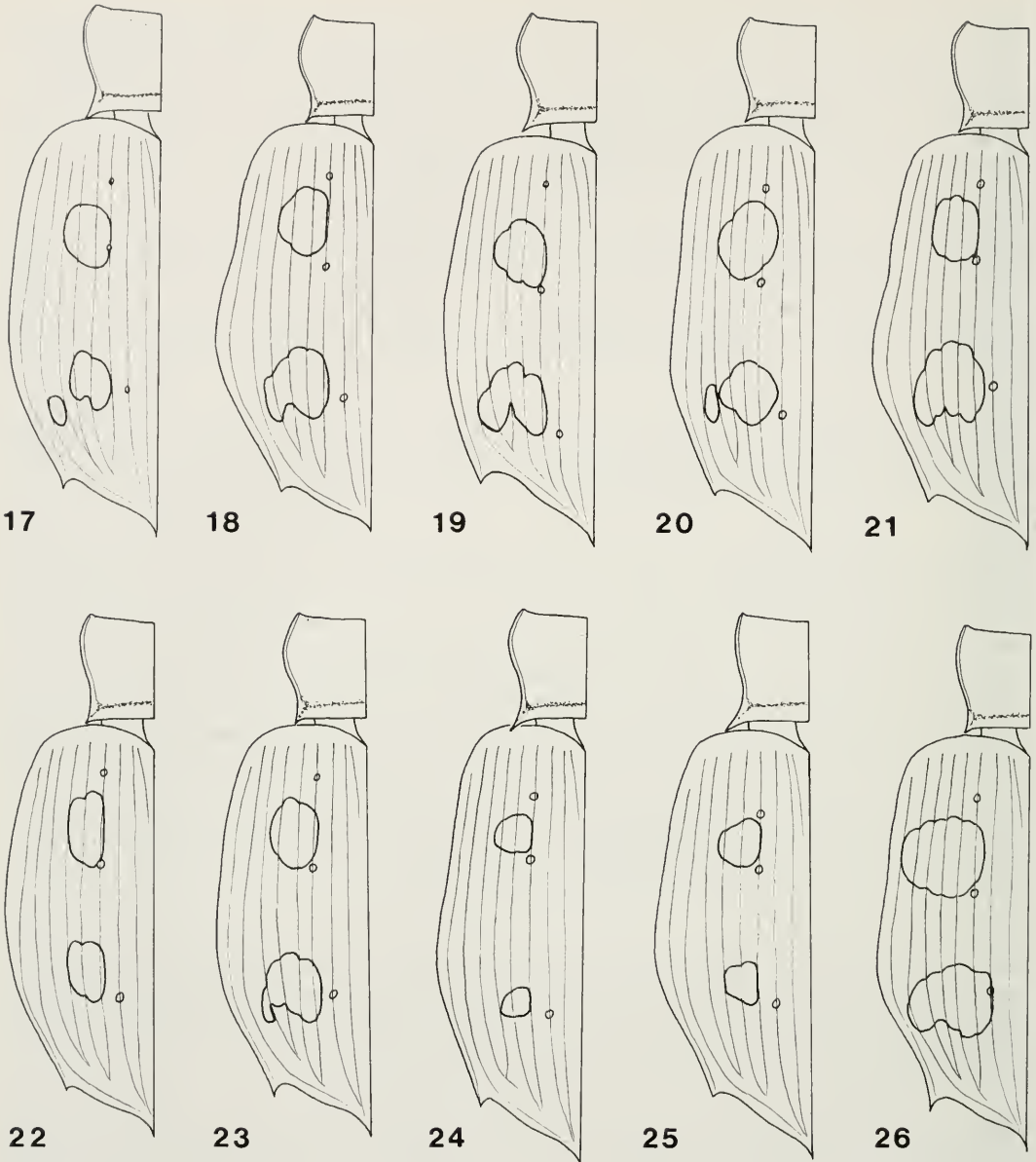

Figs 17-26. Habitus. 17, 18. *Pericalus quadrimaculatus* (MACLEAY). 17. ♂. 18. ♀. 19. *P. robustus*, sp. n., ♂ holotype. 20. *P. signatus* JEDLICKA, ♂. 21. *P. latus* SCHAUM, ♀ lectotype. 22. *P. gratus* SCHAUM, ♂ lectotype. 23. *P. magnus*, sp. n., ♂ holotype. 24. *P. tetrastigma* CHAUDOIR, ♂. 25. *P. atricornis*, sp. n., ♀ holotype. 26. *P. levifrons* HELLER, ♀ lectotype. Whole body sizes: 17. 5.8 mm. 18. 6.5 mm. 19. 8.7 mm. 20. 6.1 mm. 21. 8.7 mm. 22. 6.5 mm. 23. 10.3 mm. 24. 7.6 mm. 25. 10.4 mm. 26. 7.0 mm.

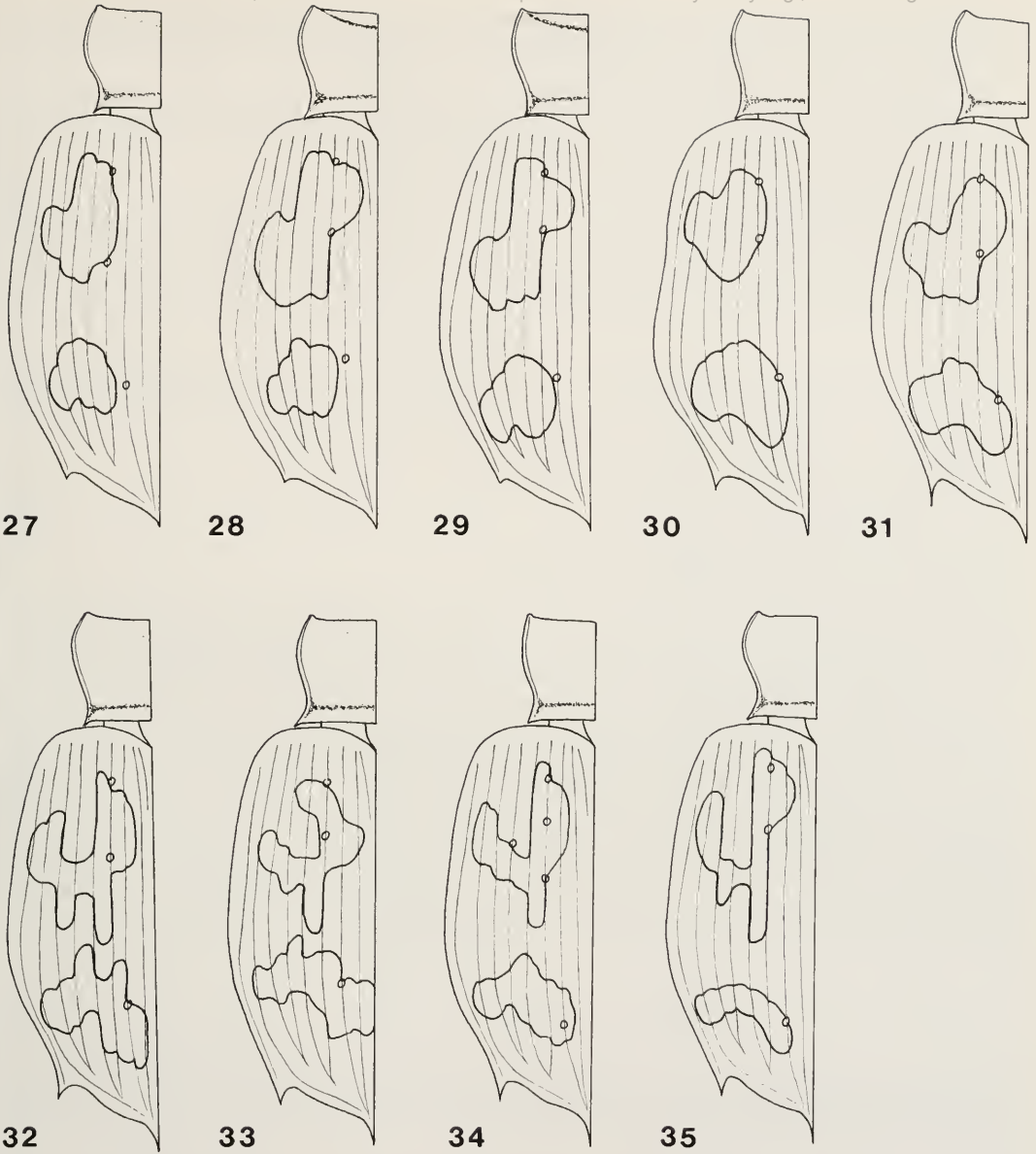

Figs 27-35. Habitus. 27. *Pericalus xanthopus* SCHAUM, ♂. 28. *P. depressus* ANDREWES, ♂. 29. *P. angusticollis*, sp. n., ♂ holotype. 30. *P. klapperichi* JEDLICKA, ♀ lectotype. 31. *P. cuprascens*, sp. n., ♂ holotype. 32. *P. undatus* CHAUDOIR, ♂. 33. *P. philippinus* HELLER, ♂. 34. *P. picturatus* CHAUDOIR, ♂ holotype. 35. *P. figuratus* CHAUDOIR, ♂. Whole body sizes: 27. 5.9 mm. 28. 7.6 mm. 29. 5.8 mm. 30. 7.1 mm. 31. 7.3 mm. 32. 6.7 mm. 33. 10.0 mm. 34. 7.8 mm. 35. 7.6 mm.

Head. Very wide as compared with prothorax, eyes very large. Microreticulation rather indistinct, frons and vertex with moderately dense, though rather coarse longitudinal or oblique wrinkles, medially of eyes with 3-4 strong longitudinal striae. Surface rather glossy.

Pronotum. Narrow, moderately convex. Lateral border near apex convex, prebasal sinuosity very deep, posterior angles large, very acute, laterally far projecting. Anterior transverse sulcus moderately deep, posterior sulcus deep. Microreticulation almost absent, surface with few, rather fine transverse or irregular wrinkles and with fine, scattered puncturation, very glossy.

Elytra. Moderately wide, fairly depressed; in males posteriorly but feebly widened, in anterior third not compressed, lateral border evenly curved, in females elytra posteriorly distinctly widened. Both apical spines very elongate. Intervals convex, striae rather deep, faintly punctate-crenulate. 3rd interval with 3 punctures, both anterior punctures situated in 3rd stria and in anterior third, posterior puncture near 2nd stria in posterior third. Microreticulation distinct, very transverse, surface remarkably dull compared with fore body.

♂ genitalia. Genital ring (Fig. 16e) elongate, rather parallel, apex widely rounded. Aedeagus rather large, in ventral view barely sinuate, apex acute, fairly elongate, in lateral aspect rather deflexed ventrally and slightly turned to right. Parameres as in figs 16c-d.

♀ genitalia. Very similar to those of *P. quadrimaculatus* (MACLEAY).

Variation. Apart from some differences in shape of elytra, little variation noted in colour of fore body, shape of posterior angles, and microsculpture of pronotum.

Distribution. New Guinea, ?Halmahera, ?Celebes. The last record is very doubtful, the old records from Halmahera are perhaps more reliable (see note above).

Additional material examined (27). **Halmahera:** 1♂, 41745, Gilolo Coll. SCHAUM, *figuratus* CHAUD. (SCHAUMs hand) (MNHB); 1♂, 2♀♀, Hist. Coll. 41745 Gilolo Coll. SCHAUM, det. *figuratus* (MNHB). - **Sulawesi:** 1♀, Bornio, *Pericalus figuratus* CHD. Celebes, Coll. L. W. SCHAUFUSS (MNHB). - **New Guinea:** 2♂♂, 1♀, Irian Jaya, Paniai Pr., Nabire, Pusppensaat km 60, 200 m, 15.8.1991, leg. A. RIEDEL (CBM); 1♀, Irian Jaya, Paniai Pr., Nabire, Pusppensaat Base Camp km 54, 15.8.1991, leg. A. RIEDEL (CBM); 3♂♂, 2♀♀, Irian Jaya, Jayapura, Sentani, Cyclops-Mts., 19.-21.9.1990, leg. A. RIEDEL (CBM, ZSM); 2♂♂, Irian Jaya, Manokwari, Ransiki Mayubi, Benyas, 300 m, 28.9.1990, leg. A. RIEDEL (CBM); 4♀♀, Irian Jaya, Manokwari, Ransiki Mayubi, 26.-30.10.1990, leg. A. RIEDEL (CBM); 1♀, Irian Jaya, Jayawijaya Prov., Endoman, 800-1200m, 14.-15.9.1992, leg. A. RIEDEL (CBM); 1♀, Irian Jaya, Merauke-Pr., Dehai, Brazza River, 21.-22.6.1994, leg. A. RIEDEL (CBM); 1♂, Neuguinea, Lumi, 1.1973, leg. H. OHLMUS (CBM); 1♀, D. N. Guinea Sattelberg, *Pericalus* sp. nov. very n^r *figuratus* CHD. H. E. ANDREWES det. (MNHB); 1♀, D. N. Guinea Sattelberg, *Pericallus* sp. very near *P. spiniger* ANDR 445 (MNHB); 1♀, D. N. Guinea Wareo, *Pericalus* sp. n. near *figuratus* CHD. 234. ANDR. (MNHB); 1♀, Garaina, 1979 J. SEDLACEK (NHMB).

Phylogeny

The subgenus *Coeloprotopus* is certainly a monophyletic unit well distinguished from the nominate subgenus that is presumably plesiomorphic in some respects. The main synapomorphies of *Coeloprotopus* are presumably the narrow pronotal margin, the rather convex body shape, and the metallic colour of most species.

Within the subgenus *Coeloprotopus*, however, it is difficult to deal with the phylogenetic relations at the species level because of the very close relationships of most species. It is possible, however, to do this at least at the level of species-groups.

In the following list (Tab. 1) some important characters are listed that exhibit postulated apomorphic states, and their distribution in the species is shown in tab. 2. On the basis of these character states the cladogram for the subgenus *Coeloprotopus* (Fig. 36a, b) has been constructed using the methods of the cladistic analysis as proposed by HENNIG (1966).

Table 1. Character states used in the construction of the cladogram for the species of the subgenus *Cocloprosopus*. Different apomorphic states are distinguished by lower-case letters. States of a morphocline are indicated by a number.

Character	Plesiomorphic status	Apomorphic states
1. Size	medium, 6-8.5 mm	very small, length <6 mm 1a very large, length >8.7 mm 1b
2. Colour of surface	dark blue-metallic	completely bright green-metallic 2 blackish or piceous, non-metallic 2'
3. Colour of antenna	brownish apart from three basal segments	completely black 3
4. Colour of legs	completely black	reddish 4
5. Size of elytral spots	medium sized	large 5
6. Shape of anterior elytral spot	about circular	elongate 6a moderately elongate, slightly s-shaped 6a ¹ elongate, distinctly s-shaped 6a ² moderately elongate, slightly y-shaped 6b ¹ elongate, distinctly y-shaped 6b ² very elongate, markedly y-shaped 6b ³
7. Shape of posterior elytral spot	rather circular	wide, slightly lunate 7 ¹ lunate, markedly serrate 7 ² narrow, markedly lunate 7 ³ very narrow, extremely lunate 7 ⁴
8. Frons	with strong microsculpture	almost devoid of microsculpture 8
9. Anterior pronotal sulcus	shallow	deep 9
10. Sculpturation of pronotum	with weak transverse sulci	with numerous, very strong transverse sulci 10
11. Striation of elytra	deep, intervals convex	weak, intervals barely convex 11
12. Additional setiferous puncture on 3rd interval	absent	present 12
13. Setiferous punctures on 5th interval	absent	present 13
14. Microreticulation on elytra	present, distinct	reduced 14
15. Apical spines of elytra	short	elongate 15
16. Row of elongate hairs on epipleura of elytra	absent	present 16
17. Shape of ♂ genital ring	symmetric, apex rounded	asymmetric 17a apex narrowed, fairly acute 17b ¹ apex strongly narrowed, acute 17b ² wide, apex widened 17c moderately sinuate 18 ¹ markedly sinuate 18 ²
18. Shape of aedeagus	rather straight, little contorted	strongly rasp-like 19
19. Surface of aedeagus	rather smooth	present, strongly developed 20
20. Crest on upper surface of aedeagus	absent	
21. Apex of aedeagus	without special features	bent 21a edged on upper surface 21b slightly hook-shaped 21c ¹ strongly hook-shaped 21c ² strongly hook-shaped and swollen 21d

2. Colour of elytral surface. The dark blue-metallic colour of the *tetrastigma*-group is apparently the plesiomorphic status within the subgenus, because it occurs also predominantly in the nominate subgenus. The bright green-metallic colour of many species is apomorphic though it occurs in several species-groups and mostly in species that are rather plesiomorphic in other respects. The blackish colour in certain species of the *undatus*-group is again apomorphic, mainly because it is combined with a very apomorphic elytral pattern.
6. Anterior elytral spot. The circular shape of this spot is presumably plesiomorphic, the elongate, s-shaped forms in the *xanthopus*-group and the y-shaped form in the *klapperichi*- and *undatus*-groups are apomorphic. In the latter species-groups the spot shows a fine morphocline towards extremely serrate y-shaped form from *P. klapperichi* to *P. figuratus*.
7. Posterior elytral spot. The more or less circular shape is also presumably plesiomorphic, the lunate or serrate-lunate shape in the *undatus*-group is apomorphic and shows a morphocline towards the very narrow, extremely lunate form in *P. figuratus*.
12. and 13. Additional setiferous punctures on 3rd and 5th intervals. These are certainly apomorphic states of *P. picturatus*.
17. Shape of aedeagus. The rather straight form of the aedeagus is perhaps plesiomorphic, whereas the sinuate and contorted forms are apomorphic. Also all modifications of the apex are apomorphic, though perhaps being convergently evolved within some species groups.

The cladogram (Fig. 36a, b) reveals the following phylogenetic relationships and thus the grouping into several monophyletic groups and subgroups:

The *tetrastigma*-group is presumably the most plesiomorphic group, whereas all other species form a monophyletic unit.

The *undatus*-subgroup (*P. undatus*, *P. philippinus*, *P. picturatus*, *P. figuratus*) (Fig. 36b) forms a monophyletic unit, in which *P. undatus* is apparently the adelphotaxon of the three other species, *P. philippinus* is the adelphotaxon of *P. picturatus* and *P. figuratus*, and *P. figuratus* shows in some external characters

Table 2. Character states of the species of the subgenus *Coeloprosope*, numbered as in tab. 1. -: plesiomorphic state; numbers: apomorphic states; ?: state unknown. Other abbreviations as in tab. 1.

Species	Number of characters																				
	1	2	3	4	5	6	7	8	9	10	11	12	13	14	15	16	17	18	19	20	21
<i>tetrastigma</i>	-	-	-	-	-	-	-	-	-	-	-	-	-	-	-	16	-	18 ¹	-	-	21a
<i>atricornis</i>	1b	-	3	-	-	-	-	-	-	-	-	-	-	-	-	16	?	?	?	?	?
<i>quadrinaculatus</i>	-	2	-	4	-	-	-	-	-	-	-	-	-	-	-	-	-	-	-	-	-
<i>robustus</i>	1b	2	-	4	-	-	-	-	-	-	-	-	-	-	-	-	-	-	-	-	21b
<i>signatus</i>	-	2	-	4	-	-	-	-	-	-	-	-	-	-	-	-	17a	-	-	-	21b
<i>laetus</i>	1b	2	-	4	-	-	-	-	-	-	-	-	-	-	-	-	-	18 ¹	-	-	-
<i>gratus</i>	-	2	-	4	-	-	-	-	-	-	-	-	-	-	-	-	-	18 ²	-	-	21a
<i>magnus</i>	1b	2	-	4	-	-	-	-	-	-	11	-	-	-	-	-	-	18 ²	-	-	21a
<i>levisfrons</i>	-	2'	-	4	5	-	-	8	-	-	-	-	-	-	-	-	?	?	?	?	?
<i>xanthopus</i>	-	2	-	4	5	6a ¹	-	-	-	-	-	-	-	-	-	-	17c	-	-	-	21c ²
<i>depressus</i>	-	2	-	4	5	6a ²	-	-	9	10	-	-	-	-	-	-	17b ¹	-	19	20	21c ¹
<i>angusticollis</i>	1a	2	-	4	5	6a ²	-	-	9	10	-	-	-	-	-	-	17b ²	-	19	20	21c ¹
<i>klapperichi</i>	-	2'	-	4	5	6b ¹	7 ¹	-	-	-	-	-	-	14	-	-	-	-	-	-	-
<i>cuprascens</i>	-	2'	-	4	5	6b ¹	7 ¹	-	-	-	-	-	-	14	-	-	-	-	-	-	-
<i>undatus</i>	-	2'	-	4	5	6b ²	7 ²	-	-	-	-	-	-	-	-	-	-	-	18 ¹	-	21a
<i>philippinus</i>	1b	2'	-	4	5	6b ²	7 ³	-	-	-	-	-	-	-	-	-	-	-	18 ¹	-	-
<i>picturatus</i>	-	2'	-	4	5	6b ²	7 ⁴	-	-	-	-	12	13	14	15	-	-	-	-	-	21d
<i>figuratus</i>	-	2'	-	4	5	6b ³	7 ³	-	-	-	-	-	-	-	15	-	-	-	-	-	-

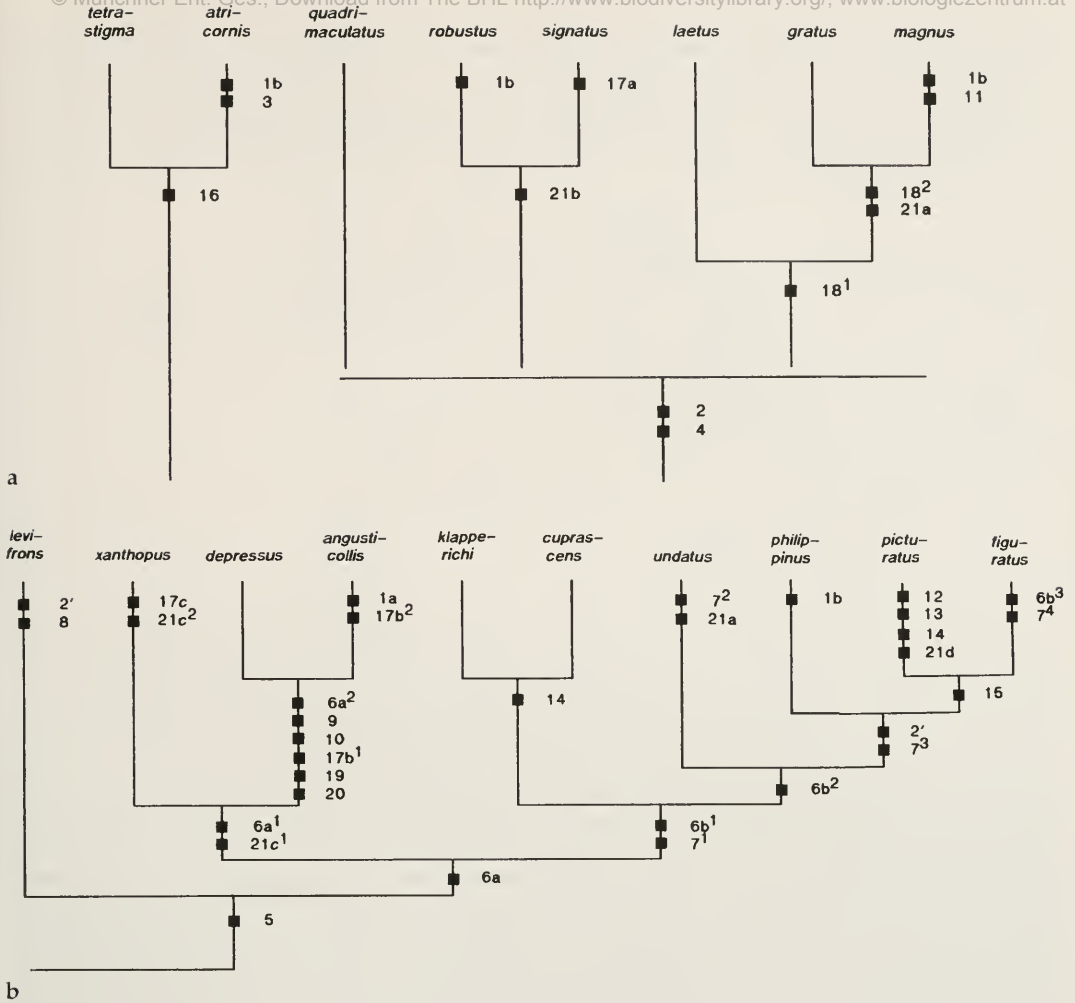

Fig. 36a, b. Cladogram of the supposed relationships of the subgenus *Coeloprosope* CHAUDOIR. For explanations of numbers see tables 1 and 2.

the most apomorphic states of a morphocline. Both latter species are perhaps the most highly evolved species of the whole subgenus.

The *klapperrichi*-subgroup (*P. klapperrichi*, *P. cuprascens*) (Fig. 36b) is a monophyletic unit and forms the adelphotaxon of the *undatus*-subgroup.

The *xanthopus*-subgroup (*P. xanthopus*, *P. depressus*, *P. angusticollis*) (Fig. 36b) is certainly a monophyletic unit. *P. xanthopus* is more plesiomorphic in some external respects and is the adelphotaxon of the closely related species *P. depressus* and *P. angusticollis*. Presumably the *xanthopus*-subgroup is the adelphotaxon of the *undatus* + *klapperrichi*-subgroups, but this opinion is based on a rather weak synapomorphy.

P. laevifrons (Fig. 36b) is a rather isolated species but may be most closely related to the *undatus* + *klapperrichi* + *xanthopus*-lineage. All mentioned species are certainly related and form the monophyletic *undatus*-group.

The relationships of the rest of the species having medium-sized or small, circular elytral spots (Fig. 36a) are less well understood. Most relationships expressed in the cladogram rely on characters of the ♂ genitalia and are rather weak or may be actually due to convergent evolution. However, within this assemblage the *laetus*-group (*P. laetus*, *P. gratus*, *P. magnus*) might be monophyletic with *P. laetus* more

© Münchner Ent. Ges., Download from The BHL <http://www.biodiversitylibrary.org/>; www.biologiezentrum.at
 plesiomorphic than both other species, while the rest of the species (*P. quadrimaculatus*, *P. signatus*, *P. robustus*) are more difficult to treat. So far they lack any common synapomorphic character and are perhaps an assemblage of more or less plesiomorphic species, though *P. signatus* and *P. robustus* may be more closely related and form a separate *signatus*-group, while *P. quadrimaculatus* is presumably the most plesiomorphic species of the whole subgenus except for the species of the *tetrastigma*-group.

For better comprehension of the results of the cladogram the division into species-groups and subgroups is outlined in the table below:

Table 3. Grouping of the species of *Coeloprosopus* into species-groups and subgroups.

group	subgroup
<i>tetrastigma</i>	
<i>quadrimaculatus</i>	
<i>signatus</i>	
<i>laetus</i>	<i>laetus</i>
	<i>gratus</i>
<i>undatus</i>	
	<i>levifrons</i>
	<i>xanthopus</i>
	<i>klapperichi</i>
	<i>undatus</i>

Evolution of some characters states in *Coeloprosopus*

In the following, some ideas to adaptive significance and evolution of certain character states or morphoclines in the subgenus *Coeloprosopus* are presented that could be used for further evaluation of the phylogenetic reasoning.

Body shape. The characteristic habitus of the species of *Coeloprosopus* is due to a combination of certain character states like general body shape, size of eyes, shape of elytral apex etc. The general habitus is in *Coeloprosopus* rather "catascopoid", that is: the body is rather elongate and convex with narrow, convex prothorax, narrow lateral borders of pronotum and elytra, a fairly small head with large, markedly protruding eyes, and spinose external and sutural apices of the elytra. The term "catascopoid" does not implicitly mean that the genus *Pericalus* is most closely related to the genus *Catascopus* (see introduction), but could describe a very striking similarity due to convergent evolution. At any rate, however, both genera are related to some degree, even when *Catascopus* is perhaps not the adelphotaxon of *Pericalus*.

In the nominate subgenus *Pericalus*, however, body shape is rather wide and depressed, with wide, heart-shaped pronotum and rather broad, flattened, posteriorly widened elytra, wide, reflexed lateral borders of pronotum and elytra, rather wide head with relatively less protruding eyes, and generally not or only faintly spinose elytra. This is certainly a more normal body shape and it recalls the shape of many species of *Coptodera* (s. l.), the apparent adelphotaxon of *Pericalus*. Within *Coeloprosopus* a further trend is seen towards further evolution of this catascopoid habitus with even narrower, more parallel elytra, larger eyes, and markedly spinose elytral apices. The transformation from a more depressed "coptoderid" to a more convex "catascopoid" or even "cicindeloid" body shape could have been caused by a change from more subcortical and/or nocturnal habits to the habits of a free-moving, sharp-eyed, diurnal predator.

Within *Coeloprosopus* there is a marked trend towards more spinose elytral apices. Spinose elytra are a common character of tropical arboreal carabids (see for example ERWIN 1979 for South American, and DARLINGTON 1968, 1971 for New Guinean Carabidae) that commonly arise when Carabidae become arboreal, in particular free living on trunks and leaves. According to ERWIN (1979) such spines might be a protective means against predation. The trend towards markedly spinose elytra in certain species-groups of *Coeloprosopus* may be due to the same change of habits as mentioned above.

Colour and pattern. In *Pericalus* s. str. colour of the surface is generally black or at most dark blue or



Fig. 37. Approximate ranges of the subgenera *Pericalus s. str.*: ----; and *Coeloprosopus*: ———.

blue-violet. Although in the large genus *Coptodera* elytra are commonly metallic, certain species are also black which is regarded the plesiomorphic state in both genera. Hence the highly metallic green or green-golden or green-cupreous colour of many species of *Coeloprosopus* is apomorphic and it is perhaps an adaptation to diurnal habits, because greenish-metallic colour is thought to be a highly successful protective colour of tree inhabiting, diurnal insects. The various changes of this bright green colour to blackish-green in some subgroups of the *undatus*-group may be of further evolutionary value, because they occurred apparently in combination with the evolution of the complicate elytral pattern (see below). The dark bluish colour of the *tetrastigma*-group, however, is presumably a very plesiomorphic character state preserved only in this species-group.

Although few species of *Pericalus s. str.* as well as of *Coptodera s. l.* have unspotted elytra, the common and perhaps original pattern is the four-spotted type, in which the spots are rather circular. This pattern is for example still present in the Oriental *Coptodera tetrastigma* CHAUDOIR. It is also present in certain species of *Pericalus s. str.* and likewise in the species of the *quadrifasciatus*-, *signatus*-, *laetus*-, and *tetrastigma*-groups of *Coeloprosopus*. Within the *undatus*-group a transformation to a very irregular elytral pattern occurred, which ends in the highly serrate pattern of the species of the *undatus*-subgroup. Certainly this pattern type is more cryptic than the normal four-spotted pattern, and hence, it can be argued that within *Coeloprosopus* a transformation took place from a cryptic pattern by use of bright, metallic colours to a likewise cryptic pattern that uses sombre colours but a highly intricate pattern.

Thus, evolution of colour and pattern within *Coeloprosopus* could be likewise interpreted as caused by the change from nocturnal, subcorticolous habits to free-living, diurnal habits. However, more information upon the actual way of life of *Pericalus*-species as well as of the species of the related genera should be accumulated for settling of these ideas.

Distribution

Although specimens of the genus *Pericalus* are rather common in rain forest areas and are fairly commonly collected, the number of specimens available is surprisingly low in several species. Whereas some species are common and widely distributed, others are apparently rare and/or have very limited ranges.

The genus as a whole occupies the area between India in the northwest, Indochina, Taiwan and the Philippines in the east, New Guinea and New Britain in the southeast, and Java and Lombok in the south,

but the genus does not occur in Australia. The two subgenera, however, have rather different ranges (Fig. 37). The 12 known species of *Pericalus* s. str. occur from India to Taiwan, perhaps on Palawan (the westernmost island of the Philippines), on Sumatra, Borneo and Java. So they occupy the northern and western part of the common range, and as many as half of the recorded species occur on the mainland. Actually, their eastern border almost exactly agrees with WALLACE'S line. The common range of the subgenus *Coeloprosopus*, however, occupies large areas to the west and the east of this line which has been not important as a barrier at least for this subgenus as a whole, though, nevertheless, for some species-groups.

The recorded ranges of the species of the subgenus *Coeloprosopus* are tabulated below and they are once more summarized for the faunal subregions in an additional table below:

Table 4. Distributions of the species of the subgenus *Coeloprosopus*.

<i>tetrastigma</i>	Malaysia, Sumatra, Borneo
<i>atricornis</i>	Sumatra
<i>quadrinaculatus</i>	Malaysia, Burma, Thailand, Sumatra, Java, Borneo
<i>robustus</i>	Java
<i>signatus</i>	Philippines: Palawan, Samar
<i>lactus</i>	Sulawesi (Celebes), southern Borneo
<i>gratus</i>	Sulawesi (Celebes)
<i>magnus</i>	Sulawesi (Celebes)
<i>levifrons</i>	Philippines: Mindanao
<i>xanthopus</i>	Sumatra, Borneo, ?Sulawesi (Celebes)
<i>depressus</i>	Malaysia, Sumatra, Borneo
<i>angusticollis</i>	Malaysia, Borneo
<i>klapperichi</i>	New Britain
<i>cuprascens</i>	Irian Jaya (New Guinea): Biak Island
<i>undatus</i>	Philippines: Luzon, Negros
<i>philippinus</i>	Philippines: Luzon
<i>picturatus</i>	Sulawesi (Celebes)
<i>figuratus</i>	New Guinea, ?Halmahera

Table 5. Pattern of species abundance of the subgenus *Coeloprosopus* in the different faunal subregions.

Subregion	No. of species	No. of endemics
Asian mainland	4	0
Sundaland	8	2
Wallacea	9	6
Papuan	3	3

The tables above reveal that only 4 of the 18 species occur on the Asian mainland and virtually only *P. quadrinaculatus* has a wider range on the mainland beyond Malaysia. But even this species does not occur further west than Malaysia, or east than Thailand. The species of this subgenus are, therefore, substantially insular. The table reveals also that the bulk of the species and of the endemic species is in the Wallacea (Sulawesi and the Philippines), whereas the number of species, but more evidently the number of endemics is decreasing to the west and the east.

In an additional table the distribution pattern for the different species-groups is shown and the approximate ranges of the different species-groups and subgroups are depicted in fig. 38:

Fig. 38. Approximate ranges of the species-groups and subgroups of the subgenus *Coeloprosopus*. a. *quadrinaculatus*- + *signatus*-groups: - - - -; and *undatus*- + *levifrons*-subgroups: ———. b. *tetrastigma*-group: ———; and *lactus*-group: - - - -. c. *xanthopus*-subgroup: ———; and *klapperichi*-subgroup: - - - -.



Table 6. Distribution pattern of the species of the subgenus *Coeloprosopus* according to species-groups.

Species-group	N	Mainland	Sundaland	Wallacea	Papuan
<i>tetrastigma</i>	2	1	2	–	–
<i>quadrinaculatus</i>	1	1	1	–	–
<i>signatus</i>	2	–	1	1	–
<i>laetus</i>	3	–	1	3	–
<i>undatus</i>	10	2	3	5	3
Total	18	4	8	9	3

Zoogeography

For biogeographical questions, it would be useful to know, where the genus *Pericalus* originated and in which way it distributed over its present range.

Although all species are fully winged, their dispersal ability may be rather poor, because they are log inhabiting rain forest dwellers. Hence, dry country barriers may be of the same importance for the distribution of the species as are water barriers. But, on the other hand, beetles could drift over long distances on logs or other plant material.

For the evaluation of the historic events in biogeography I regard knowledge of the phylogenetic status of the species highly important. Hence, in general, I follow the considerations of HENNIG (1966) and BRUNDIN (1966) in that plesiomorphy of a taxon and place of origin are rather correlated, that the most apomorphic taxa are therefore usually found at the margins of the range of the supraspecific taxon, and that this pattern of distribution is mainly caused by vicariance biogeography and may sometimes reflect a continuous distribution on old land masses that are today dismembered. However, in some instances, it may be caused even by dispersal biogeography, e.g. when new areas are colonized that are later separated by geographical or ecological barriers, or when species are transported drifting on terranes over certain distances.

For these reasons, the knowledge of the the ground plan ("Grundplan" of HENNIG) of the genus is important to know the most plesiomorphic taxon. This ground plan should not only include morphological characters, but, if possible, also those characters concerning biology in the widest sense, including ecology, ethology, reproduction etc.

Although there is little information upon the latter non-morphological characters, I think that the nominate subgenus *Pericalus* s. str. as the whole preserves more characters of the original stock of *Pericalus* than either species of the subgenus *Coeloprosopus*. Within the latter subgenus the *tetrastigma*-subgroup includes perhaps the most plesiomorphic species. Within the rest of the species with bright green colouration *P. quadrinaculatus* is most plesiomorphic, followed by *P. robustus*, *P. signatus*, *P. laetus*, *P. gratus*, and *P. magnus*, although the latter species show some apomorphic character states and may be arranged in a series towards increasing apomorphy. A higher grade of apomorphy is achieved by *P. levifrons*. The species of the *xanthopus*- and *klapperichi*-subgroups show an even higher grade of apomorphy, and those of the *undatus*-subgroup are certainly the most highly evolved species of the whole genus.

When the data on phylogenetic states and relationships and those of the distribution of the species-groups and species are combined, the following picture of the evolution and biogeographic history may result:

The genus *Pericalus* as a whole originated presumably on the Asian mainland, where half of the species of the plesiomorphic subgenus *Pericalus* s. str. still occur. The area of origin was most probably the region of Indochina (Burma, Thailand, Laos), from where some species invaded India to the northwest and Taiwan in the east. There is a minor possibility that the genus as a whole originated in the area between (southern) Malaysia, Sumatra, Java, and Borneo that during parts of the Pleistocene formed a continuous land mass, the so-called Sundaland. Indeed, several species of the nominate subgenus, as well as of the subgenus *Coeloprosopus* today concentrate in this area. However, if this assumption should be true, then we must ask why several species of *Pericalus* s. str. reached the mainland and distributed there over considerable distances, but only one species of *Coeloprosopus* (*P. quadrinaculatus*) was able to do this and

© Münchner Ent. Ges., Download from The BHL <http://www.biodiversitylibrary.org/>; www.biologiezentrum.at only to in a limited range - a problem difficult to explain. But for solving the question of the origin of the genus *Pericalus* the phylogenetic relations within the subgenus *Pericalus* s. str. should be known at first, which are still unknown.

Assuming that the genus originated in Indochina, then we must argue that some species of *Pericalus* s. str. reached the Greater Sunda Islands, but neither the Philippines - apart from Palawan, the most westerly island of this group which is actually nearer to Borneo than to the larger Philippine islands and belongs geographically rather to the Sunda Islands - nor Sulawesi, nor the Australian region. Thus, the subgenus *Pericalus* s. str. did not transgress the WALLACE's line but its spreading came to an end exactly at the west to this line.

In the subgenus *Coeloprosoopus* the situation is rather different. Actually the number of species in the Philippines and on Sulawesi is almost as large as the number of species in Malaysia and on each of the Greater Sunda Islands, whereas only one species has spread more extensively on the mainland, but occurs also on the islands. Hence the subgenus *Coeloprosoopus* may have originated on the so-called previous Sundaland (southern Malaysia, Sumatra, Java, Borneo), where the number of species is today largest, but the diversity of species-groups is rather low - even lower than on the single island Sulawesi - and where both, the *klapperichi*- and the *undatus*-subgroups, i.e. the most highly evolved species groups, do not occur. From the Sundaland the single, plesiomorphic, widespread species *P. quadrimaculatus* may have reached recently the Indochinese mainland, where it, characteristically, does not go further east than Thailand.

The Philippines possess as many as 4 species, though the single rather plesiomorphic species *P. signatus* occurs on Palawan, the most westerly island of the Philippines, and may thus mark the way along which the genus introduced himself into the Philippines. The other Philippine species are fairly apomorphic or highly apomorphic species.

With altogether 4 species Sulawesi (Celebes) possesses a rich *Pericalus* fauna, though three species belong to the rather plesiomorphic *laetus*-group. Within that group, however, they are the perhaps rather plesiomorphic species. The fourth species, *P. picturatus*, is one of the most highly evolved species of the whole genus.

New Guinea has two apomorphic species, one widespread, the other apparently with a limited range, and New Britain has another apomorphic species closely related to one from New Guinea. In fact, *P. figuratus* from New Guinea is in some external characters the most highly evolved species of the whole genus.

Although the place of origin of the subgenus *Coeloprosoopus* is perhaps settled, the history of the different species-groups and subgroups must have been rather different, as may be seen from the phylogenetical and chorological evidence mentioned above in the text and in the different tables.

Tetrastigma-group. Both species of this apparently very plesiomorphic group originated presumably on Sundaland, where they still live today.

Quadrimaculatus-group. As mentioned above, the single species originated most probably on the former Sundaland and later spread to the Asian mainland.

Signatus-group. The two species of this group presumably originated also in Sundaland, from where one species (*P. signatus*) immigrated into the western Philippines and probably crossed WALLACE's line to the east, but did not intrude far into the Wallacea.

Laetus-group. The interpretation of the chorological aspects of this group is slightly more difficult. According to chorological evidence this is a true Wallacean lineage. Its more derived lineage (*gratus*-subgroup) actually lives only to the east of WALLACE's line on Sulawesi (Celebes), whereas *P. laetus*, the single species of the more plesiomorphic lineage (*laetus*-subgroup) occurs as well in Sulawesi as apparently also in eastern Borneo and thus, on the west of WALLACE's line. I think, however, that this is a rather young invader to the easternmost part of Sundaland, so the *laetus*- and *gratus*-lineages might have originated in the Wallacea.

Undatus-group. Certainly the *undatus*-group evolved in the Wallacea, in the western part of which the most plesiomorphic species still exist (*P. levifrons*), and some of the most derived species rather recently dispersed to the Papuan subregion. The *xanthopus*-subgroup, however, apparently dispersed to the west, crossed WALLACE's line, and is today probably no longer present to the east of this line. Perhaps by simple chorological evidence it is possible to track the way of this group into Sundaland, because different from *P. depressus* and *P. angusticollis* the less derived species *P. xanthopus* does not occur on the Asian mainland and is perhaps still present on Sulawesi (though by virtue of doubtful records that, however, could be due to its rarity there).

To conclude the distribution pattern in the subgenus *Coeloprosoopus*, most of the apomorphic species-

groups and species occur in the eastern and southeastern marginal areas of the common range, namely in the Wallacea and the Papuan subregion beyond the range of the nominate subgenus. The more plesiomorphic species-groups and species, on the other hand, concentrate in Malaysia and the Greater Sunda Islands, the previous Sundaland. However, the dispersal was not unidirectional in a simple west-to-east direction, but at least once (in the *xanthopus*-subgroup) Sundaland has been colonized from the Wallacea. Hence it becomes evident that, although the number of species is large on the former Sundaland, not this area, but rather the Wallacea and the Papuan subregion acted as generators of species and group diversity.

The distributional patterns show that WALLACE's line is indeed rather important as barrier to the dispersal of species, because only two species (*P. laetus* and *P. xanthopus*) probably occur on both sides of it, though even their occurrence is somewhat doubtful. Apparently this line has been likewise important as a barrier to the dispersal of species-groups and even subgenera.

Early origin of the genus *Pericalus*

Some ideas have been raised about the area where the genus *Pericalus* originated, but the question of the genus' original provenience has been not yet mentioned. The presumable origin of *Pericalus* in the Indo-chinese area or on former Sundaland might point to southern, Gondwanan relationships of the genus, because Sundaland at least, but also large parts of mainland southeast Asia and of Indochina have been geologically referred to as drifting terranes of southern origin that attached (perhaps successively) to the Asian mainland. Why they should not have brought with them parts of a former Gondwanan fauna that later dispersed on the mainland and over the insular belt? Although there is some reason to believe that *Pericalus* might have been such a drifting genus, any decision must perhaps await the full evaluation of the history of the relatives of *Pericalus*, especially the general history of the large genus *Coptodera* or the assemblage of genera summarized under this name. Although the South American species have been recently thoroughly revised and their biogeographical history has been elucidated (SHPELEY & BALL 1993), little is known so far about the many and rather diverse Oriental-Australian species of *Coptodera*. These would perhaps be a most rewarding object for anybody who wants to study a difficult and biogeographically important carabid group and who wants to test the hypotheses mentioned herein using the presumable adelphotaxon of *Pericalus*.

Conclusion

At present the biogeographical history of the genus *Pericalus* may be described as following on the basis of the distribution of the species and the species-groups and of phylogenetic evidence: The genus probably evolved in the Indochinese region (the area from Burma through Thailand to Laos). The earliest species were probably related to species of the recent subgenus *Pericalus* s. str. Later stocks of this group spread over the South Asian mainland to India in the west and Taiwan in the east, and in the south and southeast to the so-called Sundaland that was composed of recent southern Malaysia, southern Thailand, Sumatra, Java, and Borneo. Species of the nominate subgenus still live within this range and barely surpassed it - only to the Philippine island Palawan that belongs geographically rather to Borneo than to the Philippines proper. At any rate, they did not transgress WALLACE's line to the east.

The subgenus *Coeloprosope* presumably originated in Sundaland, where still many species persist, but only a part of the recent species-groups and subgroups occurs. As a consequence, many species still live on most of the Larger Sunda islands and in Malaysia. Only one species occurs on the mainland outside Malaysia but has reached only Thailand to the east. This is assumed a later invasion to the mainland from the original Sundaland. The Philippines and Sulawesi (combined to the Wallacea) on the eastern and southeastern margin of the generic range both possess a rich *Pericalus* fauna that is almost or completely composed of species of the subgenus *Coeloprosope* and includes mostly species of apomorphic species-groups or apomorphic species of the more plesiomorphic species-groups. The Wallacea has been thus colonized later and perhaps repeatedly by different *Coeloprosope* stocks coming from the west. New Guinea and New Britain possess fewer, but only highly evolved species which is evidence for a late colonization of the Australian region from the Wallacea. However, the Wallacea itself presumably produced a high species diversity and more important, at least one stock, on the other hand, recolonized Sundaland from the Wallacea.

The rather close relationships between many species demonstrates at least for the subgenus *Coeloprosopus* a fairly recent origin, diversification, and range spreading, part of which may have been occurred as late as in Pleistocene.

The distribution patterns within this genus clearly demonstrate the appropriate approach of the cladistic method to biogeographical questions, because in this genus the centre of origin and of species density, where still most plesiomorphic species occur, is surrounded at the east and southeast by marginal areas of high apomorphy and at the same time of high morphological diversity. For generating of biogeographical hypotheses it would be therefore difficult to employ the unweighted methods of DARLINGTON (1971) at least in the genus *Pericalus*.

Acknowledgements

My thanks are due to the following curators for the kind loan of types or specimens from their collections: Dr. M. BRANCUCCI (Basel), Dr. T. DEUVE (Paris), Dr. F. HIEKE (Berlin), Mr. S. HINE (London), Dr. L. HOBERLANDT (Praha), Dr. J. JELINEK (Praha), Dr. R. KRAUSE (Dresden), Dr. W. SCHAWALLER (Stuttgart), Dr. G. SCHERER (München), Dr. H. SCHÖNMANN (Wien), and Prof. S. L. STRANEO (Milano).

I also thank Mr. A. RIEDEL (München) for presenting to my disposal many interesting specimens he collected in different countries, Mr. M. HIERMEIER (München) for leaning me some specimens from Celebes, and Dr. M. BALKENOHL (Denzlingen) for sorting out of important *Pericalus* specimens in the museums of Basel and Paris.

I am also indebted to Prof. Dr. G. E. Ball (Edmonton) for his very valuable comments especially on the biogeographical part.

Literature

- ANDREWES, H. E. 1919: On the types of Oriental Carabidae in the British Museum and in the Hope Department of the Oxford University Museum. - Trans. Ent. Soc. London **52**, 119-217.
- 1926: Papers on Oriental Carabidae XVIII. - Ann. Mag. Nat. Hist. Ser 9., **18**, 273-290.
- 1927: Papers on Oriental Carabidae XIX. - Ann. Mag. Nat. Hist. Ser 9., **19**, 97-111.
- BALL, G. E. 1975: Pericaline Lebiini: notes on classification, a synopsis of the New World genera, and a revision of the genus *Phloeoxena* Chaudoir (Coleoptera: Carabidae). - Quaest. Entomol. **11**, 143-242.
- BASILEWSKY, P. 1984: Essai d'une classification supragénérique des Carabides Lébiens d'Afrique et de Madagascar (Coleoptera: Carabidae: Lebiinae). - Rev. Zool. Afr. **98**, 525-559.
- BRUNDIN, L. 1966: Transantarctic relationships and their significance, as evidenced by chironomid midges, with a monograph of the subfamilies Podonominae and Aphroteniinae and the austral Heptagyinae. - K. svenska Vetensk. Akad. Handl. **11**, 1-472.
- CASTELNAU, F. L. de. 1832: Mémoire sur cinquante espèces nouvelles ou peu connues d'insectes. - Ann. Soc. Ent. Fr. **1**, 386-415.
- CHAUDOIR, M. de 1842: Description de quelques genres nouveaux de la famille des Carabiques. - Bull. Soc. Nat. Mosc. **15**, 832-857.
- 1848: Mémoire sur la famille des Carabiques. I. - Bull. Soc. Nat. Mosc. **21**, 3-134.
- 1861: Beitrag zur Kenntnis einiger Carabicingen-Gattungen. - Berl. Ent. Z. **5**, 116-131.
- 1869: Mémoire sur les Thyroptérides. - Ann. ent. Belg. **12**, 113-162.
- CSIKI, E. 1932: Coleopterorum Catalogus. Pars 124. Carabidae III, Harpalinae VII - W. Junk, Berlin.
- DARLINGTON, P. J. Jr. 1968: The Carabid beetles of New Guinea. Part III. Harpalinae continued. Perigonini to Pseudomorphini. - Bull. Mus. Comp. Zool. **137**, 1-253.
- 1971: The Carabid beetles of New Guinea. Part IV. General considerations, analysis and history of the fauna. Taxonomic supplement. - Bull. Mus. Comp. Zool. **142**, 129-337.
- DUPUIS, P. 1913: P. H. Sauter's Formosa-Ausbeute. Carabidae. - Ann. Soc. Ent. Belg. **57**, 81-87.
- ERWIN, T. L. 1979. Thoughts on the evolutionary history of ground beetles: hypotheses generated from comparative faunal analyses of lowland forest sites in temperate and tropical regions. In: ERWIN, T. L., G. E. BALL, D. R. WHITEHEAD, and A. T. HALPERN (Eds): Carabid Beetles: Their Evolution, Natural History and Classification, 539-592. - W. Junk, The Hague.
- HELLER, K. M. 1916: Philippinische Käfer, gesammelt von Prof. C. FULLER-BAKER, Los Banos. - Dt. ent. Z. 1916, 269-.
- HENNIG, W. 1966: Phylogenetic Systematics. - University of Illinois Press, Urbana.
- JEDLICKA, A. 1936: *Pericalus undatus* v. *signatus* var. nov. - Ann. Soc. ent. Praha **33**, 25.

- 1953: Neue Carabiden aus der chinesischen Provinz Fukien. - Ent. Bl. **49**, 141-147.
-- 1963: Monographie der Truncatipennen aus Ostasien. Lebiinae - Odacanthinae - Brachyninae (Coleoptera, Carabidae). - Ent. Abh. Mus. Tierk. Dresden **28**, 269-579.
LACORDAIRE, T. 1854: Histoire naturelle des Insectes. Genera des Coléoptères I. - Paris.
LOUWERENS, C. J. 1964: An annotated list of the Carabidae, chiefly collected in East Borneo by Dr. Eric Mjöberg with descriptions of new species. - Ent. Tijds. **85**, 171-189.
-- 1969: Carabidae (Col.) collected by the Noona Dan Expedition in the Bismarck Islands. - Ent. Medd. **37**, 251-372.
MACLEAY, W. S. 1825: Annulosa Javanica I, 1-50. - London.
SCHAUFUSS, L. W. 1887: Beitrag zur Fauna der Niederländischen Besitzungen auf den Sunda-Inseln. II. - Hor. Soc. Ent. Ross. **21**, 103-147.
SCHAUM, H. 1860: Beiträge zur Kenntnis einiger Laufkäfer-Gattungen. - Berl. Ent. Z. **4**, 181-203.
-- 1861: In CHAUDOIR, M. de. Beitrag zur Kenntnis einiger Carabiden-Gattungen. - Berl. Ent. Z. **5**, 124-125.
SCHMIDT-GÖBEL, H. 1846: Faunula Coleopterorum Birmamiae, 1-94.
SHPELEY, D. & G. E. BALL 1993: Classification, reconstructed phylogeny and geographical history of the New World species of *Coptodera* Dejean (Coleoptera: Carabidae: Lebiini). - Proc. Ent. Soc. Ontario **124**, 1-182.

Alphabetical checklist of the species of the subgenus *Coeloprotopus* CHAUDOIR

synonyms indented

<i>angusticollis</i> , sp. n.	p. 34	<i>magnus</i> , sp. n.	p. 26
<i>atricornis</i> , sp. n.	p. 29	<i>philippinus</i> HELLER	p. 40
<i>cuprascens</i> , sp. n.	p. 37	<i>picturatus</i> CHAUDOIR	p. 41
<i>depressus</i> ANDREWES	p. 33	<i>spiniger</i> ANDREWES	
<i>figuratus</i> CHAUDOIR	p. 43	<i>quadrinaculatus</i> (MACLEAY)	p. 19
<i>gratus</i> SCHAUM	p. 25	<i>quadrisignatus</i> CASTELNAU	
<i>klapperichi</i> JEDLICKA	p. 36	<i>robustus</i> , sp. n.	p. 21
<i>macrostictus</i> LOUWERENS		<i>signatus</i> JEDLICKA	p. 22
<i>laetus</i> SCHAUM	p. 23	<i>tetrastigma</i> CHAUDOIR	p. 28
<i>adonis</i> SCHAUFUSS		<i>undatus</i> CHAUDOIR	p. 38
<i>levifrons</i> HELLER	p. 30	<i>xanthopus</i> SCHAUM	p. 31

Author's Address

Dr. Martin BAEHR
Zoologische Staatssammlung
Münchhausenstr. 21
D-81247 München
Germany

ZOBODAT - www.zobodat.at

Zoologisch-Botanische Datenbank/Zoological-Botanical Database

Digitale Literatur/Digital Literature

Zeitschrift/Journal: [Mitteilungen der Münchner Entomologischen Gesellschaft](#)

Jahr/Year: 1994

Band/Volume: [084](#)

Autor(en)/Author(s): Baehr Martin

Artikel/Article: [Revision of the subgenus *Coeloprosopus* Chaudoir of the ground beetle genus *Pericalus* Macleay. Taxonomy, phylogeny, zoogeography \(Col. Carabidae, Lebiinae\). 13-58](#)