

Stuttgarter Beiträge zur Naturkunde

Serie A (Biologie)

Herausgeber:

Staatliches Museum für Naturkunde, Rosenstein 1, D-70191 Stuttgart

Stuttgarter Beitr. Naturk.	Ser. A	Nr. 624	51 S.	Stuttgart, 20. 7. 2001
----------------------------	--------	---------	-------	------------------------

Morphological and Phylogenetical Studies in the Isopoda (Crustacea). Part 4: The Pleopods and Uropods in the Asellota

By Friedhelm Erhard, Stuttgart

With 29 figures

Summary

The skeleton and musculature of the pleopods I–III and the uropods in basal species of the isopodan group Asellota are described. As far as possible, functional interpretations on the skeletal and muscular systems are proposed. The attempt is made to reconstruct groundpattern characters of the asellotan pleopods and uropods. The comparison with corresponding morphological data in the taxa Phreatoicidea and Oniscidea indicates character transformations inside the Isopoda. First judgments on the polarity assessment of characters are discussed.

Zusammenfassung

Das Skelet und die Muskulatur der Pleopoden und Uropoden von basalen Arten der Isopodengruppe Asellota werden dokumentiert. Soweit dies möglich ist, werden Hypothesen zur Funktion des Skelet-Muskel-Systems vorgeschlagen. Es wird der Versuch unternommen, Grundplan-Merkmale der Pleopoden und Uropoden der Asellota zu rekonstruieren. Der Vergleich mit entsprechenden morphologischen Daten der Taxa Phreatoicidea und Oniscidea weist auf Merkmalstransformationen innerhalb der Isopoda hin. Erste Einschätzungen zur Lesrichtung der Merkmale werden diskutiert.

Contents

1. Introduction	2
2. Material, methods and abbreviations	3
2.1. Material	3
2.2. Methods	3
2.3. Abbreviations	4
3. Previous investigations and terminology	5
4. Pleopods	5
4.1. Pleopods I	5
4.1.1. Asellotan species	5
4.1.1.1. Skeleton	5
4.1.1.2. Musculature	8
4.1.2. Comparison	9

4.2. Pleopods II	11
4.2.1. Asellotan species	11
4.2.1.1. Skeleton	11
4.2.1.2. Musculature	14
4.2.2. Comparison	19
4.3. Pleopods III	26
4.3.1. Asellotan species	26
4.3.1.1. Skeleton	26
4.3.1.2. Musculature	28
4.3.2. Comparison	30
4.4. Comparison of characters concerning all pleopods	31
4.4.1. Skeleton	31
4.4.2. Musculature	35
5. Uropods	38
5.1. Asellotan species	38
5.1.1. Skeleton	38
5.1.2. Musculature	39
5.2. Comparison	40
6. Conclusions	43
6.1. Groundpattern characters	43
6.1.1. Pleopods I	43
6.1.2. Skeleton of the pleopods II	44
6.1.3. Musculature of the pleopods II	44
6.1.4. Pleopods III	45
6.1.5. Skeleton of the pleopods I–V	45
6.1.6. Musculature of the pleopods I–V	46
6.1.7. Skeleton of the uropods	47
6.1.8. Musculature of the uropods	47
6.2. Apomorphies	48
6.2.1. Phreatoicidea	48
6.2.2. Oniscidea / Asellota	48
6.2.3. Oniscidea	49
6.2.4. Asellota	49
6.2.5. Characters of uncertain polarity	50
7. Acknowledgments	50
8. References	50

1. Introduction

Within the first part of the series “Morphological and Phylogenetical Studies in the Isopoda” (ERHARD 1998a) the necessity for detailed descriptions of anatomical characters was emphasized which might be useful to clarify existing inconsistencies in reconstructing the phylogenetic relationships between the main groups of the taxon Isopoda. As a contribution towards a reliable phylogenetical system, investigations on the internal anatomy of isopods are carried out within the scope of the mentioned publication series. The first and second part (ERHARD 1998a, 1999) deal with the pleonal anatomy in the Phreatoicidea. Part 3 (ERHARD 2001) treat the anatomy of the pleon trunk in basal asellotan species while the present paper describes the pleonal limb morphology in the Asellota. The documented characters of the investigated asellotan species are compared with corresponding data of the Phreatoicidea and Oniscidea (ERHARD 1995, 1996, 1997, 1998a, b, 1999). The attempt is made to reconstruct groundpattern characters of the asellotan pleopods and uropods.

A following fifth part of the series will include a final analysis of the phylogenetic-systematic relationships between the three isopodan taxa Phreatoicidea, Asellota and Oniscidea.

2. Material, methods and abbreviations

2.1. Material

Tanaidacea

Apseudomorpha

Apseudes latreilii (M. Edwards, 1828), W-France, Brittany, Roscoff.

Isopoda

Asellota

Stenasellus costai Lanza, Chelazzi & Messina, 1970, Somalia, El Ali (ex coll. MESSANA nr. 322)

Asellus aquaticus (Linnaeus, 1758), S-Germany, Baden-Württemberg, Tübingen
Vermectias nelladanae Just & Poore, 1992, Australia, Tasmania, Macquarie Island, Green Gorge (ex NMV J21593).

Phreatoicidea

Metaphreatoicus australis (Chilton, 1891), Australia, New South Wales, Mt. Kosciusko (SMNS 14016, 14048)

Colubotelson joyneri searlei Nicholls, 1944, Australia, E-Victoria, Mt. Baw Baw (SMNS 14019)

Onchotelson brevicaudatus (Smith, 1909), Tasmania, Great Lake, southern bank (SMNS 14047)

Mesacanthotelson tasmaniae (Thomson, 1894), Tasmania, Great Lake, southern bank (SMNS 14047)

Paramphisopus palustris (Glauert, 1924), Australia, Western Australia, Lake Monger (SMNS 14119; ex AM P44487)

Phreatoicopsis terricola Spencer & Hall, 1896, Australia, Victoria, The Grampians (SMNS 14118; ex NMV J44869)

Nichollsia kashiensis Chopra & Tiwari, 1950, India, Banaras (SMNS 12149)

Mesamphisopus capensis Barnard, 1914, South Africa, Southern Cape, Zonder End Mountains (SMNS 15517; ex SAM A6052).

Calabozoidea

Calabozoa pellucida Van Lieshout, 1983, Venezuela, Calabozo (ex coll. WÄGELE).

Oniscidea

Ligia oceanica (Linnaeus, 1767), W-France, Brittany, Roscoff

Tylos ponticus Grebnitzky, 1874, Greece, island of Crete, E Sitia and island of Astipalea, Maltesana (SMNS 1242, 1549)

Mesoniscus alpicola (Heller, 1858), S-Germany, Bavaria, 6 km W Berchtesgaden

Titanethes albus Schiödte, 1849, Slovenia, 30 km S Ljubljana, Videm-Popeč, water cave (SMNS 5080, 5253)

Actaecia bipleuria Lewis & Green, 1994, Tasmania, W Tamar River, W Greens Beach

Oniscus asellus Linnaeus, 1758, S-Germany, Baden-Württemberg, Tübingen.

Valvifera

Saduria entomon (Linnaeus, 1758), Finland, Tvärminne (SMNS 4205).

2.2. Methods

Skeleton and musculature of the pleopods and uropods were reconstructed by manual micropreparation of fuchsine-stained material under the stereomicroscope and by the use of his-

tological serial sections examined under the light microscope. The thickness of the histological sections was 7 µm, they were stained in haematoxylin-eosin and azan. The skeleton was also investigated after maceration in diethylenetriamine (KRAUTER 1980) and staining in chlorazol-black (CANNON 1937).

The morphological data on the isopodan pleopods and uropods are interpreted, if this is possible at the present state of knowledge, strictly according to the method of phylogenetic systematics proposed by HENNIG (1966).

The morphological study within the paper in hand treats mainly the skeleton and musculature of the pleopods I–III and the uropods of the asellotan species *Stenasellus costai* (Stenasellidae) and *Asellus aquaticus* (Asellidae). These species of the group Aselloidea were selected because this group might represent the most basal superfamily of the Asellota (cf. KUSSAKIN 1973, WILSON 1987 and WÄGELE 1989). Therefore, it seems to be quite possible that the Aselloidea might still have retained numerous plesiomorphous characters in relation to the asellotan groundpattern.

After the description of one anatomical complex, characters are discussed by in- and outgroup comparisons and attempts are made to reconstruct groundpattern characters of the asellotan pleopods and uropods. In this connection, *Vermectius nelladanae*, a tiny representative of the primitive asellotan incertae sedis family Vermectiadiidae (cf. JUST & POORE 1992), is considered in a special way. The states of outgroup characters are determined mainly by anatomical investigations of the tanaidacean species *Apsendus latreillii*. Following recently published studies on the phylogeny of the Peracarida (TABACARU & DANIELOPOL 1999, KOBUSCH 1999), the taxon Tanaidacea represents the sistergroup of the Isopoda.

The results were gathered chiefly from male specimens. It is emphasized if females were considered. Within the graphical reconstructions membranes are indicated by bold dotting.

2.3. Abbreviations

<i>A</i>	Point of articulation
<i>AM</i>	Australian Museum, Sydney, Australia
<i>Ap</i>	Apophysis
<i>Chan</i>	Anterior channel of appendix masculina
<i>En</i>	Pleopod endopodite
<i>EnDA</i>	Distal article of pleopod endopodite
<i>EnPA</i>	Proximal article of pleopod endopodite
<i>Ex</i>	Pleopod exopodite
<i>ExDA</i>	Distal article of pleopod exopodite
<i>ExPA</i>	Proximal article of pleopod exopodite
<i>ExPLob</i>	Proximal Lobe of pleopod exopodite
<i>HSet</i>	Hooked or other coupling setae
<i>IOEn</i>	Insertion opening of pleopod endopodite
<i>IOPr</i>	Insertion opening of pleopod protopodite
<i>IOU</i>	Insertion opening of uropod
<i>M</i>	Muscle
<i>Mb</i>	Membrane
<i>Mm</i>	Muscles
<i>NMV</i>	National Museum of Victoria, Australia
<i>PlSt</i>	Pleon sternite
<i>pPrAp</i>	Posterior apophysis of pleopod protopodite
<i>Pr</i>	Pleopod protopodite
<i>Prcy</i>	Processus cylindrifformis (after MAERCKS 1930: 412)
<i>Proj</i>	Cuticular hooklike projection
<i>PtSt</i>	Pleotelsonic sternite
<i>PtT</i>	Pleotelsonic tergite
<i>SAM</i>	South African Museum Cape Town, South Africa
<i>Scl</i>	Sclerite
<i>SMNS</i>	Staatliches Museum für Naturkunde Stuttgart, Germany
<i>Spur</i>	Medial spur or distal article of male pleopod endopodite II in <i>Asellus</i>
<i>StPr</i>	Sternal processus

<i>Tube</i>	Sperm tube
<i>UAp</i>	Apophysis of uropod protopodite
<i>UEn</i>	Uropod endopodite
<i>UEx</i>	Uropod exopodite
<i>UPr</i>	Uropod protopodite.

In the figures numerous abbreviations are completed by *roman numbers* which apply to corresponding pereion or pleon segments.

3. Previous investigations and terminology

An overview on previous investigations on the pleonal skeleton and musculature in the Asellota and further isopodan and peracaridan taxa is given within the first and third part of the publication series in hand on isopod morphology and phylogenetics (ERHARD 1998a: 5, 2001).

The results of the present investigation on the pleopodal skeleton and musculature of the Asellota will be compared here with literature data of comparative-anatomical studies on the Oniscidea and Phreatoicoidea carried out by ERHARD (1995, 1996, 1997, 1998b, 1999). Therefore, the consecutive numbering of the muscles refers to the nomenclature used in the above cited publications. Gaps in the numbering indicate muscles which are only present in subordinate oniscidean groups (cf. ERHARD 1995, 1996, 1997) but not within the groundpatterns of the Oniscidea and Phreatoicoidea or in the investigated asellotan species.

For the purpose of consistency, the terms of skeletal structures, their abbreviations and their spellings were adopted from ERHARD (1995, 1996, 1997, 1998a, b, 1999).

4. Pleopods

4.1. Pleopods I

4.1.1. Asellotan species (figs. 1–4)

4.1.1.1. Skeleton

In male specimens of *Stenasellus costai* and *Asellus aquaticus* the pleopod I is uniramous and consists of a protopodite and a single exopodite joint, the endopodite is completely reduced. The pleopods I in both species are clearly smaller than the pleopods III–V and they are covering the small second pleopods (cf. ERHARD 2001: figs. 1, 4, 5, 8, 9). In *Stenasellus costai* the point of insertion of the male pleopod I is situated at the back margin of the well-developed pleon sternite I while the pleopod II is inserted at the front margin of the pleon sternite II. In *Asellus aquaticus* the pleopods I and II are also situated close together on account of the shortness of the pleonites I and II (cf. ERHARD 2001: figs. 8–9). This spacial arrangement indicates a slight coadaptation between both limbs, namely the covering of the pleopods II by the pleopods I. For that purpose the posteriodistal walls of the pleopod exopodite I in *Stenasellus* and *Asellus* are depressed as in a spoon. Additionally, the male pleopod exopodite I of *Asellus aquaticus* shows a specific lateral incision with prominent sclerotized margins that probably might serve for special copulatory tasks (figs. 3–4). In females of *Stenasellus* and *Asellus* the pleopods I are completely reduced.

The male pleopod protopodite I of *Stenasellus costai* and *Asellus aquaticus* is formed by a single joint. Between protopodite I and pleon sternite I medioposterior

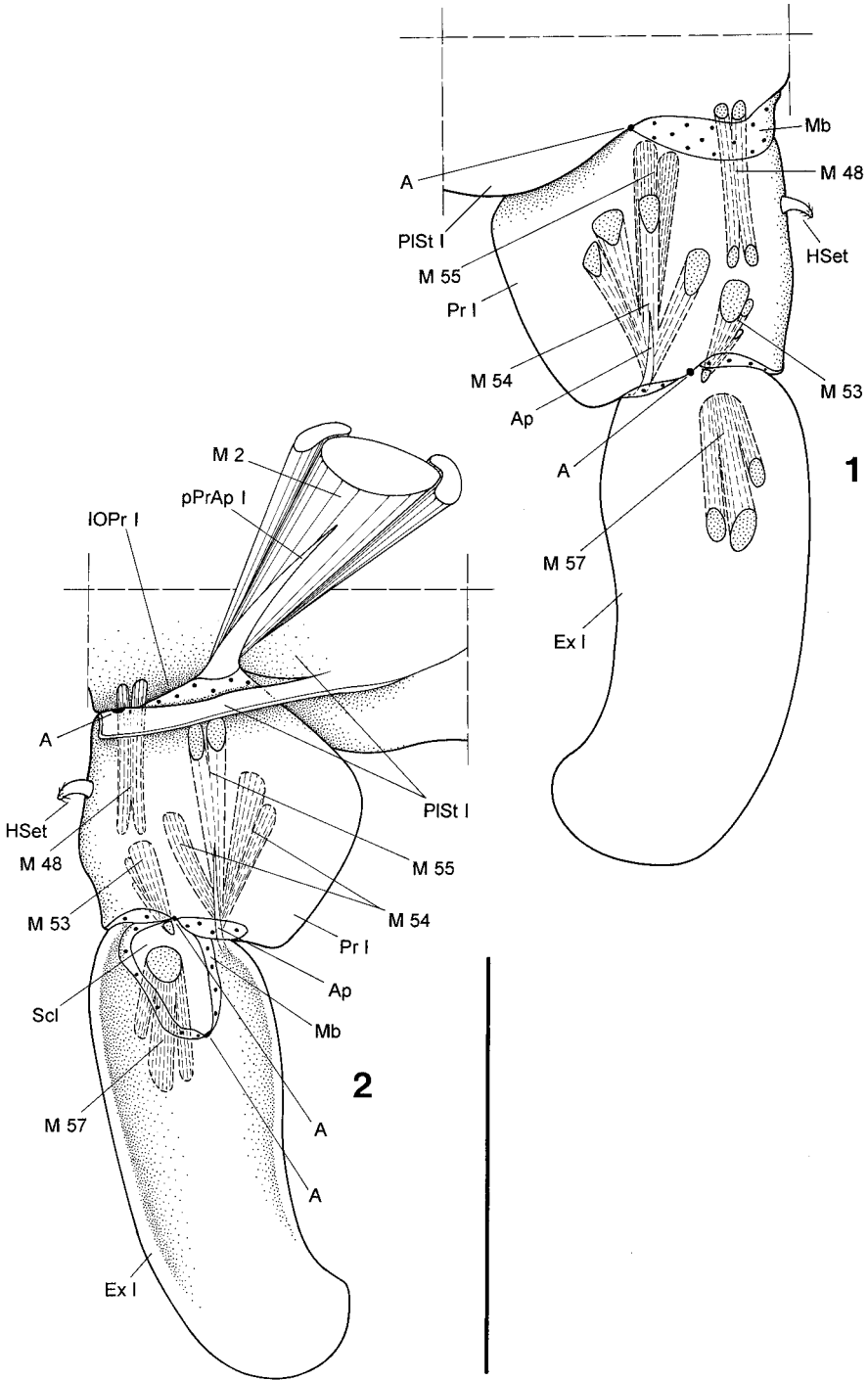

Figs. 1-2. *Stenasellus costai*, ♂, right pleopod I. - 1. Anterior view; - 2. posterior view. - Scale: 1 mm.

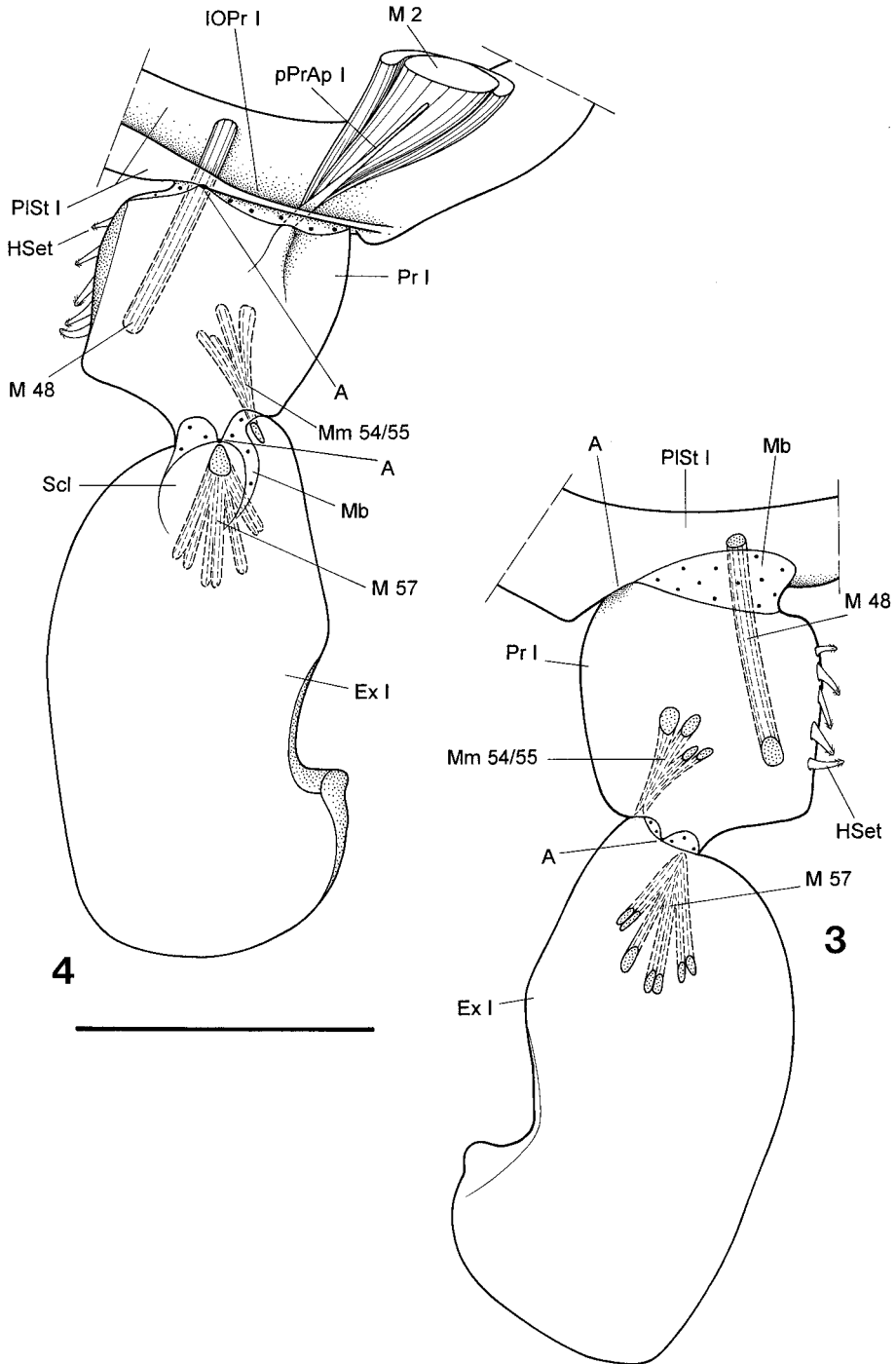

Figs. 3-4. *Asellus aquaticus*, ♂, right pleopod I. - 1. Anterior view; - 2. posterior view. - Scale: 0,5 mm.

and lateroanterior articular points are developed. Thus, the pleopods I are able to perform movements in anterior and posterior direction. Between the pleon sternite I and the medioanterior wall of the pleopod protopodite I a conspicuous membrane is developed. At the basal posterior wall of the protopodite I a large apophysis as point of insertion for the tergal protopodite I-remotor M2 is present (figs. 2, 4: pPrAp I).

In *Asellus aquaticus* the medial walls of the pleopod protopodites I are connected with each other by five fingerlike spines equipped with numerous small hooks at their tips serving as coupling facilities to unite both pleopods I. In *Stenasellus costai* one comparable spine is developed at the medial base of each pleopod protopodite I (figs. 1–4: HSet). Conspicuous medial lobes as bases for the coupling spines do not exist in both species. Furthermore, lateral epipodites on the pleopod protopodite I are missing.

In *Stenasellus costai* and *Asellus aquaticus* the pleopod protopodite I and the exopodite I have a dicondylic articulation (figs. 1–4). The articular points are located anteriorly and posteriorly. At the posterior side the contact between protopodite I and exopodite I is formed by a subtriangular sclerite (figs. 2, 4: Scl) which is surrounded by articular membrane. This kind of articulation is corresponding to the situation present in all pleopods of phreatoicidean species (cf. ERHARD 1999: 5). However, the intermediate sclerite in *Stenasellus costai* and especially in *Asellus aquaticus* is much more incorporated into the posterior exopodite wall than it is the case in the Phreatoicidea. The lateral basis of the pleopod exopodite I in *Stenasellus* and *Asellus* is equipped with an apophysis as point of insertion for the lateral exopodite locomotors Mm 54/55 (figs. 1–2: Ap).

4.1.1.2. Musculature

M 47: The pleopod endopodite I-locomotor present in the oniscidean and phreatoicidean groundpatterns (cf. ERHARD 1995, 1999) is missing in the Asellota on account of the complete reduction of the endopodite I.

M 48: Intrinsic promotor of the pleopod protopodite I. Arises medially on the anterior pleon sternite I, passes the anterior membrane between pleon sternite I and protopodite I and is inserted medially on the anterior wall of pleopod protopodite I. Composed of one bundle which is divided at its points of attachment in *Stenasellus costai*. Homologous to M 48 of the Phreatoicidea (cf. ERHARD 1999: 8) and the Oniscidea (cf. ERHARD 1995, 1996, 1997). Synonymous with “m₁i” of *Asellus aquaticus* in MAERCKS (1930: fig. 15).

M 49: The pleopod endopodite I locomotor present in male species of the Oniscidea-Crinocheta (ERHARD 1995, 1997) is missing in the Asellota as well as in the Phreatoicidea (cf. ERHARD 1999). The presence of M 49 might represent an autapomorphy of the Oniscidea-Crinocheta (cf. ERHARD 1997, 1998b).

M 50: The muscle described in the Oniscidea-Orthogonopoda (= Mesoniscidae + Synocheta + Crinocheta, cf. ERHARD 1998b) might be homologous to M 56 of the oniscid *Ligia oceanica* (cf. ERHARD 1995: 38) and of the Phreatoicidea (cf. ERHARD 1999: 8). M 56 could not be shown in the investigated asellotan species.

M 51: The muscle present in the Phreatoicidea (cf. ERHARD 1999: 8) and in the oniscid *Oniscus asellus* (cf. ERHARD 1995: 36) could not be shown in the investigated asellotan species.

M 52: Up to now only described as intrinsic levator of the pleopod protopodite I in the oniscid *Ligia oceanica* (ERHARD 1995: 38). Presumably homologous to the endopodite I locomotor M 47 of the Phreatoicidea (cf. ERHARD 1999: 7) and the Oniscidea-Crinocheta (cf. ERHARD 1995, 1996, 1997) which is missing in the Asellota.

M 53: Moves the pleopod exopodite I in medial direction. In *Stenasellus costai* the medial exopodite locomotor arises anteriomedially within the distal part of protopodite I and is inserted on the medial exopodite I-basis. Composed of about three bundles. Homologous to M 53 of the Phreatoicidea (ERHARD 1999: 8) and of the oniscid *Ligia oceanica* (cf. ERHARD 1995: 38). M 53 could not be shown in *Asellus aquaticus*.

Mm 54/55: The lateral pleopod exopodite I locomotors move the exopodite I in lateral direction. In *Stenasellus costai* Mm 54/55 are composed of two distinct muscle groups: M 54 arises with about four bundles on the anterior wall of the pleopod protopodite I whereas M 55 is originating with two bundles on the posterior protopodite wall. Both muscle groups are inserted on the lateral exopodite I apophysis (figs. 1–2). This spatial arrangement is exactly identical with the condition of the oniscid *Ligia oceanica* (ERHARD 1995: 38) wherefore the muscle components, presumably, might be homologous. In *Asellus aquaticus*, however, the spatial difference concerning the points of origin could not be observed. Mm 54/55 of *Asellus* consist only of about four bundles which all are arising on the anterior protopodite wall (figs. 3–4). Mm 54/55 of the investigated asellotan species are homologous to Mm 54/55 of the Phreatoicidea (ERHARD 1999: 8) and the oniscid *Ligia oceanica* (ERHARD 1995: 38). Synonymous with “m_{2a}” of *Asellus aquaticus* in MAERCKS (1930: fig. 15).

M 56: The medial pleopod exopodite I-locomotor present in the Phreatoicidea (ERHARD 1999: 8) and in the Oniscidea (ERHARD 1995: 38) could not be shown in the investigated asellotan species.

M 57: Locomotor of the pleopod exopodite I. Arises on the posterior articular sclerite between protopodite I and exopodite I and is inserted on the anterior wall of the exopodite I. Composed of three to seven bundles. Homologous to M 57 of the Phreatoicidea (cf. ERHARD 1999: 8) and of the oniscid *Ligia oceanica* (cf. ERHARD 1995: 39). Synonymous with “m_{2i}” of *Asellus aquaticus* in MAERCKS (1930: fig. 15).

Mm 115–116: The interarticular protopodite I-muscles M 115 and M 116 are present in the Phreatoicidea (cf. ERHARD 1999: 8) but could not be shown in the Oniscidea (cf. ERHARD 1995, 1996, 1997) and in the investigated asellotan species.

M 117: The intrinsic pleopod endopodite I-muscle M 117 existent in the Phreatoicidea (cf. ERHARD 1999: 9) could not be shown in the pleopods I of the Oniscidea (cf. ERHARD 1995, 1996, 1997) and the investigated asellotan species.

4.1.2. Comparison (figs. 5–6)

– Reduction of the male pleopod endopodite I

In *Stenasellus*, *Asellus* and *Vermectias* as well as in the groundpattern of the Asellota the pleopod endopodite I including its musculature (M 47) is completely reduced (cf. WILSON 1987: 261, WÄGELE 1989: 60, BRUSCA & WILSON 1991: 35). The identification of the retained ramus as an exopodite is unequivocal on account of its typical equipment of medial and lateral exopodite locomotors which are still present in *Asellus* and *Stenasellus* and also in the pleopods I of the Phreatoicidea

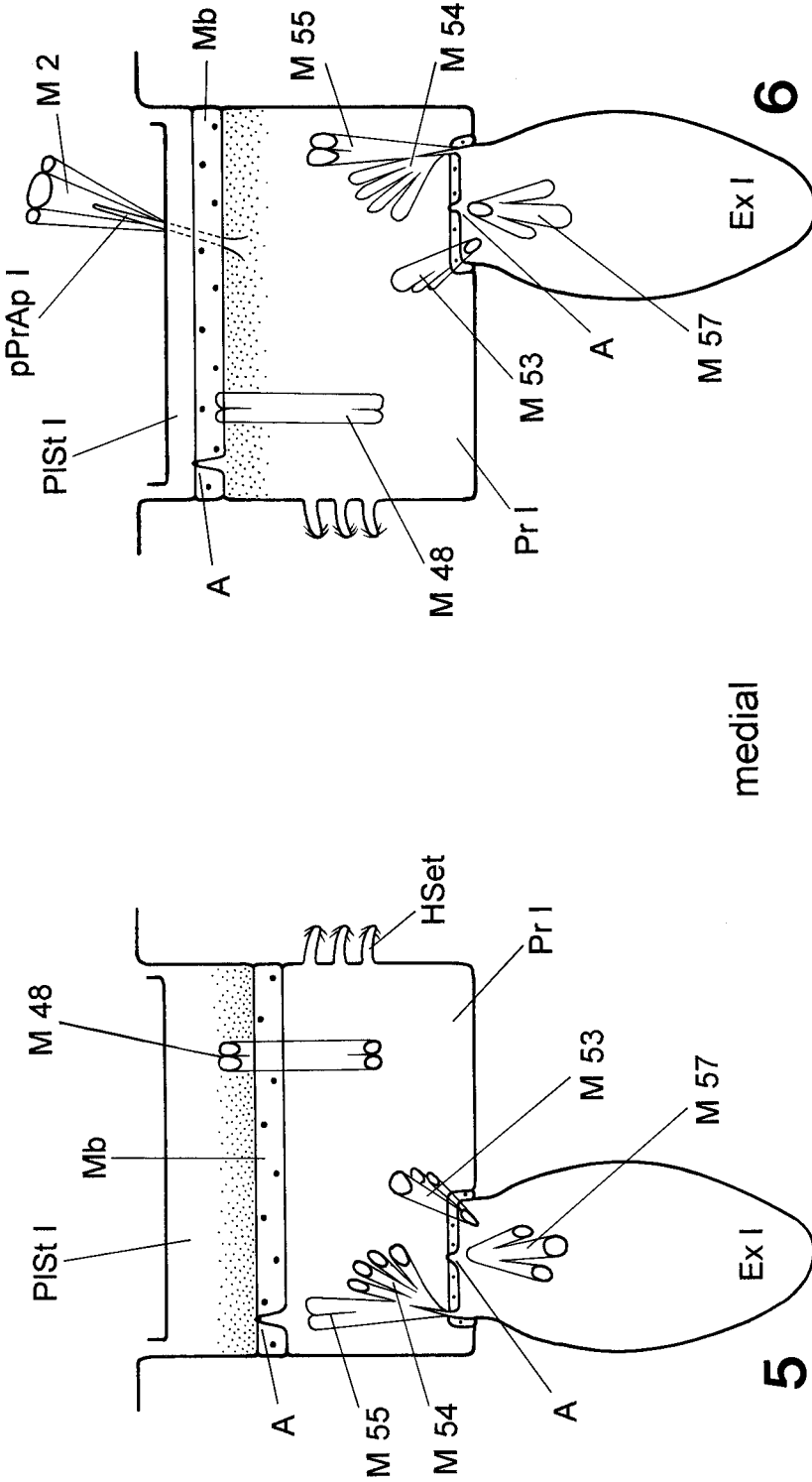

Figs. 5-6. Diagrams of the skeleton and musculature of the male pleopods I within the hypothetical groundpattern of the Ascellota (compare with corresponding diagrams of the Phreatoidea and Oniscidea in ERHARD 1999; figs. 4-7). Areas of former proximal protopodite articles indicated by *compact dotting*, membranes by *bold single dots*. - 5. Anterior view; - 6. posterior view.

and Oniscidea (cf. chapt. 4.1.1.2.; ERHARD 1995, 1996, 1997, 1999). The lack of the male pleopod endopodite I and its locomotor M 47 represents an autapomorphy of the Asellota because the male pleopods I in the isopodan groundpattern is biramous as retained for example in *Tainisopus* (cf. WILSON & PONDER 1992), *Calabozoa* (cf. Van LIESHOUT 1983), the Phreatoicidea and Oniscidea (cf. ERHARD 1995, 1999).

– Reduction of the female pleopod I

According to WÄGELE (1989) and BRUSCA & WILSON (1991) the complete reduction of the female pleopod I in the Asellota represents an autapomorphy of the group. Within the isopodan groundpattern biramous female pleopods I are present.

4.2. Pleopods II

4.2.1. Asellotan species (figs. 7–10)

4.2.1.1. Skeleton

The male pleopods II of *Stenasellus costai* and *Asellus aquaticus* are composed of a protopodite, an exo- and an endopodite. In females the pleopod endopodites II are completely reduced and the exopodites II are uniarticulate. The male pleopods II in both species are clearly smaller than the pleopods III–V and they are covered by the small pleopods I (cf. chapt. 4.1.1.1.; ERHARD 2001: figs. 4–5).

The male pleopod protopodite II of *Stenasellus costai* and *Asellus aquaticus* is formed by a single article. Between protopodite II and pleon sternite II medioposterior and lateroanterior articular points are developed. Thus the pleopods II are able to perform movements in anterior and posterior direction. Between the pleon sternite II and the medioanterior wall of the protopodite II a conspicuous membrane is developed. At the basal posterior wall of the protopodite II a large apophysis as point of insertion for the tergal protopodite II-remotor M 6 is present (figs. 8, 10: pPrAp II). At the medial wall of the pleopod protopodite II neither medial lobes nor distally hooked coupling spines do occur in *Asellus* and *Stenasellus*. Furthermore, lateral epipodites on the pleopod protopodites II are missing.

In *Stenasellus costai* and *Asellus aquaticus* the male pleopod exopodite II is formed by two separate articles (figs. 7–10: ExPA II, ExDA II). The pleopod protopodite II and the basal exopodite II-joints have a dicondylic articulation. The articular points are located anteriorly and posteriorly. Between the basal and the distal exopodite II-articles no conspicuous articular points could be shown, however, an intersegmental membrane occurs which is stretched over the entire exopodite width. In *Stenasellus* and *Asellus* the exopodite II-basis is equipped with a lateral and a medial apophysis as points of attachment for the medial and lateral exopodite II-locomotors Mm 63 and 65/66.

The distal exopodite II-joints of *Stenasellus costai* and *Asellus aquaticus* show on their posterior walls elevated and hooklike projections (figs. 8, 10: Proj) which might serve as coupling structures that allow the exopodites to grasp the endopodites during the copulatory act. In *Asellus* the exopodite II couples with the mediobasal spur (= distal article) of the endopodite II during copulation. The exact interlocking

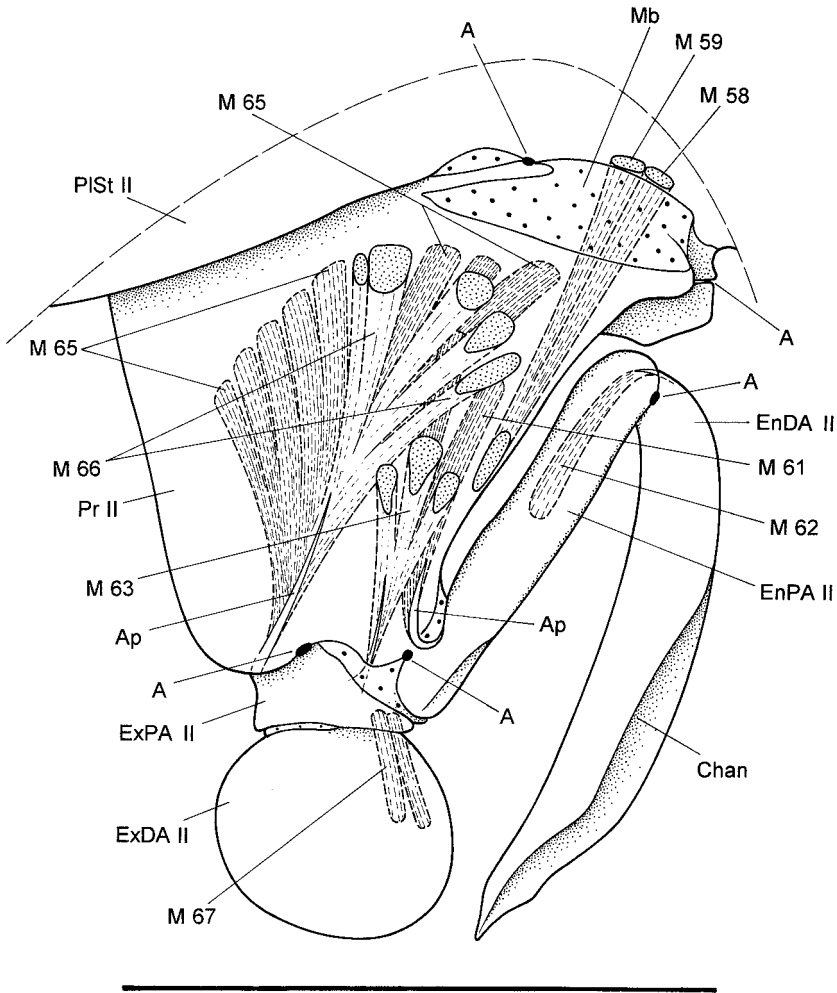

Fig. 7. *Stenasellus costai*, ♂, right pleopod II in anterior view. – Scale: 1 mm.

mechanism and the copulatory act in *Asellus aquaticus* are described in detail by MAERCKS (1930).

The male pleopod endopodite II of *Stenasellus costai* is composed of two separate articles. In the resting position the slender and elongate proximal endopodite joint is situated close to the medial protopodite wall and the distal joint (= appendix masculina) articulates at acute angles to the proximal joint (figs. 7–8: EnPA II, EnDA II). Between the proximal and the distal male pleopod endopodite II-article a dicondylic articulation is developed. It is formed by a posterior and an anterior articular point. The distal endopodite article is slightly curved laterally. Its anteriodistal wall is deepened and is forming a channel for transporting of spermatophores during the copulatory act (fig. 5: Chan). The distal region of the distal endopodite II-article is characterized by a complex cuticular structure.

In contrast to the plesiomorphous condition in *Stenasellus*, the male pleopod en-

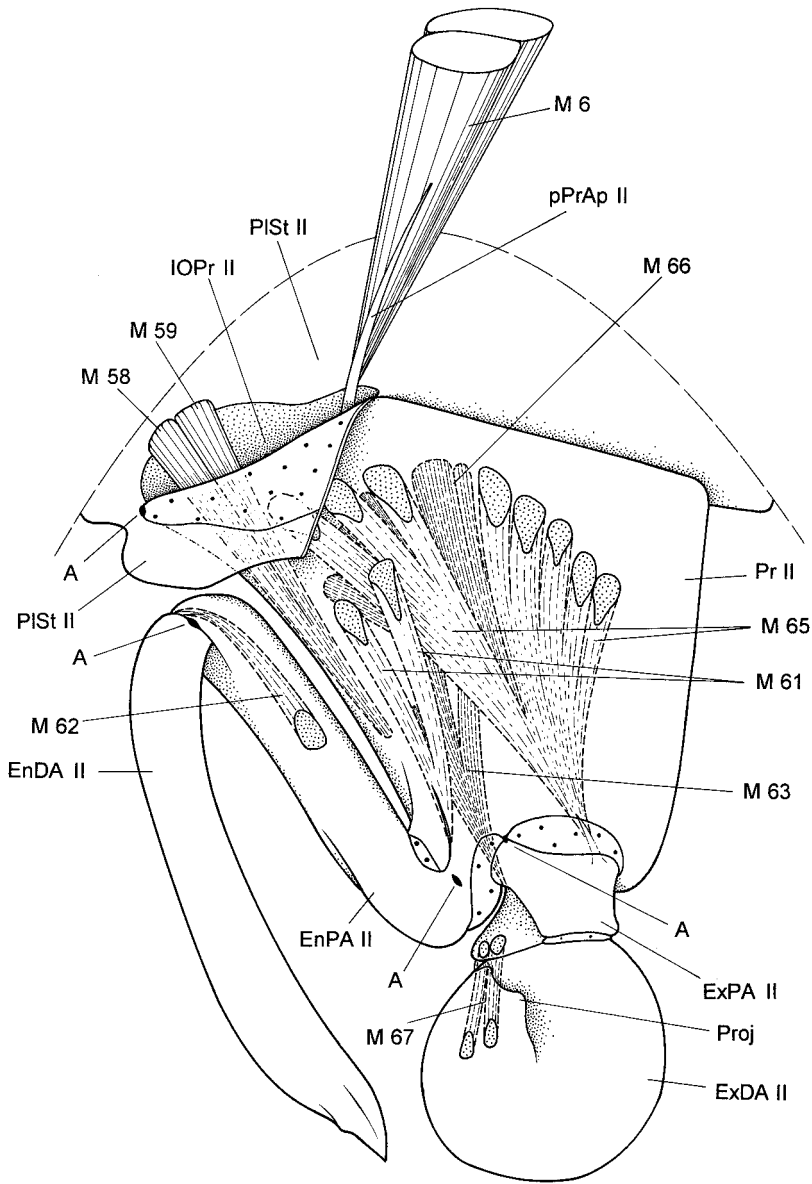

Fig. 8. *Stenasellus costai*, ♂, right pleopod II in posterior view. – Scale: 1 mm.

dopodite II of *Asellus aquaticus* is forming a complex gonopod (figs. 9–10). The medioproximal part of this gonopod shows a movable spur acting in concert with the exopodite II during copulation. In agreement with the hypothesis erected by MAGNIEZ (1996: 183) it is assumed here that the medial spur of *Asellus* (processus

calcariformis, cf. MAERCKS 1930) represents the distal article of the male pleopod endopodite II (appendix masculina) while the large rest of the endopodite might be homologous to the proximal endopodite II article of *Stenasellus* and most other isopodan taxa. Between the spur and the basal gonopod region a monocondylic articulation is developed with a proximal articular point. The spur might be able to move in distolateral direction by the action of the muscle M 62 which is also the locomotor of the distal joint of the male pleopod endopodite II in other isopodan groups like *Stenasellus*, the Oniscidea or the Phreatoicidea (figs. 7–8; cf. ERHARD 1995, 1999).

The large rest of the endopodite II (proximal endopodite article) has developed a sperm tube (fig. 9: Tube) with an anteriodistally located opening. This tube is filled with sperm at the beginning of the copulatory act (for details cf. MAERCKS 1930, WÄGELE 1989, MAGNIEZ 1996). The enlargement of the male proximal endopodite II article and the formation of the sperm tube as well as the transformation of the distal endopodite II joint (appendix masculina) into the medial spur (processus calcariformis) have to be considered as apomorphous features of *Asellus* in respect to the stenassellid, asellotan and isopodan groundpatterns.

The male pleopod protopodite II and the endopodite II of *Stenasellus costai* and *Asellus aquaticus* have a dicondylic articulation with posterior and anterior articular points (figs. 7–10). At the medial bases of the male endopodites II in both species an apophysis is developed which serves as point of insertion for the medial endopodite locomotor M 61.

4.2.1.2. Musculature

Within this chapter information on the *serial homology* of the muscles in the pleopods I–III is added. An overview on the serially homologous muscles within the oniscidean pleon is given in ERHARD (1995: 96) and within the phreatoicidean pleopods in ERHARD (1999: 12).

Mm 58/59: Intrinsic promotor of the pleopod protopodite II. Arises medially on the anterior pleon sternite II, passes the membrane between sternite II and pleopod protopodite II and is inserted distomedially on the anterior wall of the protopodite II. In *Stenasellus costai* composed of two neighbouring branches, in *Asellus aquaticus* formed by a single bundle. Homologous to Mm 58/59 of the Phreatoicidea (cf. ERHARD 1999: 12) and the Oniscidea (cf. ERHARD 1995, 1996, 1997). Serially homologous to Mm 48 and 71/72 within the pleopods I and III. Synonymous with “m₁i” of *Asellus aquaticus* in MAERCKS (1930: 409).

M 60: The muscle present in the oniscidean groundpattern (ERHARD 1995: 58) is missing in *Stenasellus costai* and *Asellus aquaticus* (cf. chapt. 4.2.2.: “Locomotors of the pleopod endopodite II”).

M 61: Moves the male pleopod endopodite II in mediodistal (*Stenasellus*) or medial (*Asellus*) direction. Arises on the posterior wall of protopodite II and is inserted on the medial apophysis of the pleopod endopodite II. Composed of two main bundles in *Stenasellus costai* and 7–10 branches in *Asellus aquaticus*. Homologous to M 61 of the Phreatoicidea (cf. ERHARD 1999: 12) and the Oniscidea (cf. ERHARD 1995, 1996, 1997). Serially homologous to M 73 (pleopods III) and M 103 (uropods). Synonymous with “m₃” of *Asellus aquaticus* in MAERCKS (1930: 409).

M 62: Locomotor of the distal endopodite II-article (appendix masculina) in male specimens of *Stenasellus costai*. Arises on the posterior wall of the proximal pleopod

endopodite II-article and is inserted on the medial basis of the appendix masculina. Composed of one branch. In *Asellus aquaticus* M 62 moves the medial spur (processus calcariformis, cf. MAERCKES 1930) which has to be considered as the modified distal article of the male pleopod endopodite II (appendix masculina) (cf. chapt. 4.2.1.1.). The asellotan M 62 is homologous to M 62 of the Phreatoicidea (cf. ERHARD 1999: 12) and the Oniscidea (cf. ERHARD 1995, 1996, 1997) and might be synonymous with “men” of *Asellus aquaticus* in MAERCKES (1930: 409).

M 63: Arises medioidistally on the anterior wall of pleopod protopodite II and is inserted on the medial apophysis of the pleopod exopodite II. Composed of 3–4 bundles in *Stenasellus costai* and 5–6 branches in *Asellus aquaticus*. Moves the exopodite II in medial direction. Presumably, homologous to M 63 of the Oniscidea (cf. ERHARD 1995, 1996, 1997) and the Phreatoicidea (cf. ERHARD 1999: 12). Serially homologous to M 53 and M 76 within the pleopods I and III. Synonymous with “m₂i” of *Asellus aquaticus* in MAERCKES (1930: 409).

M 64: The muscle present in the Phreatoicidea (cf. ERHARD 1999: 16) and probably in the Oniscidea-Crinocheta (cf. ERHARD 1995: 46) could not be shown in the investigated asellotan species.

Mm 65/66: The very strong muscles move the pleopod exopodite II in lateral direction. Composed of two distinct muscle groups. One group (M 65) arises on the posterior wall of the protopodite II and is composed of about 10–12 bundles. The second group (M 66) takes its origin on the anterior protopodite wall and is composed of about 5 bundles in *Stenasellus costai* and of 15–20 bundles in *Asellus aquaticus*. Both muscle groups are inserted on the lateral apophysis of pleopod exopodite II. Homologous to Mm 65/66 of the Oniscidea (cf. ERHARD 1995, 1996, 1997) and the Phreatoicidea (cf. ERHARD 1999: 16). Serially homologous to Mm 54/55 and 77/78 within the pleopods I and III. Synonymous with “m₂a” of *Asellus aquaticus* in MAERCKES (1930: 409).

M 67: Locomotor of the distal pleopod exopodite II-article. Arises medioidistally on the posterior wall of the proximal pleopod exopodite II-joint and is inserted medially on the posterior side of the distal exopodite II-article. Composed of two bundles in *Stenasellus costai* and of three branches in *Asellus aquaticus*. Presumably, homologous to M 67 of the Oniscidea (cf. ERHARD 1995, 1996, 1997) and of the Phreatoicidea (cf. ERHARD 1999: 16). Presumably, serially homologous to M 57 and M 80 within the pleopods I and III. Synonymous with “mex” of *Asellus aquaticus* in MAERCKES (1930: 409).

M 68: The muscle which is present in the pleopod protopodite II of the oniscid *Ligia oceanica* (ERHARD 1995: 49) could neither be shown in the Phreatoicidea (ERHARD 1999: 16) nor in the asellotans *Stenasellus costai* and *Asellus aquaticus*.

M 118: The medial pleopod exopodite II-locomotor present in the Phreatoicidea (ERHARD 1999: 16) could neither be shown in the Oniscidea (ERHARD 1995, 1996, 1997, 1999) nor in the investigated asellotan species.

Mm 119, 120, 122: The interarticular protopodite II-muscles are present in the Phreatoicidea (cf. ERHARD 1999: 16) but could not be shown in the pleopods II of the Oniscidea (cf. ERHARD 1995, 1996, 1997, 1999) and the investigated asellotan species.

M 121: The intrinsic pleopod endopodite II-muscle M 121 existent in the Phreatoicidea (cf. ERHARD 1999: 16) could not be shown in the pleopods II of the Oniscidea (cf. ERHARD 1995, 1996, 1997, 1999) and the investigated asellotan species.

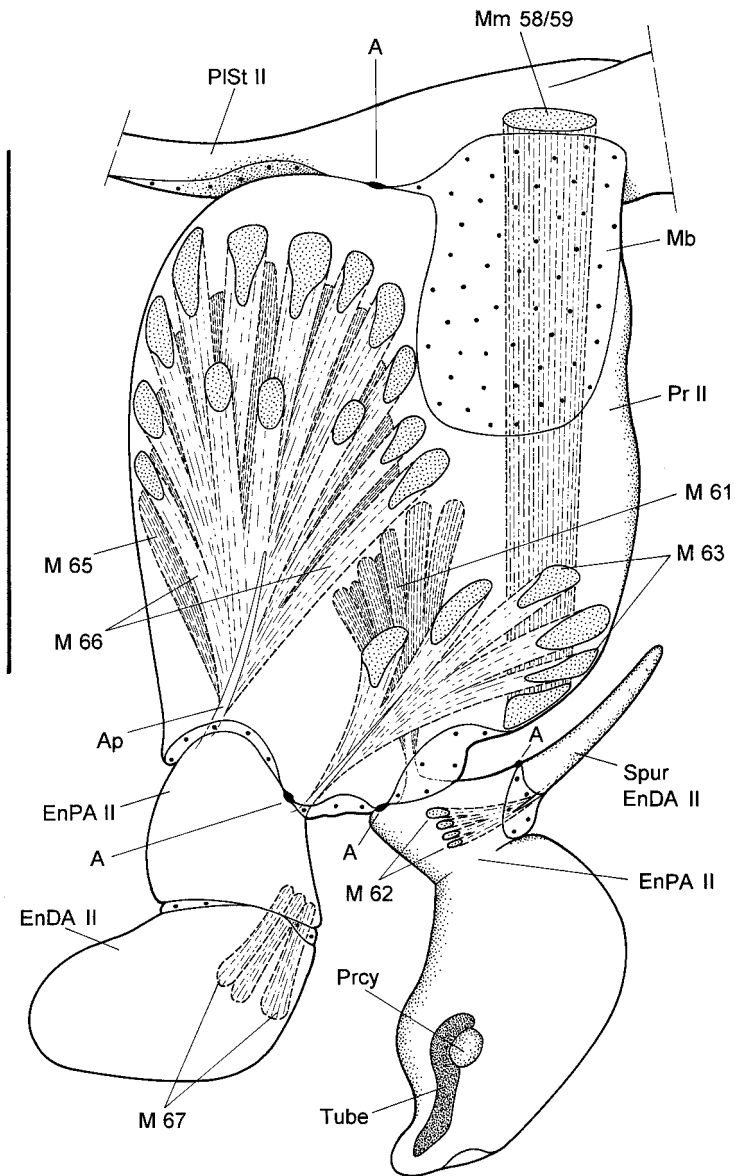

Fig. 9. *Asellus aquaticus*, ♂, right pleopod II in anterior view. – Scale: 0,5 mm.

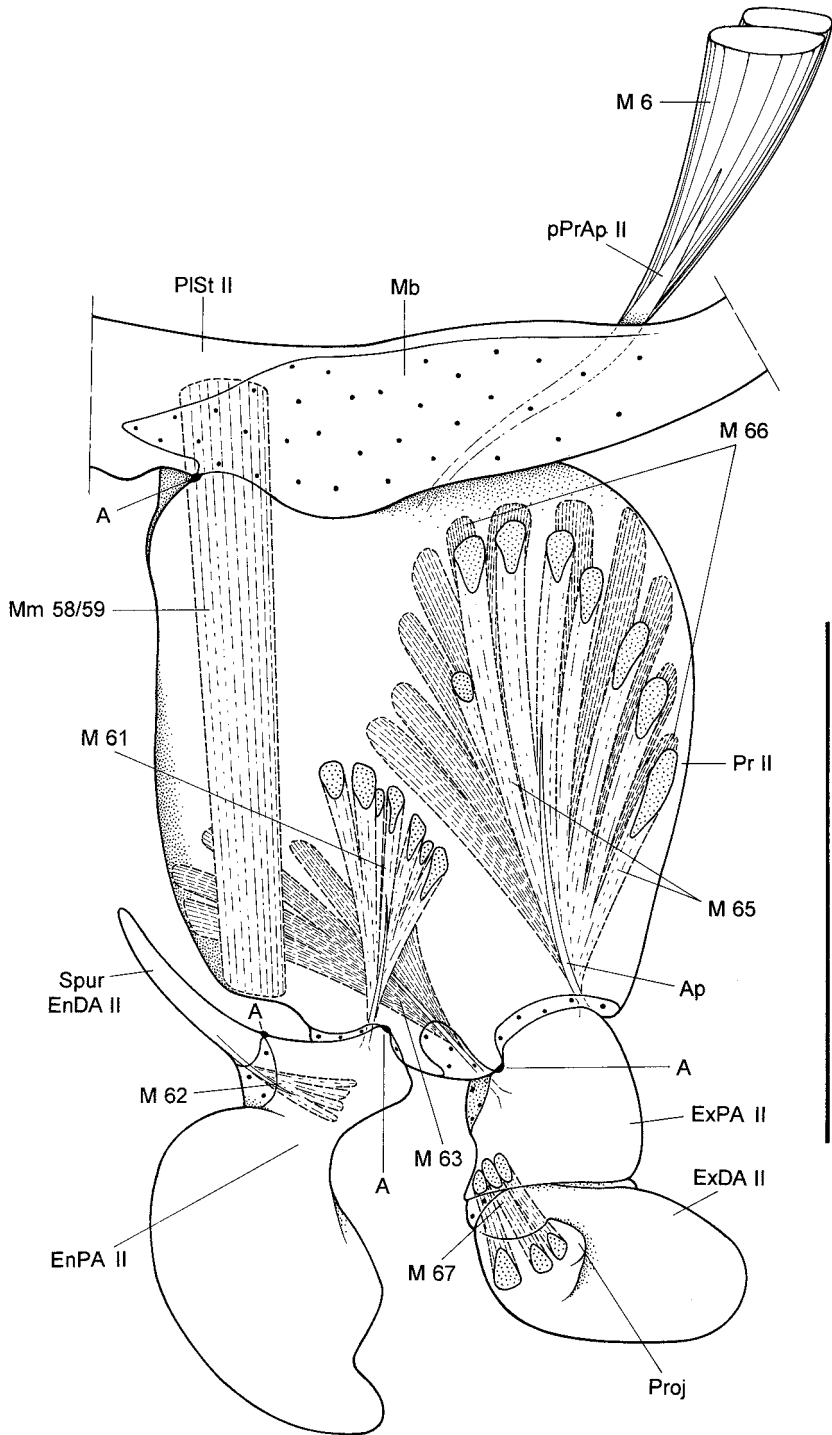
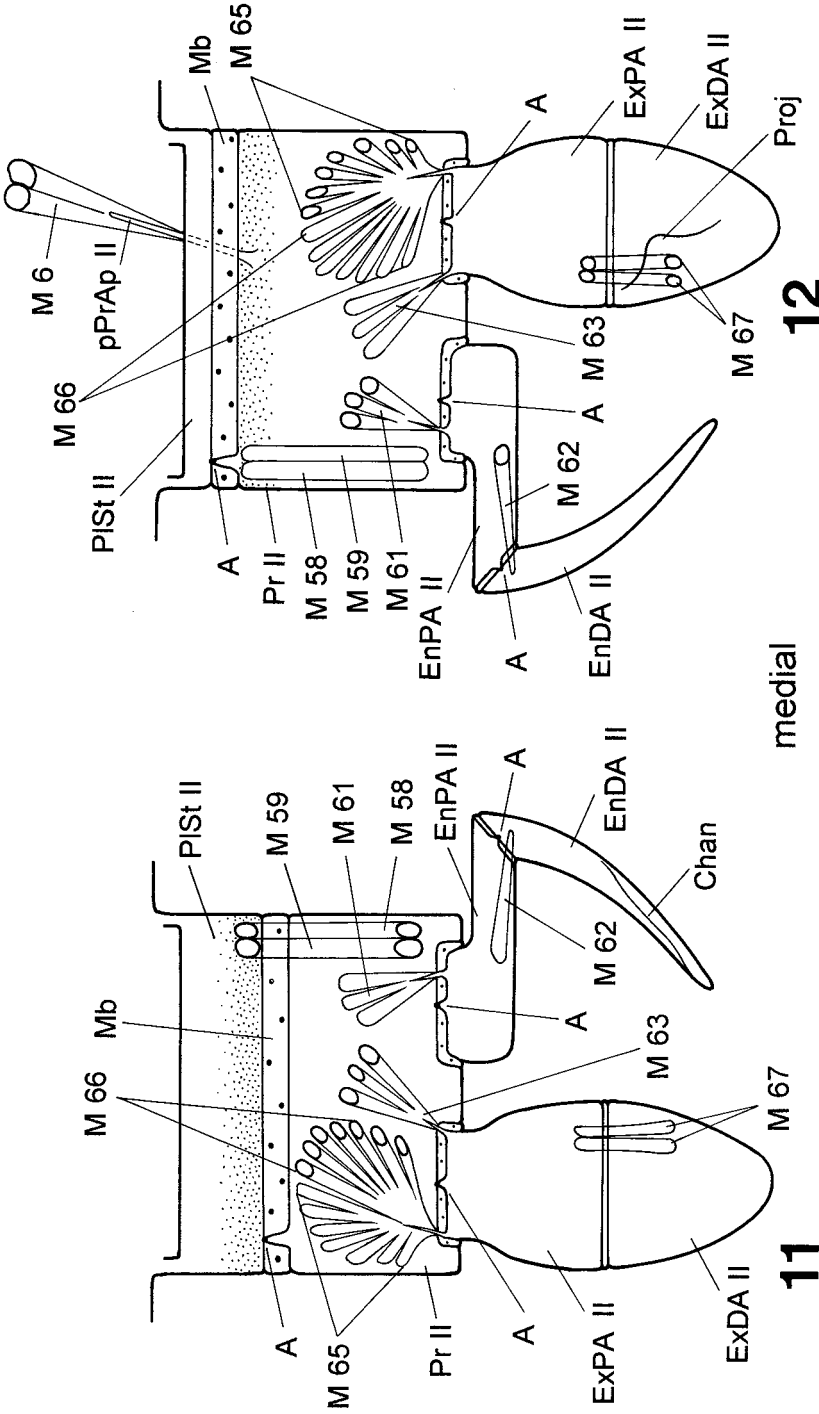

Fig. 10. *Asellus aquaticus*, ♂, right pleopod II in posterior view. – Scale: 0,5 mm.



Figs. 11-12. Diagrams of the skeleton and musculature of the male pleopods II within the hypothetical groundpattern of the Asellota (compare with corresponding diagrams of the Phreatoicoidea and Oniscidea in ERHARD 1999: figs. 12-15). The pleopodal rami are projected onto the same level. Areas of former protopodite articles indicated by *compact dotting*, membranes by *bold single dots*. - 11. Anterior view; - 12. posterior view.

4.2.2. Comparison (figs. 11–17)

– Articles of the male pleopod endopodite II

In male phreatoicidean specimens the biarticulate pleopod endopodite II is divided into a proximal leaflike joint and a mediobasal rodlike appendix masculina (fig. 14; ERHARD 1995: fig. 57; 1999: figs. 9, 11–13). This might be the plesiomorphous status of the male pleopod endopodite II in the Isopoda, retained also in the groundpatterns of further subordinate isopodan groups like Gnathiidea, Anthuridea, “Flabellifera” and Valvifera (figs. 13–14; cf. WILSON 1991: 234).

In the Asellota the plesiomorphous type of the male pleopod endopodite II consists also of two articles which are forming a right or mostly an acute angle (figs. 7–8, 11–12, 15; ERHARD 1995: fig. 57). This biarticulate type is still retained in all asellotan groups including *Vermectias* with the exception of species of the taxa Asellinae, Atlantasellidae and Microcerberidae which have modified male endopodite II-articles (cf. WÄGELE 1983, WILSON 1987, MAGNIEZ 1996). In contrast to the presumptive plesiomorphous condition present for example in the Phreatoicidea the proximal endopodite II-article of the Asellota has lost its distal leaflike part. The basal rest has been broadened in medial direction and took on a slender and elongate form. At the tip of the proximal joint the distal endopodite II-article is inserted showing the typical anterior groove for transferring sperm which is also present in other isopodan suborders (see paragraph below). There is no doubt that this distal endopodite joint of the Asellota is homologous to the appendix masculina of the Phreatoicidea, Anthuridea, “Flabellifera”, Gnathiidea and Valvifera. This assessment contradicts, however, the statement of WÄGELE (1989: 60) and GRUNER (1993: 877) since there should be no appendix masculina in asellotan species.

Concerning the asellotan condition of the male pleopod endopodites II (figs. 11–12, 15) the situation in the oniscidean groundpattern appears to be very similar (fig. 15; cf. ERHARD 1995: 58, 1999: figs. 14–15). The proximal endopodite II-joint has also lost the distal leaflike part and has been broadened in medial direction (cf. male pleopod endopodites II of *Ligia* and *Tylos* in ERHARD 1995: figs. 46, 48). The distal appendix masculina is positioned at right angles to the proximal endopodite article. The absence of the leaflike enlargement of the proximal article of the second male pleopod endopodite in the Oniscidea and the Asellota probably might be explained by the evolutionary loss of the ability of swimming formerly executed by pleopodal thrusts.

In respect to the plesiomorphous condition of the Phreatoicidea, Gnathiidea, Anthuridea, “Flabellifera” and Valvifera the loss of the distal leaflike part of the proximal endopodite II-article, the broadening of this proximal joint in medial direction (cf. *Ligia*, *Stenasellus*) and the resulting geniculate form on the entire gonopod in the asellotan and the oniscidean groundpatterns have to be considered as apomorphic character states (cf. ERHARD 1999: 17). At the present state of knowledge it remains unclear whether these modifications of the male endopodite II in the Asellota and Oniscidea are homologous.

The above described scenario, however, is contradictory to the assessment of SCHMALFUSS (1989: 10) that implies the absence of the leaflike enlargement of the proximal article of the male pleopod endopodite II to be a groundpattern character of the Isopoda and includes a new apomorphic development of this enlargement in the groups Phreatoicidea, Valvifera, “Flabellifera”, Anthuridea and

Gnathiidea. The more parsimonious explanation might be to expect a leaflike enlargement of the proximal article of the second male pleopod endopodite within the isopodan groundpattern because in this groundpattern all other pleopod endopodites show a corresponding leaflike appearance as it is also the condition in all pleopod endopodites of the presumptive isopodan sistergroup Tanaidacea (e. g. *Apseudes latreillii*). The ontogenetical development of the appendix masculina reported by KINNE (1954) on the isopod *Sphaeroma hookeri* (Sphaeromatidae) also demonstrates the formation of the appendix by a mediobasal partition at the leaflike endopodite II-article. This might indicate that the evolutionary development could have happened in a corresponding way. Furthermore, at the present state of knowledge there are convincing arguments concerning for example the position of the genital papillae and the pass of the vasa deferentia (cf. ERHARD 1998a) which plead for a basal phylogenetic-systematic position of the Phreatoicidea in respect to all other isopodan groups. Therefore, it should not be surprising if the Phreatoicidea show also a plesiomorphous character state regarding the male pleopod endopodite II. If we assume that the Phreatoicidea represent a very basal isopodan group and the Valvifera, "Flabellifera", Anthuridea and Gnathiidea are terminal taxa within the isopodan dendrogram (cf. WÄGELE 1989, BRUSCA & WILSON 1991) also the assumption of a multiple secondary development of the leaflike part of the proximal male endopodite II-article would be unnecessary by the assessment of a leaflike enlargement of the proximal endopodite II-joint within the isopodan groundpattern.

Concerning the above described evolutionary scenario of the male pleopod endopodite II the interpretation of the condition in *Tanaidacea* and *Calabozoa*, however, seems to be obscure. According to WILSON & PONDER (1992: figs. 8 B–C) and Van LIESHOUT (1983: fig. 4 E) the male pleopod endopodites II in both groups are uniarticulate rodlike structures without any leaflike parts (figs. 16–17). In the groundpatterns of all other isopodan suborders (except the Epicaridea which do not have male appendices masculinae) biarticulate male pleopod endopodites II occur. On account of the ontogenetical development of the appendix masculina as a mediobasal partition at the leaflike endopodite II in *Sphaeroma hookeri* (KINNE 1954) the retention of a leaflike part at a proximal male endopodite II-article in different isopodan groups is understandable. That might also indicate that the evolutionary development of the isopodan appendix masculina could have happened in a corresponding way. This assessment implies, however, that the uniarticulate male endopodites II of *Tainisopus* and *Calabozoa* are derived structures. They probably might be formed by fusion of both endopodite articles and by reduction of the laterobasal leaflike part.

Less parsimonious seems to be the assessment that the uniarticulate type of the male endopodite II present in *Tainisopus* and *Calabozoa* represents the character state within the isopodan groundpattern. If male specimens of the last common ancestor of the Isopoda would have had gonopods formed by an uniarticulate rodlike pleopod endopodite II it would be rather difficult to explain the ontogenetical development of the appendix masculina in *Sphaeroma hookeri* (KINNE 1954) and the fact that in so much isopodan groups leaflike respiratory and/or locomotory parts of the proximal male endopodite II-article have been retained.

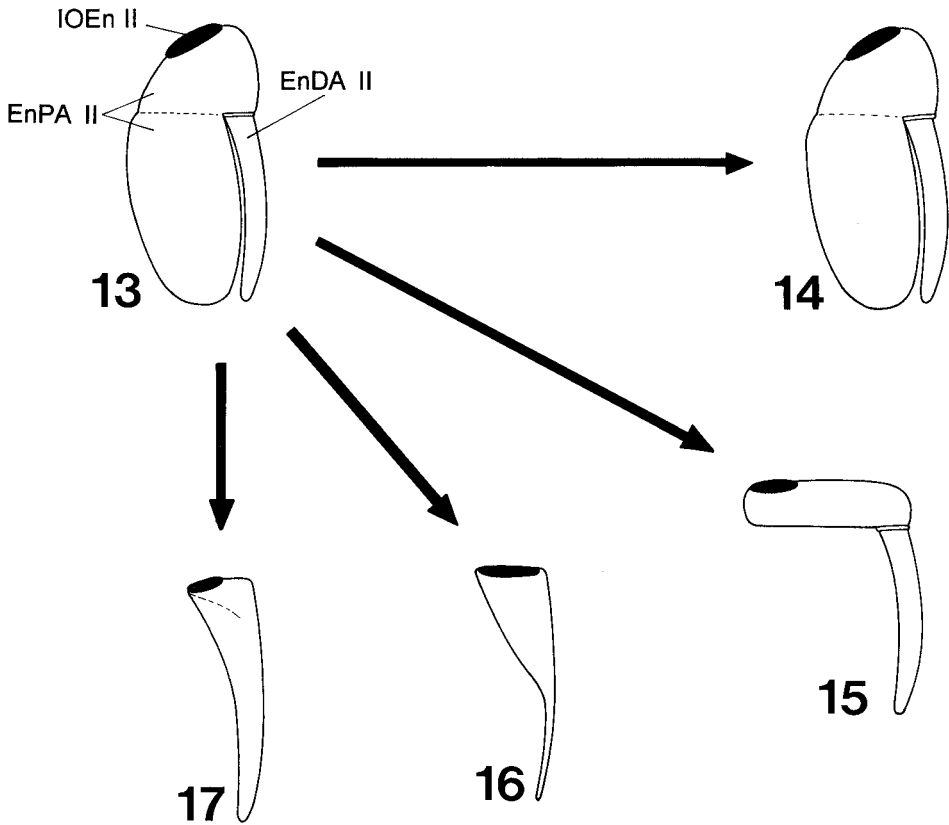

Figs. 13–17. Diagrams of the skeleton of the male pleopod endopodites II within the ground-patterns of the Isopoda and subordinate isopodan taxa (for explanations compare chart. 4.2.2.: “Articles of the male pleopod endopodite II”). The scheme does not reflect phylogenetic relationships. – 13. Isopoda; – 14. Phreatoicoidea, Anthuridea, Valvifera, Gnathiidea, “Flabellifera”; – 15. Asellota, Oniscidea; – 16. Calabozzoidea (after VAN LIESHOUT 1983); – 17. *Tainisopus* (after WILSON & PONDER 1992).

– Channel of the appendix masculina

In the phreatoicoidean and oniscidean groundpatterns (cf. ERHARD 1996: 22, 1999: 20) as well as in the valviferan *Saduria entomon* (cf. ERHARD 1996: fig. 17) the anterior wall of the distal male pleopod endopodite II-article (= appendix masculina) is deepened, forming a groove for the distally directed transport of spermatophores during the copulatory act. In the incertae sedis group *Tainisopus* a comparable groove is present at the anterior side of the uniarticulate male pleopod endopodite II (WILSON & KEABLE in press). An “open furrow” is furthermore reported by VAN LIESHOUT (1983: 169) for the uniarticulate male pleopod endopodite II of *Calabozoa*. Also in the basal asellotan species *Stenasellus costai* and *Vermectias nelladanae* a channel for transferring sperm could be shown at the distal male pleopod endopodite II-article (fig. 7). Corresponding simple anterio-lateral sperm grooves are reported by JUST & POORE (1992: 137) for *Pseudojanira* as well as by SEROV & WILSON (1995: 46) for the Stenetriidae.

This pattern of character states indicates that the presence of an anterior sperm groove might be a groundpattern character of the Isopoda retained in the Phreatoicoidea, *Tainisopus*, Calabozoidea, Asellota, Oniscidea, Valvifera and probably other isopodan taxa. However, derived conditions of the appendix masculina as for example the needlelike appendix in the phreatoicid *Nicholsia kashiensis* (cf. ERHARD 1999: fig. 16), the sperm tube in the Asellidae (cf. fig. 3) or the medial sperm channels in the Oniscidea-Holoverticata (= all non-ligiid Oniscidea, cf. ERHARD 1996, 1998b) frequently occur in subordinate taxa.

– Shape of the appendix masculina

In the phreatoicoidean groundpattern the distal article of the male pleopod endopodite II (appendix masculina) is curved laterally (cf. ERHARD 1999: 17). Therefore, a functional cooperation by the distal parts of the appendices of both sides during copulation has not to be supposed because of the spatial distance of both regions. Such a cooperation can neither be assumed for the Asellota because most distal joints of the male endopodite II of asellotan species are slightly curved laterally or are directed laterally (figs. 7–8). Furthermore, the asellotan coupling mechanism between male pleopod exopodite and endopodite II probably supports only a separate insemination executed by a single gonopod, as reported by MAERCKX (1930) on *Asellus aquaticus*, and not the action of both gonopods in concert. Like most phreatoicoideans the isopodan incertae sedis group *Tainisopus* and the Calabozoidea show laterally curved male pleopod endopodites II (cf. WILSON & PONDER 1992).

Within the oniscidean groundpattern both appendices masculinae (= distal articles of male pleopod endopodite II) have linear shapes and are positioned in the mid-ventral region of the pleon ventrum side by side or one upon another (ERHARD 1996: 23). Thus, they are able to work together during copulation for the purpose of sperm transport to the female gonopore. This character state, presumably, has to be considered as apomorphic in respect to the isopodan groundpattern.

– Articulation between the endopodite II-articles

Between the proximal male endopodite II-joint and the distal endopodite II-article (appendix masculina) in the phreatoicoidean and the oniscidean groundpatterns a dicondylic articulation is present (ERHARD 1997: 43, 1999: 17). A corresponding condition occurs in the basal asellotan species *Stenasellus costai* wherefore a dicondylic articulation between the male pleopod endopodite II-articles also has to be supposed for the asellotan groundpattern.

– Coupling mechanism between male pleopod exopodite and endopodite II

The presence of coupling structures of the male pleopod exopodite and endopodite II described in chapter 4.2.1.1. for *Stenasellus costai* and *Asellus aquaticus* might be a common feature in asellotan species. According to WILSON (1987: 265), “the interlocking of the (male pleopod) endopod and exopod (II) is homologous in all asellotan taxa because they all have elongated and enlarged exopodal musculature for the copulatory function”. Thus, the coupling mechanism between the male pleopod endopodite and exopodite II in its general form might probably represent an autapomorphic character state of the Asellota in respect to the isopodan, phreatoicoidean and oniscidean groundpatterns.

– Female pleopod II

According to WÄGELE (1989: 58) the complete reduction of the female pleopod endopodite II represents an autapomorphy of the Asellota. In contrast, the female pleopod endopodite II is still present in the Oniscidea, Phreatoicoidea, Calabozoidea and *Tainisopus*.

In the tanaidacean *Apseudes latreillii* as well as in the isopodan taxa Phreatoicoidea (cf. WILSON & HO 1996) and *Tainisopus* (cf. WILSON & PONDER 1992) the female and the male pleopod exopodite II are composed of two articles which might represent the plesiomorphous character state in respect to the isopodan groundpattern. In contrast, the female pleopod exopodite II within the asellotan groundpattern is composed only of a single joint while the male exopodite II and the pleopod exopodites III–V in both sexes are biarticulate. This uniarticulate status of the female exopodite II has to be considered an autapomorphous condition of the Asellota (in *Vermectias* the female pleopod II is completely reduced). In the Calabozoidea (cf. Van LIESHOUT 1983) and the Oniscidea only uniarticulate pleopod exopodites I–V occur in females as well as in males which are also apomorphous in respect to the isopodan groundpattern.

– Locomotors of the pleopod endopodite II Mm 60 and 61

In the tanaidacean *Apseudes latreillii*, in the Phreatoicoidea as well as in *Stenasellus costai*, *Asellus aquaticus* and *Vermectias nelladanae* only the medial pleopod endopodite II-locomotor M 61 is developed. A comparable situation with only one endopodite locomotor occurs within the pleopods I, III–V and the uropods of the tanaidacean *Apseudes*, the Phreatoicoidea and Oniscidea (ERHARD 1995, 1999) as well as in the pleopods III–V and the uropods of the investigated asellotan species.

In contrast, in the oniscidean groundpattern two distinct locomotors of the pleopod endopodite II are present, inserting on the medial (M 61) and the lateral (M 60) endopodite basis (ERHARD 1995, 1996, 1997). A corresponding condition with two endopodite II-locomotors is figured by WILSON (1987: figs. 1E, 3D) for *Stenetrium dagama* (Stenetrioidea) and for *Eurycope diadela* (Janiroidea) as well as VEUILLE (1978: fig. 3) for *Jaera italica* (Janiroidea).

This pattern of character states reveals the existence of an additional lateral endopodite II-locomotor M 60 within the oniscidean groundpattern and probably in some subordinate asellotan groups to be an apomorphous condition in comparison with the plesiomorphous status within the phreatoicoidean and, presumably, the isopodan groundpattern. Whether this apomorphous character state occurs also in the asellotan groundpattern remains unclear at the present state of knowledge.

– Locomotor of the appendix masculina M 62

In the Asellota (e. g. in *Stenasellus*, *Asellus* and *Vermectias*) as well as in the Oniscidea and Phreatoicoidea (cf. ERHARD 1995, 1996, 1997, 1999) the distal article of the male pleopod endopodite II is moved by the muscle M 62. The presence of M 62 is assumed to be a groundpattern character of the Isopoda.

M 62 is inserted in the asellotans *Stenasellus* and *Vermectias* on the medial basis of the appendix masculina while in the Phreatoicoidea and Oniscidea the homologous muscle is inserted on the lateral basis (figs. 7–8; cf. ERHARD 1995, 1996, 1997, 1999).

– Enlargement of the lateral exopodite II-locomotors Mm 65/66

As already noticed by MAERCKS (1930: 418) on male specimens of *Asellus aquaticus* the lateral pleopod exopodite II-locomotors Mm 65/66 are strongly developed in comparison with homologous muscles in non-asellotans or with serially homologous muscle pairs in the pleopods I and III–V. The enlargement of Mm 65/66, which also could be observed in *Stenasellus costai* and *Vermectias nel-*

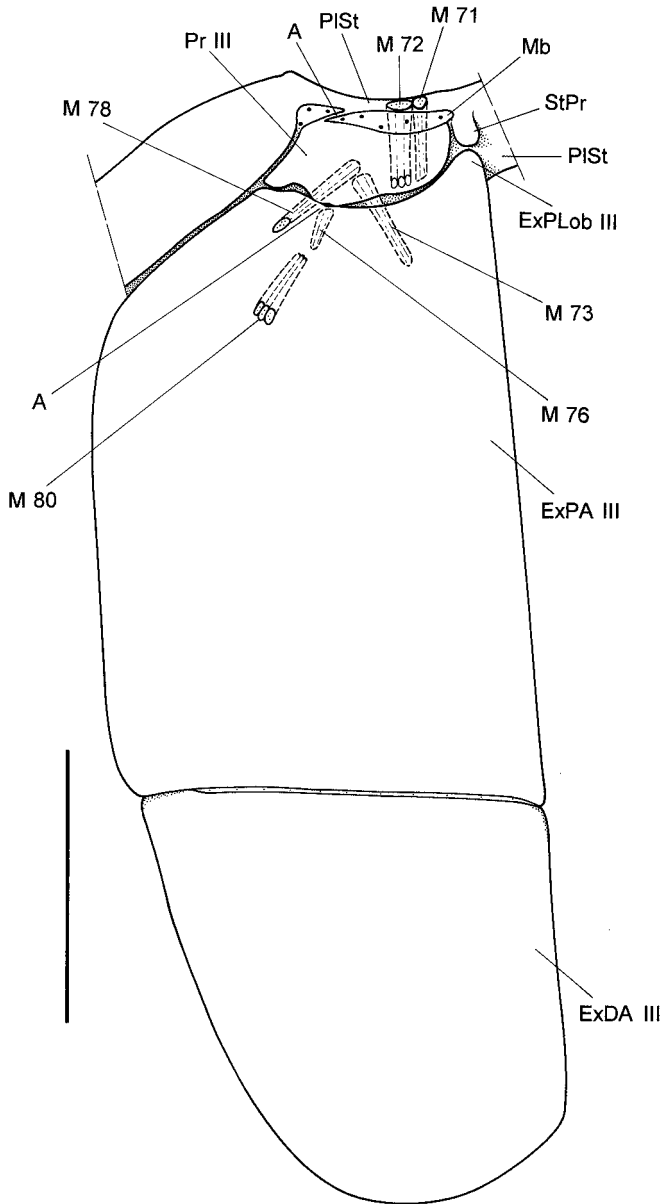

Fig. 18. *Stenasellus costai*, ♂, right pleopod III in anterior view. – Scale: 1 mm.

ladanae, presumably, is caused by the fact that the muscles are responsible for the laterally directed movement of the exopodite after interlocking with the pleopod endopodite II during copulation (cf. chapt. 4.2.1.1. and MAERCKES 1930: 460). Additionally, WILSON (1987: 265) pointed out that “the interlocking of the endopod and exopod is homologous in all asellotan taxa because they all have elongated and enlarged exopodal musculature for the (special) copulatory function”. Fol-

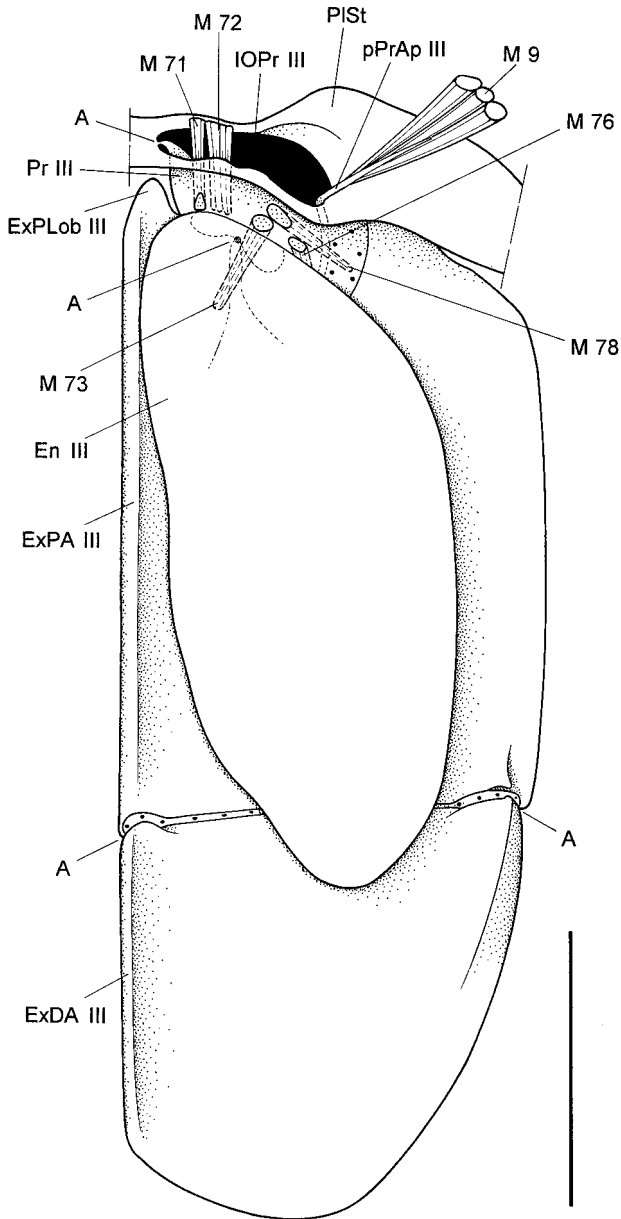

Fig. 19. *Stenasellus costai*, ♂, right pleopod III in posterior view. – Scale: 1 mm.

lowing this, the enlargement of the male pleopod exopodite II-muscles Mm 65/66 within the Asellota has to be considered as an autapomorphy of the Asellota in comparison with the plesiomorphous “normal” condition present for example in the Phreatoicidea and Oniscidea.

– Locomotor of the male pleopod exopodite II M 67

In male specimens of *Stenasellus costai*, *Asellus aquaticus* and *Vermectias nelladanae* a locomotor of the distal pleopod exopodite II-article occurs (figs. 7–12: M 67). In all other pleopods of the investigated asellotan species which possess two exopodite articles (pleopods III–V) a corresponding locomotor of the distal exopodite joint is missing. This condition also is present within all biarticulate pleopod exopodites of the Tanaidacea (*Apseudes*) and the isopodan taxon Phreatoicidea including those of the pleopods II (cf. ERHARD 1999). In the Oniscidea only uniaarticulate pleopod exopodites occur.

However, in the groundpatterns of the Tanaidacea, Phreatoicidea, Calabozoidea and Oniscidea exopodite locomotors are present (e. g. Mm 57, 67, 80 within the pleopods I–III) which normally arise on the protopodites and are inserted on the proximal parts or articles of the pleopod exopodites (cf. ERHARD 1995, 1996, 1997, 1999). This state also is shown by the pleopods I and III–V of the investigated asellotan species with two exopodite articles. In contrast, the male pleopod exopodite II of *Stenasellus*, *Asellus* and *Vermectias* lacks such a basal exopodite muscle but shows an interarticular locomotor which moves the distal exopodite article (figs. 7–12).

This pattern of character indicates that the existence of an interarticular locomotor of the asellotan pleopod exopodite II represents clearly an apomorphic status in relation to the isopodan groundpattern. With all probability, the formerly basal exopodite II locomotor M 67 has changed its position and function and is transformed to an intrarticular muscle now acting between both exopodite II-joints. Presumably, this was caused by the evolutionary development of the interlocking mechanism of the pleopod exopodite II distal article and the endopodite II during the copulatory act (cf. chapt. 4.2.1.1. and MAERCKS 1930: 460).

4.3. Pleopods III

4.3.1. Asellotan species (figs. 18–22)

4.3.1.1. Skeleton

The male pleopods III of *Stenasellus costai* and *Asellus aquaticus* consist of a protopodite, an exopodite and an endopodite (the pleopod III of *Vermectias nelladanae* is reduced to a single article without intrinsic musculature, only the extrinsic depressor M 9 is retained). The protopodites of *Stenasellus* and *Asellus* lack lateral epipodites as well as medial lobes or coupling structures. The pleopod exopodites III of *Stenasellus* and *Asellus* are developed as opercula which are covering the pleopod endopodites III and the pleopods IV and V (cf. ERHARD 2001: figs. 1, 4, 5, 8, 9). The pleopod exo- and endopodites III appear to be enlarged in comparison with the small protopodites III. Between both pleopod protopodites III small sternal processes are developed in *Stenasellus* as well as in *Asellus* (figs. 18, 21).

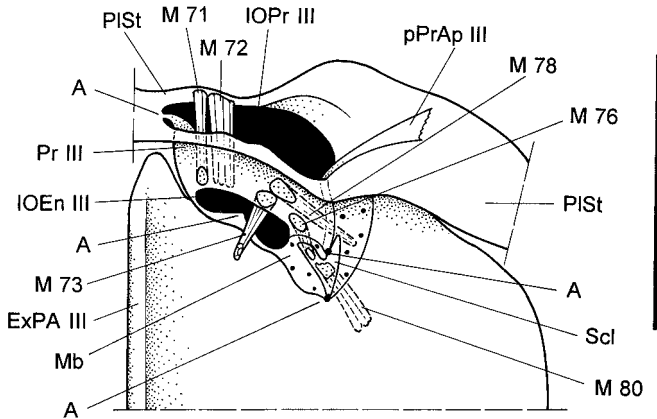

Fig. 20. *Stenasellus costai*, ♂, proximal region of right pleopod III in posterior view. Endopodite and the muscle M 9 removed. – Scale: 1 mm.

The male pleopod protopodite III of *Stenasellus costai* and *Asellus aquaticus* is formed by a single article. Between protopodite III and the sternite medioposterior and lateroanterior articular points are developed. Thus the pleopods III are able to perform movements in anterior and posterior direction. Between the pleon sternite and the medioanterior wall of the protopodite III a conspicuous membrane is developed. At the basal posterior wall of the protopodite III a large apophysis as point of insertion for the tergal protopodite III-remotor M 9 is present. The basis of the apophysis is lengthened by a thin sclerite stretched over the protopodite-exopodite articulation into the exopodite. Thus the power of the protopodite remotor M 9 might be transported mainly to the operculate and enlarged exopodite III and may cause a dorsally directed pressure on the pleopods IV and V.

In the investigated asellotans *Asellus* and *Stenasellus* the male pleopod exopodite III is formed by two separate and broad articles (figs. 18–19, 21–22). The pleopod protopodite III and the basal exopodite III-joint have a dicondylic articulation. The articular points are located anteriorly and posteriorly. The intersegmental region between both exopodite III-articles is stretched over the entire exopodite width. At the posterior-medial and -lateral margins conspicuous articular points are developed (fig. 19). The basal joint of the exopodite III in *Stenasellus costai* has a small medioproximal lobe whereas in *Asellus aquaticus* a very small lateroproximal extension occurs (the exopodites IV and V of *Stenasellus* have also small lateroproximal lobes).

In *Stenasellus costai* the anterior basis of the pleopod endopodite III is slightly sclerotized forming an articular point with the protopodite III. Apart from that sclerotized region, the entire endopodite wall is membranous and a posterior articular point with the protopodite could not be shown. However, in *Asellus aquaticus* also the posterior proximal endopodite part is sclerotized and an anterior as well as a posterior articular point with the protopodite is present. Corresponding to the situation in the pleopods I–V of most phreatoicidean species (cf. ERHARD 1999), the pleopod endopodites III–V of *Asellus* are composed of a short proximal sclerotized area and a large membranous distal region which often breaks off during manual preparation.

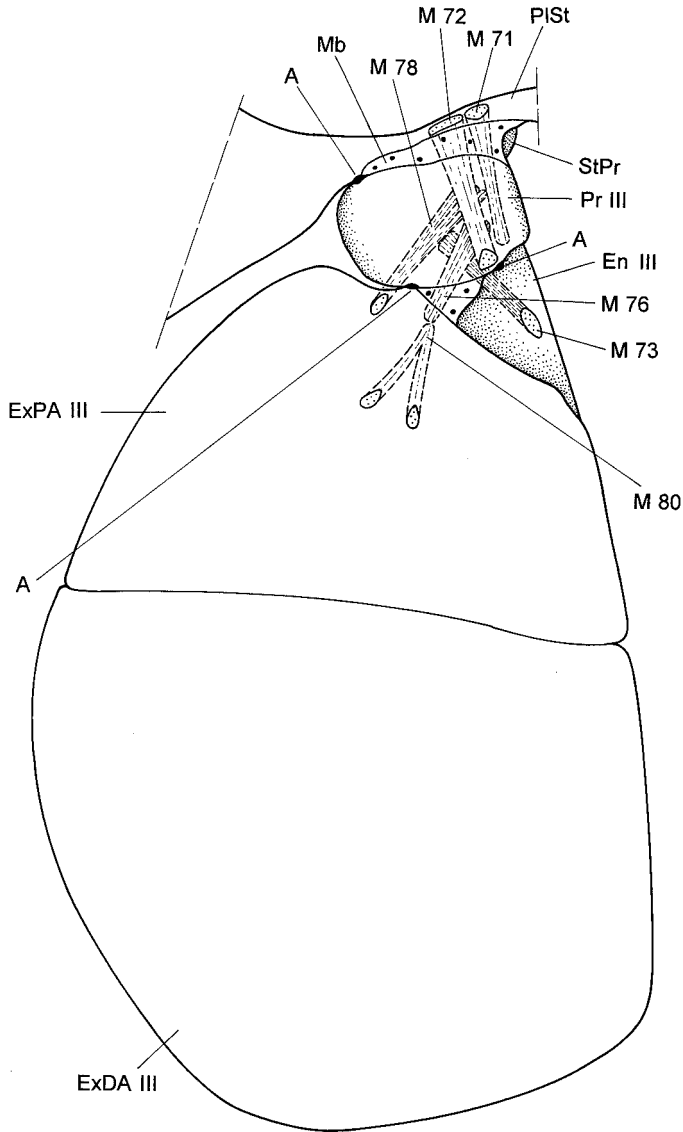

Fig. 21. *Asellus aquaticus*, ♂, right pleopod III in anterior view. – Scale: 1 mm.

4.3.1.2. Musculature

Mm 71/72: Promotors (depressors) of the pleopod protopodite III. In *Stenasellus costai* and *Asellus aquaticus* the muscles arise on the anterior part of pleon sternite III. The medial branch M 71 is inserted distally on the posterior protopodite III-wall whereas the strong lateral bundle M 72 is attached on the anteriodistal protopodite region. Homologous to Mm 71/72 of the Oniscidea (cf. ERHARD 1995, 1996, 1997) and Phreatoicoidea (cf. ERHARD 1999: 25).

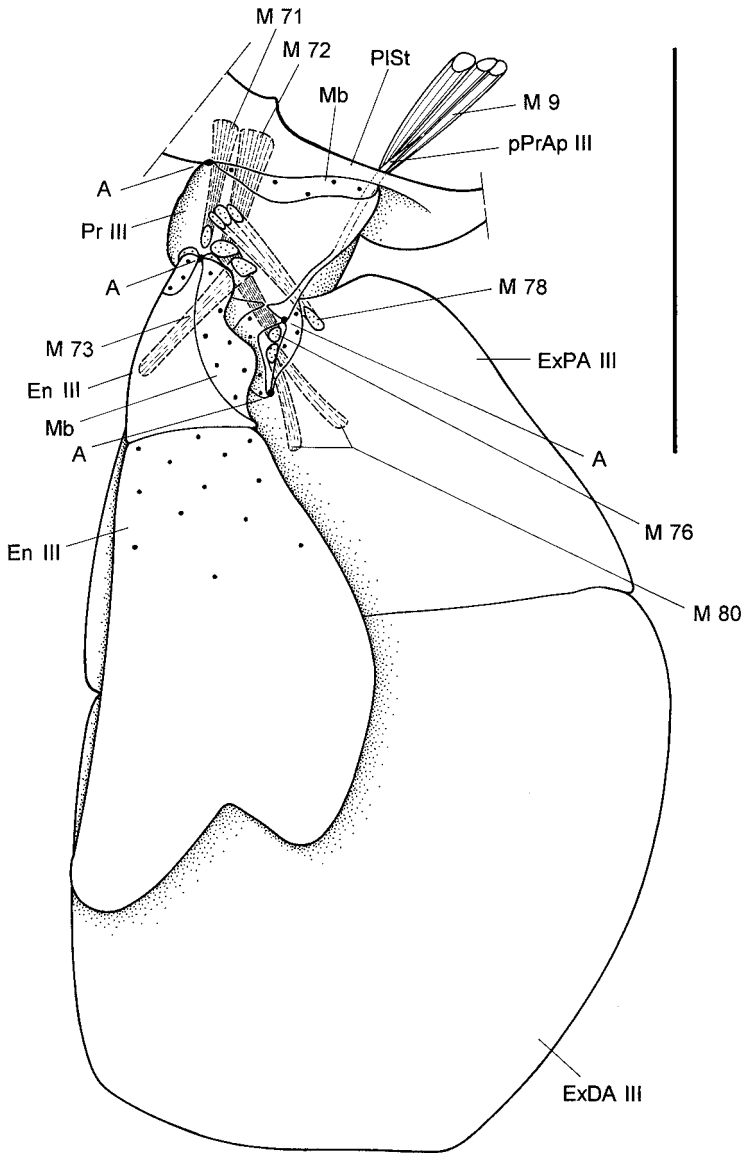

Fig. 22. *Asellus aquaticus*, ♂, right pleopod III in posterior view. – Scale: 1 mm.

M 73: Locomotor of the pleopod endopodite III. Arises in *Stenasellus* and *Asellus* distally on the posterior wall of the protopodite III and is inserted on the anterior basis of the endopodite III. Composed of one bundle. Homologous to M 73 of the Oniscidea (cf. ERHARD 1995, 1996, 1997) and Phreatoicidea (cf. ERHARD 1999: 25).

M 75: The muscle present in the Phreatoicidea (cf. ERHARD 1999: 25) and the Oniscidea (cf. ERHARD 1995: 59) could not be shown in the investigated asellotan species.

M 76: Medial exopodite III-locomotor. Arises distally on the posterior wall of protopodite III and is inserted on the posterior articular sclerite between protopodite and exopodite III. Composed of one bundle. Homologous to M 76 or, probably, M 79 of the Oniscidea (cf. ERHARD 1995, 1996, 1997) and the Phreatoicidea (cf. ERHARD 1999: 25).

M 77/78: Lateral exopodite III-locomotor. In *Stenasellus costai* and *Asellus aquaticus* only one lateral exopodite III-locomotor is present which arises distally on the posterior wall of protopodite III and is inserted on the lateral exopodite III-basis. According to the plesiomorphous condition retained in the Oniscidea-Orthogonopoda (= Mesoniscidea + Synocheta + Crinocheta; cf. ERHARD 1995, 1996, 1997) with two distinct lateral exopodite locomotors, the preserved asellotan muscle might represent M 78 on account of its posterior origin. The lateral exopodite locomotor M 77 which arises in the Oniscidea-Orthogonopoda on the anterior protopodite wall obviously has been completely reduced within the investigated asellotan species. M 78 of the Asellota is homologous to M 78 of the Oniscidea (cf. ERHARD 1995: 59) and the Phreatoicidea (cf. ERHARD 1999: 25).

M 79: The medial pleopod exopodite locomotor M 79 present in the Oniscidea (cf. ERHARD 1995, 1996, 1997) and the Phreatoicidea (cf. ERHARD 1999: 25) could not be shown with certainty in the investigated asellotan species (compare M 76).

M 80: Locomotor of the pleopod exopodite III. Arises distally on the posterior sclerite between protopodite III and exopodite III and is inserted on the anterior wall of the proximal exopodite III-article. Composed of two bundles in *Asellus aquaticus* and of three branches in *Stenasellus costai*. Homologous to M 80 of the Oniscidea (cf. ERHARD 1995, 1996, 1997) and the Phreatoicidea (cf. ERHARD 1999: 25).

Mm 123–125: The interarticular protopodite III-muscles are present in the Phreatoicidea (cf. ERHARD 1999: 25) but could not be shown in the pleopods III of the Oniscidea (cf. ERHARD 1995, 1996, 1997, 1999) and the investigated asellotan species.

M 126: The intrinsic pleopod endopodite III-muscle M 126 existent in the Phreatoicidea (cf. ERHARD 1999: 26) could not be shown in the pleopods III of the Oniscidea (cf. ERHARD 1995, 1996, 1997) and the investigated asellotan species.

4.3.2. Comparison

– Opercula

In the Aselloidea and Stenetrioidea the pleopod exopodites III are modified as opercula covering the pleopod endopodites III as well as the pleopods IV and V at the ventral pleon side (cf. WÄGELE 1983, WILSON 1987, SEROV & WILSON 1995, ERHARD 2001: figs. 1, 4, 5). Together with the pleotelsonic ventrum the pleopod exopodites thus are forming a ventral chamber for the protection of the caudal pleopods. WILSON (1987) and WÄGELE (1989) pointed out, that the opercular pleopods III might represent a character of the asellotan groundpattern. Aselloidea-like pleopods III occur also in species of the genera *Pseudojanira* and *Notasellus* which are closely related to the basal Janiroidea. Reduced, non-opercular pleopods III as they occur for example in most janiroidean or protojaniroidean species have to be regarded as apomorphic features in respect to the asellotan groundpattern (WILSON 1987). Thus, the opercular pleopods III have to be con-

sidered as an apomorphic feature of the taxon Asellota. The non-opercular pleopods III present in the Phreatoicoidea or Oniscidea represent plesiomorphous character states in respect to the isopodan groundpattern.

JUST & POORE (1992) reported the pleopods III and IV of the asellotan genus *Vermetias* to be enlarged, inflated, uniramous and strongly sclerotized sacks without discernable protopodites. The pleopods V are missing and the pleopods III are not opercular. According to the mentioned authors this character status is considered as an apomorphy in relation to the asellotan groundpattern.

4.4. Comparison of characters concerning all pleopods (figs. 5–6, 11–12, 23–24)

4.4.1. Skeleton

– Sternal processus

Median sternal processus of the pereion and pleon segments are documented for Amphipoda, Tanaidacea (e. g. *Apseudes latreillii*), Oniscidea, Anthuridea, Valvifera and Phreatoicoidea (cf. ERHARD 1998a: 10). In the asellotan species *Sten- asellus costai* and *Asellus aquaticus* small sternal processus could be shown between the pleopod protopodites III (figs. 18, 21) and SEROV & WILSON (1995: 41) also notice “sternal keels” at the pereion sternites in species of the Asellota-Sten- etriidae. Provided that all the sternal processus in the mentioned peracaridan taxa are homologous these structures could represent plesiomorphous character states retained in the groundpatterns of most isopodan suborders.

– Protopodite joints and articulations

The occurrence of two pleopod protopodite joints in the Phreatoicoidea was interpreted by ERHARD (1999: 26) as a plesiomorphous status. Biarticulate pleopod protopodites I–V could also be shown in *Calabozoa pellucida* (Calabozoidea) and in the presumptive isopodan sistergroup Tanaidacea (*Apseudes latreillii*; cf. CLAUS 1884, SIEG 1984). In contrast, the oniscidean groundpattern includes only one protopodite article in the pleopods I–V (ERHARD 1999: 26). In the investigated asellotan species the pleopod protopodites also are formed by single joints. Their structure shows a conspicuous conformity with the oniscidean protopodites:

The apophysis of the pleopod remotor in both taxa is located on the protopodite back margin (figs. 2, 4, 8, 10, 19, 22: pPrAp; ERHARD 1999: figs. 7, 15, 23). In the Phreatoicoidea the homologous apophysis is inserted on the back margin of the proximal protopodite joint (ERHARD 1999: figs. 5, 13, 21). This plesiomorphous state indicates that the posterior walls of the former proximal articles of the oniscidean and asellotan ancestors must have been fused with the posterior parts of the distal protopodite joints.

In contrast, the anterior parts of the hypothetical proximal protopodite joints have obviously fused with the sternites in Oniscidea and Asellota because the intrinsic protopodite promoters Mm 48, 58/59, 71/72 (pleopods I–III) are attached on the sternites and pass a conspicuous medioanterior membrane. In the Phreatoicoidea, Calabozoidea and in the isopodan sistergroup Tanaidacea (cf. TABACARU & DANIELOPOL 1999; KOBUSCH 1999) the homologous muscles take their origin on the anterior wall of the proximal protopodite joints which might be the plesiomorphous status (ERHARD 1999: 32).

Furthermore, anterior pleopod promotor apophyses which are commonly present at the proximal protopodite joints of the Phreatoicoidea (cf. ERHARD 1998a: 12) are missing in the Oniscidea and Asellota (figs. 5, 11, 23; ERHARD 1999: figs. 6, 14, 22). The articular points between the sternites and the protopodites in the investigated asellotan species show exactly corresponding positions in comparison with the oniscidean groundpattern which includes medioposterior and lateroanterior hinges (chapters 4.1.1.1., 4.2.1.1., 4.3.1.1.; ERHARD 1995: 72). Thus the asellotan and oniscidean pleopods are able to perform movements in anterior and posterior direction. In the Phreatoicoidea the articular points between pleonal sternites and pleopod protopodites are situated posteriorly and laterally. Between the proximal and distal protopodite joints the hinges are positioned laterally and medially (ERHARD 1999: 27). Corresponding articular points could also be shown in *Calabozoa pellucida*.

The above mentioned conformity between the Oniscidea and Asellota concerning the structure and the articulation of the pleopod protopodites have to be considered as apomorphic character states in respect to the isopodan and the tanaidacean groundpatterns (cf. ERHARD 1999: 26). Further comparisons and analyses have to show whether the conditions of the Asellota and Oniscidea are to interpret as common apomorphies or convergencies.

– Articulation between pleopod protopodites and endopodites

According to ERHARD (1999: 27) the existence of dicondylic articulations between the male pleopod protopodites and endopodites I–V represents the plesiomorphic condition in respect to the isopodan groundpattern. This situation is retained in the phreatoicoidean groundpattern of all five pleopods, in the groundpattern of the pleopods II–V in the Asellota (e. g. *Asellus aquaticus*, cf. chapter 4.3.1.1.; the pleopod endopodites I are completely reduced in the Asellota) as well as in the male pleopods II of the Oniscidea. A reduction of articular points between protopodites and endopodites presumably on account of the lack of sclerotized basal parts of the endopodites then has to be interpreted as apomorphic character state which is present for example in the oniscidean pleopods III–V (ERHARD 1999: 28) and the pleopods III–V in subordinate asellotan groups like *Stenasellus* (cf. chapter 4.3.1.1.).

– Size and position of the pleopods I and II

In the groundpattern of the Tanaidacea, Isopoda and subordinate isopodan groups like Phreatoicoidea, Oniscidea or *Tainisopus* all pleopods are nearly the same size (cf. ERHARD 1995, 1999).

Within the groundpattern of the Asellota the male pleopods I and II are clearly smaller than the pleopods III–V which has to be considered as an apomorphic status (WILSON 1987: 265; ERHARD 2001: figs. 4, 5, 9). According to WILSON (1987: 265) large and lamellar pleopods I and II present in the Gnathostenetroidoidea, Protojaniroidea and Janiroidea are interpreted to be apomorphic in respect to the asellotan groundpattern because the most basal asellotan groups like Asellidae, Stenasellidae (Aselloidea), Vermectiidae and Stenetriidae are showing small pleopods I and II. All pleopods of the Atlantasellidae and Microcerberidae (Aselloidea) are of small size which might be an apomorphic character state in respect to the asellotan groundpattern (WÄGELE 1989: 65).

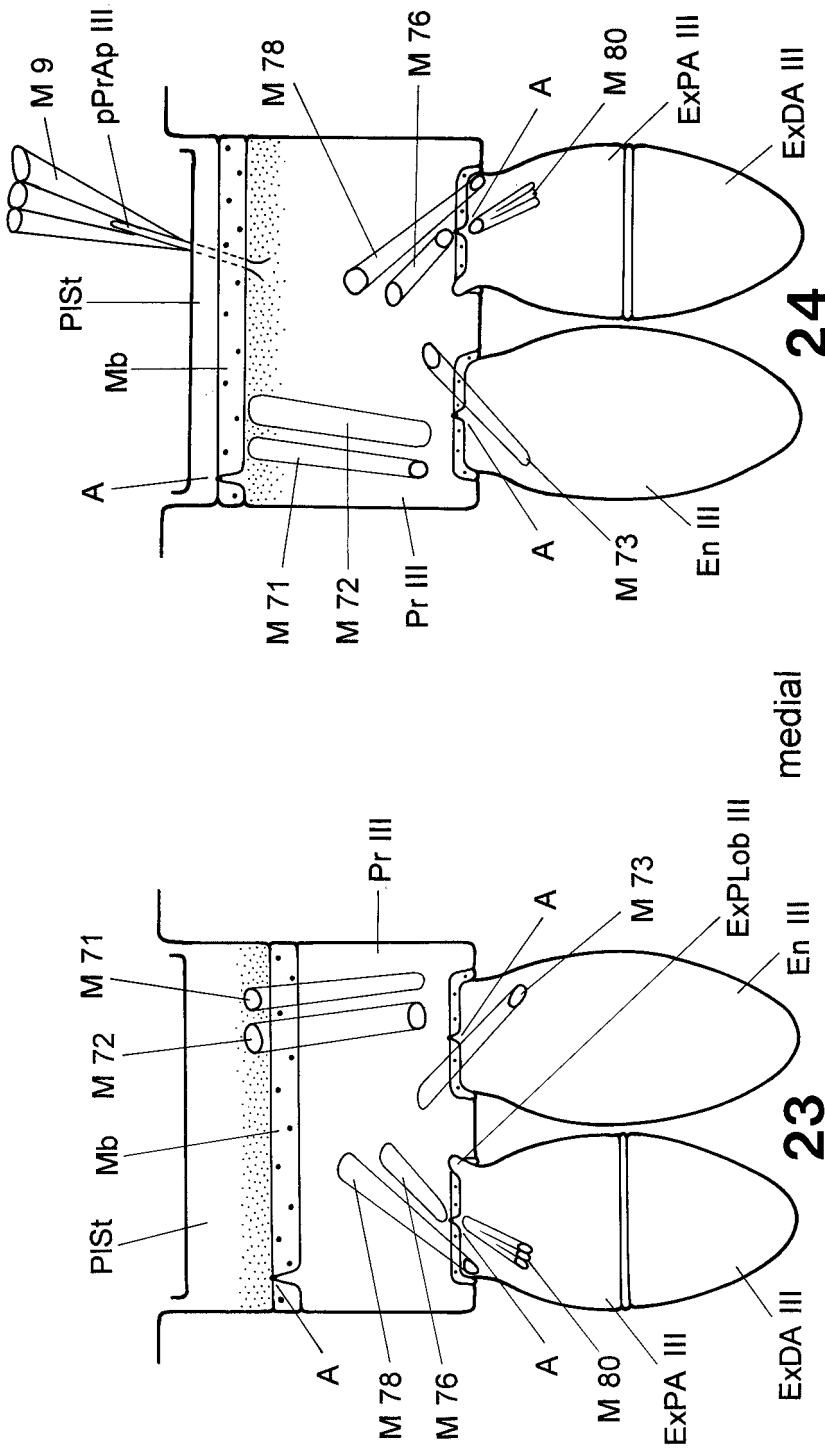

Figs. 23-24. Diagrams of the skeleton and musculature of the male pleopods III within the hypothetical groundpattern of the Asellota (compare with corresponding diagrams of the Phreatoicoidea and Oniscidea in ERHARD 1999; figs. 20-23). The pleopodal rami are projected onto the same level. Areas of former protopodite articles indicated by *compact dotting*, membranes by *bold single dots*. - 11. Anterior view; - 12. posterior view.

– Lateral pleopod epipodites

Within the phreatoicidean groundpattern as well as in *Tainisopus* large lateral epipodites on all five pleopod protopodites are present (ERHARD 1999: 29; WILSON & PONDER 1992). In the oniscidean groundpattern large lateral protopodal epipodites occur only at the pleopods I and II but are missing on the pleopods III–V (ERHARD 1995: 72). In the Asellota as well as in the Calabozoidea and the outgroup Tanaidacea conspicuous lateral pleopod epipodites could not be shown. Further out- and ingroup comparisons might serve to assess the polarity of this character.

– Coupling hooks and medial lobes

In the aselloidean genera *Asellus* and *Stenasellus* the pleopod protopodites I are connected by strong spines with hooks at their tips functioning as coupling facilities (figs. 1–6). In the non-aselloidean Asellota including *Vermectias* the pleopod protopodites I are fused. Thus, *Asellus* and *Stenasellus* represent a plesiomorphous status with free protopodites I. Coupling setae of the pleopod protopodites also occur for example in the isopodan taxa Phreatoicidea (pleopods I–V; cf. ERHARD 1999), *Tainisopus* (pleopods I–V; cf. WILSON & PONDER 1992) and further peracaridan groups like the isopodan sistergroup Tanaidacea (e.g. *Apseudes latreillii*; cf. ERHARD 1999: 32). Presumably, the presence of coupling setae with hooked tips in their general form might represent a plesiomorphy in respect to the isopodan groundpattern while their lack in all pleopods of the Oniscidea and Calabozoidea and the pleopods II–V of the Asellota then has to be considered as apomorphic (cf. ERHARD 1999: 32).

According to ERHARD (1999: 32) conspicuous medial lobes at the medial walls of the pleopod protopodites as bases for coupling setae might also represent a groundpattern character of the outgroup Tanaidacea and the isopodan taxa Phreatoicidea and *Tainisopus* (ERHARD 1999, WILSON & PONDER 1992). In the Oniscidea (cf. ERHARD 1995, 1996, 1997) and the Asellota corresponding structures are missing. In those cases where coupling spines are present in asellotan species (pleopods I in the Asellidae and Stenasellidae) no medial protopodite lobes occur (chapt. 4.1.1.1.).

– Articulations between pleopod protopodites and exopodites

Between the protopodites and exopodites dicondylic articulations are assumed to occur in the groundpatterns of the phreatoicidean pleopods I–V and the oniscidean pleopods III–V (cf. ERHARD 1999: 28). In the pleopods I–V of the Asellota (*Stenasellus costai*, *Asellus aquaticus*) dicondylic articulations between protopodites and exopodites occur as well. Presumably, the presence of monocondylic protopodite-exopodite articulations (oniscidean pleopods I–II) might be an apomorphic character state in respect to the isopodan groundpattern.

– Articles of the male pleopod exopodites

In certain isopodan groups as for example in the Phreatoicidea (cf. ERHARD 1999: 28), the Asellota and in the incertae-sedis group *Tainisopus* the male pleopod exopodites II–V are composed of two articles. In the groundpattern of the presumptive isopodan sistergroup Tanaidacea the pleopod exopodites I–V are biarticulate (e.g. *Apseudes latreillii*). The distal joints of the phreatoicidean pleo-

pod exopodites II–V and of the exopodites II and III of the asellotans *Stenasellus* and *Asellus* are clearly movable and interarticular membranes between both exopodite articles are developed. Additionally, between the proximal and distal exopodite III-articles of both asellotan genera conspicuous articular points could be shown (fig. 19).

The pleopod exopodites I of the Phreatoicidea and Asellota consist of a single article, a distal one is missing. This character of uniarticulate pleopod exopodites I is a common feature among the isopodan groups and might be an apomorphy of the taxon Isopoda while its presumptive sistergroup Tanaidacea (cf. TABACARU & DANIELOPOL 1999, KOBUSCH 1999) is still showing biarticulate exopodites I.

In the Oniscidea and Calabozoidea the pleopod exopodites I–V are always composed of one joint (ERHARD 1995: 72) which is an apomorphous character state in respect to the condition present in the Phreatoicidea, Asellota and the isopodan groundpattern (ERHARD 1999: 29).

WILSON & PONDER (1992: 295) assess the narrow articulation between the proximal and distal exopodite segments as an autapomorphous character state of the Phreatoicidea. Other isopodan groups with biarticulate pleopod exopodites as for example *Tainisopus* and the Asellota have broad articulation areas or suture lines between both joints which also can be observed in tanaidacean species (e. g. in *Apsuedes latreillii*).

– Proximal lobes of the pleopod exopodites

In most phreatoicidan species the proximal exopodite articles of the pleopods II–V have medioproximal and lateroproximal lobes (cf. ERHARD 1999: 29). In the asellotan species *Stenasellus costai* and *Asellus aquaticus* small proximal exopodite lobes of the pleopods III–V are present medially or laterally (figs. 18–19). In the oniscidean groundpattern comparable lobes could not be shown so far (cf. ERHARD 1995, 1996, 1997).

– Guiding lobes for the pleopod exopodites III–V

In all oniscidean species investigated so far the pleopod protopodites III–V have posterior sclerotized lobes which probably are guiding the exopodites III–V during their movements (ERHARD 1995, 1996, 1997). In contrast, in the Phreatoicidea (ERHARD 1999) as well as in the investigated asellotan species corresponding guiding lobes are missing for all pleopod exopodites.

4.4.2. Musculature

– Pass of the intrinsic pleopod promotor Mm 48, 58/59, 71/72

The pleopod promotor M 48, Mm 58/59 and Mm 71/72 of the Phreatoicidea, Calabozoidea and the outgroup Tanaidacea (*Apsuedes*) are stretched between the proximal and distal articles of the pleopod protopodites I–III (ERHARD 1999: figs. 4–5, 12–13, 20–21). In contrast, M 48, Mm 58/59 and Mm 71/72 in the Oniscidea (ERHARD 1999: figs. 6–7, 14–15, 22–23) and the investigated asellotan species (cf. chaps. 4.1.1.2., 4.2.1.2., 4.3.1.2.) take their origins at the anterior parts of the pleon sternites I–III because the anterior parts of the former proximal protopodite articles obviously fused to the sternites (cf. chapt. 4.4.1.). This assumption implies

apomorphous character states of the Oniscidea and Asellota in respect to the phreatoicidean, calabozoidean and tanaidacean conditions.

The intrinsic pleopod promotor M 48 (pleopod I), Mm 58/59 (pleopod II) and Mm 71/72 (pleopod III) of the investigated phreatoicidean species are composed of 2–4 main units (cf. ERHARD 1999: 32). The homologous muscles in the Oniscidea (cf. ERHARD 1995, 1996, 1997) and Asellota are formed by 1–2 units respectively.

- Pleopod endopodite locomotors Mm 47, 61, 73, 83, 91

In the tanaidacean *Apsedes latreillii*, the Phreatoicidea (e. g. *Metaphreatoicus australis*, cf. ERHARD 1999: figs. 1, 8, 17) and the Oniscidea (e. g. *Ligia*, *Tylos*, *Oniscus*, *Actaecia*, cf. ERHARD 1995) the endopodite locomotors within the pleopods I–V, Mm 47, 61, 73, 83, 91, arise on the anterior walls of the protopodites. The anteriorly located origin of M 73 within the pleopods III could also be observed in *Calabozoa pellucida*.

In contrast, the homologous muscles in the pleopods II–V of the asellotans *Stenasellus* and *Asellus* (pleopod endopodites I are missing in the Asellota) take their origins on the posterior protopodite walls (figs. 7–12, 18–24). The posterior located origin of M 61 could also be shown within the pleopods II of *Vermectias*. On account of this pattern of character states the asellotan condition might represent an apomorphous state in respect to the isopodan groundpattern.

- Interarticular protopodite muscles Mm 51/115/116, 64/119/120/122, 75/123/124/125

The protopodite muscles Mm 51, 115, 116 (pleopods I), Mm 64, 119, 120, 122 (pleopods II) and Mm 75, 123, 124, 125 (pleopods III) of the Phreatoicidea are stretched between the proximal and the distal protopodite articles (ERHARD 1999: figs. 4–5, 12–13, 20–21). An identical pass of corresponding muscles could be shown in the tanaidacean *Apsedes latreillii*. Within the groundpattern of the Oniscidea the muscles Mm 51, 64 and 75 of the pleopods I–III are present within the uniarticulate protopodites whereas the muscles Mm 115/116, 119/120/122, 123/124/125 are lacking (ERHARD 1999: figs. 6–7, 14–15, 22–23). Homologous branches to all above mentioned interarticular protopodite muscles could not be shown within the investigated asellotans *Stenasellus*, *Asellus* and *Vermectias* (cf. chaps. 4.1., 4.2., 4.3.).

The occurrence of two pleopod protopodite joints in the Phreatoicidea is interpreted by ERHARD (1999: 26) as an ancestral condition among isopods. Simultaneously, it has to be assumed that the oniscidean and asellotan protopodites, formed by only one joint respectively, originate by the fusion of the former proximal article with the sternite at its anterior side and with the distal protopodite joint at its posterior side. The lack of interarticular protopodite muscles in the Oniscidea and the Asellota then might be explained by secondary loss after the formation of an uniarticulate protopodite during evolution because the muscles cannot any longer function as locomotors between immovable articles. This scenario implies that the presence of the interarticular muscles in the Phreatoicidea and the Tanaidacea might represent a plesiomorphous state in relation to the apomorphous conditions in the Oniscidea and Asellota.

– Medial exopodite locomotors (Mm 53/56, 63/118, 76/79)

In the tanaidacean and isopodan groundpatterns the medial bases of the pleopod exopodites are moved by two medial exopodite locomotors per pleopod. One branch arises on the anterior wall of the distal protopodite article whereas the other bundle takes its origin on the posterior side of the proximal joint (compare for example the phreatoicidean pleopod II in ERHARD 1999: figs. 12–13). This pattern of the medial exopodite locomotors could exactly be shown in all pleopods of the tanaidacean *Apseudes latreillii*, however in several different derived conditions within the pleopods of the investigated isopodan taxa Phreatoicidea, Oniscidea and Asellota (figs. 5–6, 11–12 and 23–24; ERHARD 1999: figs. 4–7, 12–15 and 20–23). On account of these differences it appears difficult to homologize the retained medial exopodite locomotors of the Isopoda with certainty at the present state of knowledge. Therefore, a detailed character analysis and polarity assessment is abandoned within the present paper.

– Lateral exopodite locomotors (Mm 54/55, 65/66, 77/78)

Within the isopodan groundpattern, presumably two distinct lateral exopodite locomotors per pleopod are present (Mm 54/55, 65/66, 77/78 in the pleopods I–III, corresponding muscles occur also in the pleopods IV and V). Additionally, both exopodite locomotors of one pleopod have different points of origin that are the posterior and the anterior protopodite walls. This situation is existing within the outgroup Tanaidacea (*Apseudes latreillii*) and in the groundpatterns of the isopodan ingroups Oniscidea (pleopods I–V; cf. ERHARD 1995, 1996, 1997, 1999) and Asellota (pleopods I and II; figs. 1–2, 7–10)¹. In the Oniscidea this plesiomorphous condition is retained within the pleopods II–V of the Orthogonopoda (Mesoniscidae + Synocheta + Crinocheta, cf. ERHARD 1998b) and the pleopods I and II of *Ligia oceanica*.

In the Phreatoicidea also two distinct lateral exopodite locomotors are present, however, in all pleopods both muscles arise on the posterior protopodite wall (cf. ERHARD 1999: figs. 4–5, 12–13, 20–21). That condition has to be considered as an apomorphic status of the Phreatoicidea in respect to the isopodan groundpattern.

As mentioned above, the male pleopods I and II of *Stenasellus costai* and the pleopods II of *Vermectias nelladanae*² have two lateral exopodite locomotors with different points of origin at the posterior and the anterior protopodite walls. In contrast, the pleopods III of *Stenasellus* and *Asellus* show only one lateral exopodite locomotor M 78 whereas M 77 is lacking. A corresponding condition is present in the pleopods IV and V. This latter condition has to be considered as an apomorphic character state in respect to the isopodan groundpattern. While the pleopods II of *Asellus aquaticus* show exactly the plesiomorphous isopodan condition, the male pleopods I have reduced the posteriorly originating branch which

¹) Unfortunately, the figures 22 and 23 in ERHARD (1999) show an incorrect pass of the lateral exopodite locomotors within the groundpattern of the oniscidean pleopods III because the origin of the muscle M 77 is actually situated at the anterior protopodite wall instead of the posterior side misrepresented in the above mentioned figures.

²) In *Vermectias nelladanae* only the male pleopods II have fully developed proto-, exo- and endopodites including the corresponding musculature. The pleopods I and III–IV (pleopods V are missing) are strongly reduced in respect to the muscular equipment.

represents an apomorphous state of *Asellus* whereas *Stenasellus costai* still has both lateral exopodite locomotors Mm 54/55 (cf. chapt. 4.1.1.2., 4.2.1.2.).

– Intrinsic endopodite muscles Mm 117, 121, 126

The pleopods I–III within the groundpattern of the Phreatoicoidea (cf. ERHARD 1999: 36) bear one intrinsic endopodite muscle respectively (Mm 117, 121, 126). Serial homologa to these muscles also occur in the phreatoicoidean pleopods IV and V. In all pleopods of the tanaidacean *Apsendes latreillii* a muscle could be shown which arises distomedially on the anterior wall of the distal protopodite article running deeply into the endopodite. Probably, these muscles are homologous to the intrinsic endopodite muscles Mm 117, 121 and 126 of the Phreatoicoidea.

Within the Oniscidea (cf. ERHARD 1995, 1996, 1997, 1999) and the investigated asellotan species intrinsic endopodite muscles comparable to the tanaidacean and phreatoicoidean muscles are not existing.

5. Uropods

5.1. Asellotan species (figs. 25–27)

The uropodal skeleton and musculature of *Stenasellus costai* and *Asellus aquaticus* are more or less identical wherefore the anatomical description within this chapter is largely limited to the species *Asellus aquaticus*.

5.1.1. Skeleton

The styliform uropods of *Stenasellus costai* and *Asellus aquaticus* are inserted (sub-) terminally at the large pleotelson. Only the short telsonic shield is projected slightly over the bases of the uropod protopodites. Between these bases the terminal anus is situated (fig. 26; ERHARD 2001: figs. 1–5, 8–9).

In *Asellus aquaticus* the articular points between the pleotelson and the uropod protopodites are located ventrally and dorsally (fig. 26). The protopodites are movable in lateral and medial direction. The ventral articular point is strongly developed and clearly visible whereas the dorsal hinge appears very inconspicuous. The apophyses for the locomotors of the uropod protopodites Mm 97–100 are positioned dorsomedially (M 97) and ventromedially (M 98) as well as laterally (Mm 99, 100). In *Stenasellus costai* the lateral apophysis additionally is divided into a dorso-lateral (M 99) and ventrolateral branch (M 100).

The uropod protopodites of the investigated asellotan species show a subcircular sectional view and they are slightly flattened in the dorsoventral plane. Dorsal longitudinal ridges of the protopodites as present in the Phreatoicoidea (cf. ERHARD 1999: 46) do not occur in the asellotan species. At the uropod protopodite in *Asellus aquaticus* a basal suture is developed. At that suture the uropod protopodite can be torn off from the pleotelson which can often be observed in fixed specimens. This mechanism seems to be important as strategy against predators which grasp the uropods (cf. chapt. 5.2.).

The uropod exo- and endopodite are nearly the same size. Both rami are inserted distally on the protopodite. In *Asellus aquaticus* and *Stenasellus costai* the rami are

both uniarticulate. Between the uropod protopodite and the exo- and endopodite dicondylic articulations are developed. The articular points are located laterally and medially at the bases of the uropodal rami, wherefore they are movable in dorsal and ventral directions. The uropod exopodite basis has developed ventral and dorsal apophyses which serve as attachment points for the exopodite depressor M 101 and the levator M 102 (fig. 27). At the endopodite basis only a ventral apophysis is present whereon the endopodite depressor M 103 is inserted. As it is the case in all eumalacostracan species (cf. ERHARD 1995: 95) an endopodite levator does not exist in asellotan species.

5.1.2. Musculature

The uropodal muscles Mm 97–103 of *Asellus aquaticus*, described below, are homologous to the muscles Mm 97–103 of the Phreatoicoidea (cf. ERHARD 1999: 37) and the Oniscidea (cf. ERHARD 1995, 1996, 1997).

M 97: Moves the uropod protopodite in medial direction. Arises on the pleotelsonic tergite and is inserted on the dorsomedial apophysis of the uropod protopodite. Composed of a lateral strong bundle and a medial small branch.

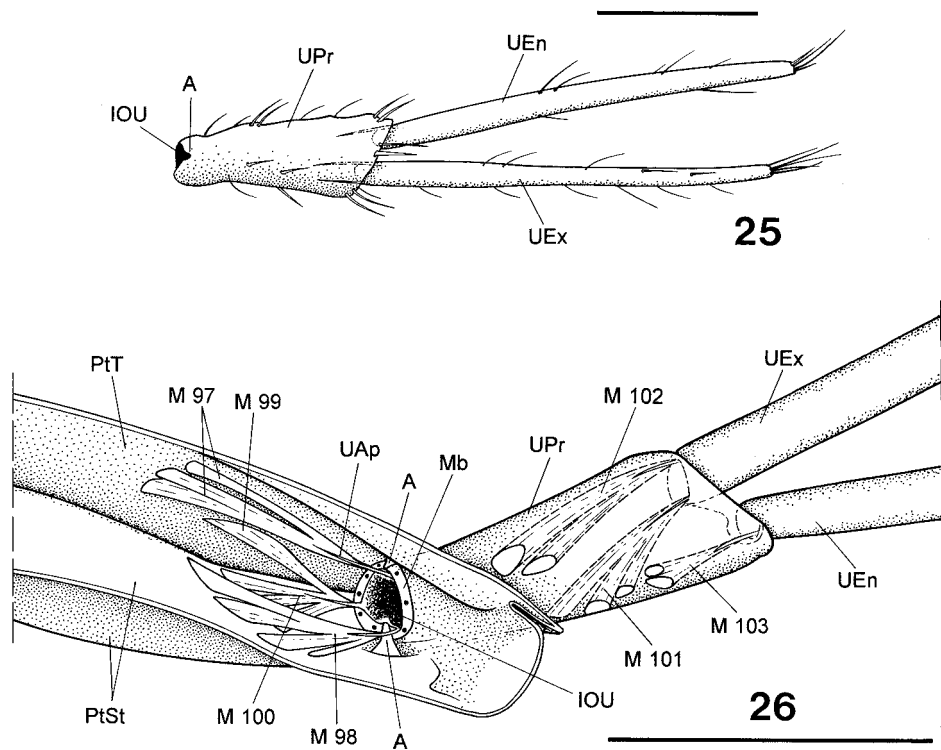

Figs. 25–26. *Asellus aquaticus*, ♂. – 25. Right uropod in ventrolateral view. – 26. Paramedian longitudinal section through the pleotelson in medial view showing the skeleton and musculature of the right uropod. – Scales: 1 mm.

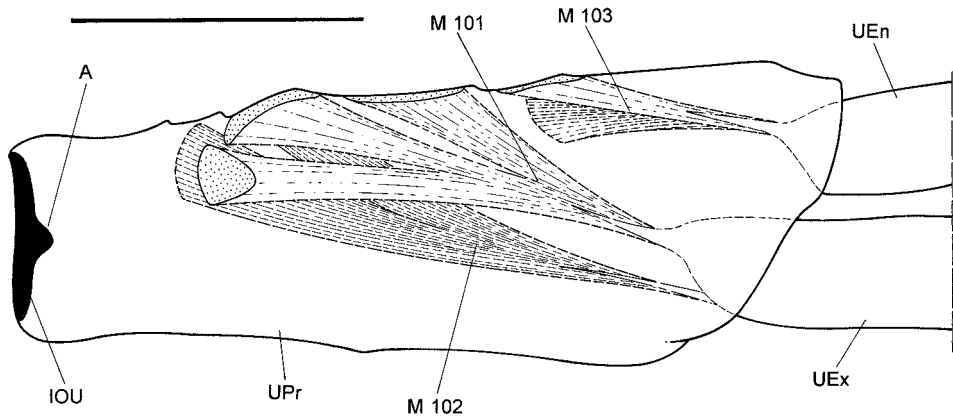

Fig. 27. *Asellus aquaticus*, ♂, right uropod protopodite in ventrolateral view. – Scale: 0,5 mm.

M 98: Moves the uropod protopodite in medial direction. Arises on the pleotelsonic sternite and is inserted on the ventromedial apophysis of the uropod protopodite. Composed of three lateral strong bundles and one medial small branch.

M 99: Moves the uropod protopodite in lateral direction. Arises on the pleotelsonic tergite and is inserted together with M 100 on the lateral apophysis of the uropod protopodite. Composed of one bundle.

M 100: Moves the uropod protopodite in lateral direction. Arises on the pleotelsonic sternite and is inserted together with M 99 on the lateral apophysis of the uropod protopodite. Composed of three short bundles.

M 101: Depressor of the uropod exopodite. Arises proximally to M 103 on the medial and ventral wall of the uropod protopodite and is inserted on the ventral apophysis of the uropod exopodite. Composed of three bundles. M 101 is located between M 102 and M 103.

M 102: Levator of the uropod exopodite. Arises medially on the dorsal wall of the uropod protopodite and is inserted on the dorsal apophysis of the uropod exopodite. Composed of two bundles.

M 103: Depressor of the uropod endopodite. Arises distally on the medial wall of the uropod protopodite and is inserted on the ventral apophysis of the uropod endopodite. Composed of two short bundles.

5.2. Comparison (figs. 28–29)

– Insertion area of the uropods

According to ERHARD (1999: 40) the anteriolateral insertion of the uropods on the pleotelson in the groundpattern of the Phreatoicidea might be a plesiomorphic character state among isopods. It can also be observed in fossil phreatoicidians like *Hesslerella shermani* from the upper Carboniferous (cf. SCHRAM 1974: fig. 3).

This primitive status also has to be assumed for other peracaridan groups like the presumptive isopodan sistergroup Tanaidacea as reconstructed by SIEG (1984:

fig. 5). In the fossil tanaidaceans *Anthracocaris* and *Cryptocaris* the uropods were inserted laterally on the free pleonite VI which was located posteriorly to the telson (SCHRAM 1974: fig. 10, SIEG 1983: fig. 2, 1984: 36, 80).

In contrast, the terminal insertion of the uropods at the pleotelson, present for example in the Oniscidea (cf. ERHARD 1999: fig. 29) and the Asellota (fig. 28), is assumed to be an apomorphic condition in respect to the isopodan groundpattern (WÄGELE 1994: 93).

– Condition of the uropodal articular points

In the Oniscidea (e. g. *Ligia oceanica*, cf. ERHARD 1995: 86) as well as in the investigated asellotan species *Asellus aquaticus* and *Stenasellus costai* the ventral articular point between pleotelson and uropod protopodite is developed very strikingly with a prominent condylus whereas the dorsal hinge is nearly undiscernible. In contrast, in the Phreatoicidea both articular points can easily be observed and a special strengthening of the ventromedial hinge is not present (cf. ERHARD 1999: figs. 24–25).

– Suture of the uropod protopodite basis

In basal species of the Oniscidea (*Ligia oceanica*, cf. ERHARD 1995: 86) and the Asellota (*Asellus aquaticus*, cf. chapt. 5.1.1.) a suture of the uropod protopodite could be shown at which the protopodite can be torn off from its basis. This could be often observed in fixed specimens and might be a part of a strategy against predators which clutch at the uropodal rami. In such a “tear off” situation the most proximal part of the protopodite including its apophyses for the extrinsic locomotors remains at the pleotelson and thus is still available for regeneration of the uropod. However, in the asellotan species *Stenasellus costai* as well as in the Phreatoicidea (cf. ERHARD 1999) such a mechanism could not be observed so far.

– Arrangement of the uropodal muscles and articular points

According to ERHARD (1999: 44) the skeletal and muscular units of the uropods in eumalacostracan groups can easily be homologized. However, differences occur which concern the spatial arrangement of the uropodal articular points and the musculature.

Within the oniscidean groundpattern as well as in the tanaidacean *Apsedes latreillii* the uropod protopodites are movable in lateral and medial direction on account of a dorsoventral articular axis (cf. fig. 29; ERHARD 1995, 1996, 1997) which might represent the plesiomorphous character state in respect to the isopodan groundpattern. The apophyses of the protopodite locomotors (Mm 97–100) e. g. in the basal oniscid *Ligia oceanica* are situated laterally (Mm 99, 100) as well as mediodorsally (M 97) and medioventrally (M 98). The asellotan species *Asellus aquaticus* shows a completely identical condition (fig. 26). Also the muscles Mm 97–100 are composed and arranged in both species in a conspicuously similar manner and correspond, moreover, to the situation present in the asellotans *Stenasellus* and *Vermectias* as well as in the tanaidacean *Apsedes latreillii* (figs. 28–29; ERHARD 1999: fig. 29).

In contrast, the uropod protopodites within the phreatoicidean groundpattern are movable in dorsomedial and ventrolateral directions. The articular points between pleotelson and uropod protopodite are forming an axis which passes from

Asellota (Isopoda)

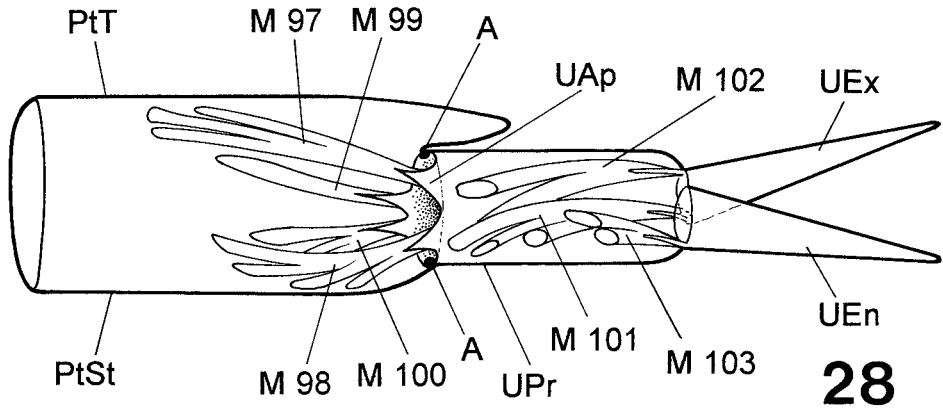
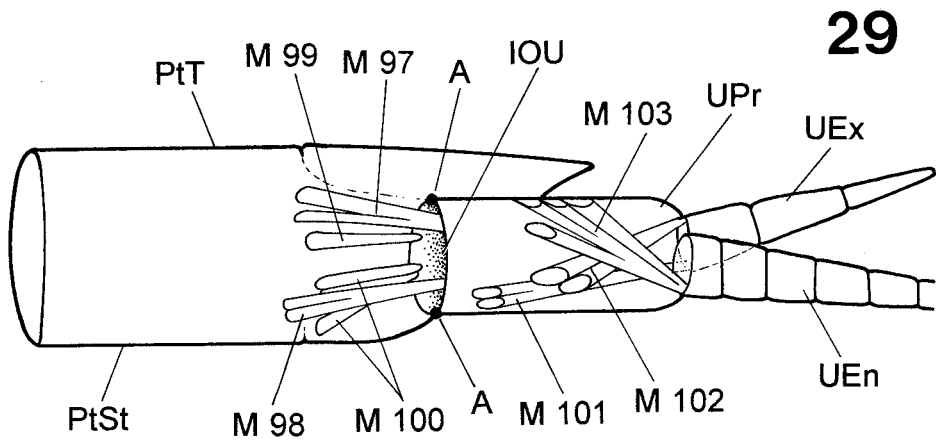
*Apseudes* (Tanaidacea)

Figs. 28–29. Diagrams of the skeleton and musculature of the uropods in the Asellota and Tanaidacea in medial view (compare with corresponding diagrams of the Phreatoicidea and Oniscidea in ERHARD 1999: figs. 28–29). – 28. Hypothetical groundpattern Asellota (Isopoda); – 29. *Apseudes latreillii* (Tanaidacea).

ventromedial to lateral. Only two protopodite apophyses are developed which are situated ventrolaterally and dorsomedially. The muscles Mm 97–100 are strongly developed and fan-shaped arising on the anterior lateroventral pleotelsonic extensions present in most phreatoicideans (cf. ERHARD 1999: figs. 25–26, 28). Presumably, these pleotelsonic extensions as well as the muscular and articular arrangements are corresponding to the formation of the phreatoicidean pleopodal chamber which is assumed to be an apomorphic character state of the Phreatoicida (cf. ERHARD 1999: 42). Therefore, the spatial muscular and articular arrangement of the phreatoicidean uropods also might partly represent derived conditions in respect to the situation for example in the Oniscidea and the Asellota (cf. ERHARD 1999: 44).

– Composition of the uropod muscles Mm 97 and 99

The fan-shaped uropod protopodite locomotors Mm 97 and 99 of the Phreatoicida are strongly developed and consist of more than 6 branches respectively (cf. ERHARD 1999: figs. 24–25, 28). In contrast, the homologous muscles of the Oniscidea (cf. ERHARD 1995, 1996, 1997, 1999: fig. 29) and the investigated asellotans *Asellus*, *Stenasellus* and *Vermectias* (figs. 26, 28) as well as corresponding muscles of the tanaidacean *Apsudes* (fig. 29) are composed of maximum 3 bundles. The latter condition might represent the plesiomorphic condition in respect to the isopodan groundpattern.

– Arrangement of the uropodal locomotors Mm 101–103

Within the uropod protopodite of the Phreatoicida the uropod exopodite depressor M 101 is situated laterally to the muscles M 102 and M 103 (cf. ERHARD 1999: fig. 28). A corresponding condition could be shown in the tanaidacean species *Apsudes latreillii* (fig. 29). In the Oniscidea (cf. ERHARD 1995, 1996, 1997, 1999: fig. 29) and in the investigated asellotans *Asellus*, *Stenasellus* and *Vermectias* (fig. 28) M 101 always runs between the muscles M 102 and M 103. Probably, the latter condition has to be considered as an apomorphy in respect to the isopodan groundpattern.

6. Conclusions

6.1. Groundpattern characters

6.1.1. Pleopods I

The lack of the male pleopod endopodite I including its musculature (M 47) represents an autapomorphy of the taxon Asellota because the male pleopods I in the isopodan groundpattern as well as in most isopodan groups are biramous (chapt. 4.1.2.).

The complete reduction of the female pleopod I in the Asellota represents an autapomorphy of the group. Within the isopodan groundpattern biramous female pleopods I are present (chapt. 4.1.2.).

6.1.2. Skeleton of the pleopods II

The male pleopod endopodite II in the isopodan groundpattern is divided into a mediobasal appendix masculina and a proximal leaflike joint. In contrast, the complete reduction of the laterobasal respiratory and locomotory part of the proximal male endopodite II-article, the broadening of this proximal joint and the resulting geniculate (knee-like) form of the gonopod in the Oniscidea and Asellota have to be considered as apomorphic conditions (chapt. 4.2.2.).

The enlargement of the male proximal endopodite II article and the formation of a sperm tube as well as the transformation of the distal endopodite II joint (appendix masculina) into a medial spur (processus calcariformis) have to be considered as apomorphic features of *Asellus* and related genera in respect to the asellotan groundpattern (chapt. 4.2.1.1.).

The presence of uniarticulate pleopod endopodites II and the lack of respiratory and locomotory lateral parts in male specimens of *Tainisopus* and the Calabozoidea are scored as derived features in respect to the isopodan groundpattern (chapt. 4.2.2.).

In the phreatoicidan, oniscidean and asellotan groundpatterns a dicondylic articulation is present between the proximal endopodite II-article and the appendix masculina (chapt. 4.2.2.).

Within the oniscidean groundpattern the appendices masculinae have linear shapes whereas the distal parts of the gonopods in the Phreatoicida, Calabozoidea, *Tainisopus* and most asellotan groups are curved or are directed laterally. A cooperation of both appendices masculinae during copulation, presumably, represents a groundpattern character of the Oniscidea which is not confirmed for the Phreatoicida, Calabozoidea, Asellota and *Tainisopus* (chapt. 4.2.2.).

In the isopodan groundpattern the anteriodistal wall of the appendix masculina is deepened, forming a channel for the distally directed transport of spermatophores. This sperm groove is retained at least in the Phreatoicida, Calabozoidea, Asellota, Oniscidea, Valvifera and *Tainisopus* (chapt. 4.2.2.).

The presence of an interlocking mechanism between the male pleopod endopodite and exopodite II might represent an autapomorphic character state of the Asellota (chapt. 4.2.2.).

The complete reduction of the female pleopod endopodite II represents an autapomorphy of the Asellota. In contrast, the female pleopod endopodite II is still present e. g. in the Oniscidea, Phreatoicida, Calabozoidea and *Tainisopus* (chapt. 4.2.2.).

In the Phreatoicida and in *Tainisopus* the male as well as the female pleopod exopodite II is composed of two articles which might represent the plesiomorphic character state in respect to the isopodan groundpattern. While the male pleopod exopodite II of the Asellota consists still of two articles, the female exopodite II is only uniarticulate which, presumably, might be an autapomorphic condition of the Asellota (chapt. 4.2.2.).

6.1.3. Musculature of the pleopods II

In the tanaidacean *Apseudes latreillii*, the Phreatoicida and some asellotan groups (e. g. *Stenasellus*, *Asellus*) only one locomotor of the male pleopod endopodite II, M 61, is present whereas in the oniscidean groundpattern and, probably, in certain asellotan taxa (e. g. *Stenetrium*, *Jaera*) two antagonistic locomotors (Mm 60 and 61)

are developed. The latter conditions might represent apomorphic states in respect to the isopodan groundpattern, presumably developed convergently in the groups Oniscidea and Asellota (chapt. 4.2.2.).

The presence of the muscle M 62 serving as locomotor of the appendix masculina is assumed to be a groundpattern character of the Phreatoicoidea, Oniscidea and Asellota (chapt. 4.2.2.).

The enlargement of the male pleopod exopodite II-muscles Mm 65/66 for special copulatory purposes has to be considered as an autapomorphy of the Asellota in comparison with the plesiomorphous "normal" condition present for example in the Phreatoicoidea and Oniscidea (chapt. 4.2.2.).

The transformation of the pleopod exopodite II-locomotor M 67 to an interarticular locomotor of the distal pleopod exopodite II-article represents an autapomorphic status of the Asellota (chapt. 4.2.2.).

6.1.4. Pleopods III

Opercular pleopod exopodites III which are covering the pleopod endopodites III as well as the pleopods IV–V and which are forming a ventral pleopodal chamber below the pleotelsonic ventrum have to be regarded as an autapomorphic character of the Asellota (chapt. 4.3.2.).

6.1.5. Skeleton of the pleopods I–V

The pleopod protopodites I–V of the Tanaidacea (*Apsendes*) and the isopodan taxa Phreatoicoidea and Calabozoidea are formed by two joints respectively which might be a plesiomorphous situation in respect to the taxa Asellota and Oniscidea whose protopodites consist only of one article. Concerning the position of the apophyses of the extrinsic protopodite remoters, the presence of a conspicuous membrane between the sternites and the anterior protopodite walls as well as the articulation between protopodites and sternites the conditions of the Oniscidea and Asellota are exactly corresponding (chapt. 4.4.1.).

The presence of small male pleopods I and II in comparison with the pleopods III–V has to be considered as an apomorphic groundpattern character of the Asellota. In the isopodan groundpattern as well as in the Phreatoicoidea and Oniscidea all pleopods are nearly the same size (chapt. 4.4.1.).

The presence of feathered or hooked coupling setae on the medial walls of the pleopod protopodite articles might be a groundpattern character of the presumptive sistergroup Tanaidacea and Isopoda (cf. Phreatoicoidea, *Tainisopus*). Corresponding structures are also present on the pleopod protopodites I in the Asellota but are missing in the asellotan pleopods II–V and in all pleopods of the Oniscidea and Calabozoidea which might represent apomorphic conditions (chapt. 4.1.2.).

The presence of lateral epipodites at all five pleopod protopodites represents a groundpattern character of the Phreatoicoidea and *Tainisopus*. In the oniscidean groundpattern large lateral epipodites of the pleopods I–II are present but epipodites lack on the pleopods III–V as well as on all pleopod protopodites of the Asellota and Calabozoidea (chapt. 4.4.1.).

The existence of dicondylic articulations between the pleopod protopodites and endopodites I–V and the presence of sclerotized basal endopodite regions are as-

sumed to be plesiomorphous conditions in respect to the isopodan groundpattern. These are retained in the phreatoicidean pleopods I–V, the asellotan pleopods II–V and the oniscidean pleopods II. A reduction of articular points between protopodites and endopodites and the lack of sclerotized basal endopodite regions then has to be interpreted as apomorphous character states which are present at least in the oniscidean pleopods III–V (chapt. 4.4.1.).

Within the isopodan, phreatoicidean and asellotan groundpatterns dicondylic articulations between all pleopod protopodites and exopodites occur. In the oniscidean groundpattern dicondylic articulations between protopodites and exopodites are present in the pleopods III–V. However corresponding hinges in the pleopods I–II are monocondylic which might be an apomorphous status (chapt. 4.4.1.).

Within the isopodan, phreatoicidean and asellotan groundpatterns the male pleopod exopodites II–V are composed of two articles. The distal joints of the phreatoicidean exopodites II–V and the asellotan exopodites II–III are still movable and partially are connected with the proximal joint by true articular points (asellotan exopodite III). In the Oniscidea and Calabozzoidea all exopodites consist of one article which might represent an apomorphous condition in respect to the isopodan groundpattern. In the Phreatoicidea the articulation between both segments is narrow. Following WILSON & PONDER (1992: 295) this condition might be an autapomorphous character state of the group. An apomorphous groundpattern character of the Isopoda might be the existence of an uniarticulate pleopod exopodite I while the outgroup Tanaidacea still has retained biarticulate exopodites I–V (chapt. 4.4.1.).

The presence of posterior lobes of the pleopod protopodites III–V for guiding the pleopod exopodites III–V, presumably represents an apomorphous character state of the Oniscidea in respect to the Phreatoicidea and Asellota (chapt. 4.4.1.).

6.1.6. Musculature of the pleopods I–V

In the Phreatoicidea, Calabozzoidea and Tanaidacea the intrinsic pleopod promoters (M 48, Mm 58/59, Mm 71/72 within the pleopods I–III) are stretched between the proximal and distal pleopod protopodite articles (equivalent conditions could be shown in the pleopods IV–V). In the Oniscidea and the Asellota the homologous muscles run between the sternites and the pleopod protopodites which represents apomorphous states in respect to the tanaidacean and isopodan groundpatterns (chapt. 4.4.2.).

In the tanaidacean *Apsudes latreillii*, the investigated phreatoicidean species, *Calabozoa pellucida* and in the groundpattern of the Oniscidea the endopodite locomotors of the pleopods II–V (Mm 61, 73, 83, 91) arise on the anterior protopodite walls whereas in the investigated asellotan species the homologous muscles originate on the posterior protopodite sides. The latter character state has to be assumed as apomorphous in respect to the isopodan groundpattern (chapt. 4.4.2.).

In the tanaidacean and isopodan groundpatterns the medial bases of the pleopod exopodites are moved by two medial exopodite locomotors per pleopod (Mm 53/56, 63/118, 76/79 in the pleopods I–III). One branch arises on the anterior wall of the distal protopodite article whereas the other bundle takes its origin on the posterior side of the proximal joint (chapt. 4.4.2.).

The tanaidacean and isopodan groundpatterns include two lateral exopodite locomotors per pleopod with distinct points of origin at the posterior and anterior pro-

topodite walls (e. g. Mm 54/55, 65/66, 77/78 in the pleopods I–III). However, in the isopodan taxon Phreatoicidea both lateral exopodite locomotors arise on the same side that is the posterior protopodite wall which might represent an autapomorphic condition of the group. In the Asellota the pleopods III–V have only one lateral exopodite locomotor which also has to be assumed as the derived status (chapt. 4.4.2.).

The presence of interarticular protopodite muscles (Mm 51/115/116, 64/119/120/122, 75/123/124/125 within the pleopods I–III) represents a plesiomorphic groundpattern character of the Phreatoicidea which is also present in the outgroup Tanaidacea. The lack of the muscles Mm 115/116, 119/120/122, 123/124/125 in the Oniscidea and the complete lack of all interarticular protopodite muscles in the Asellota might be explained by secondary reduction (chapt. 4.4.2.).

The pleopods I–III of the Phreatoicidea have intrinsic endopodite muscles (Mm 117, 121, 126) which probably are homologous to intrinsic endopodite locomotors of the Tanaidacea. Within the Oniscidea and the Asellota comparable muscles could not be shown (chapt. 4.4.2.).

6.1.7. Skeleton of the uropods

The anteriolateral insertion of the uropods at the pleotelson of the Phreatoicidea is assumed to be a plesiomorphic character state in respect to the isopodan groundpattern. The terminal insertion present in the Oniscidea and Asellota, presumably, might be an apomorphic condition (chapt. 5.2.).

In the oniscidean and asellotan groundpatterns as well as in the tanaidacean *Apseudes* a dorsoventral articular axis is developed between pleotelson and uropod protopodite whereas in the Phreatoicidea the corresponding articular axis passes from ventromedial to lateral which might represent an apomorphic condition (chapt. 5.2.).

In the investigated oniscidean and asellotan species the ventral articular point between pleotelson and uropod protopodite is developed very striking while the dorsal hinge is nearly undiscernible. In the Phreatoicidea both articular points are equally developed (chapt. 5.2.).

6.1.8. Musculature of the uropods

In a strictly corresponding manner the uropod protopodite locomotors Mm 97–100 of the Oniscidea and Asellota are arranged distally within the pleotelson. In the Phreatoicidea the strongly developed and fan-shaped homologous muscles are located inside the anteriolateral pleotelsonic extensions which, presumably, might represent an apomorphic character state (chapt. 5.2.).

Within the phreatoicidean groundpattern the uropod locomotors M 97 and M 99 are strongly developed and consist at least of 6 bundles. The powerful and presumably apomorphic condition of the muscles might be explained by their function as part of the motor for the pleotelsonic thrusts (ERHARD 1999: 47, 48). The homologous muscles of the Oniscidea, Asellota and the tanaidacean *Apseudes* are composed of maximum 3 branches which might be a plesiomorphic character state (chapt. 5.2.).

Within the phreatoicidean groundpattern and in the tanaidacean species *Apseudes latreillii* the uropod exopodite depressor M 101 is situated laterally to Mm 102 and

103. In the Oniscidea and the Asellota M 101 always runs between the muscles M 102 and M 103. This latter situation, probably, has to be considered as an apomorphic status in respect to the isopodan groundpattern (chapt. 5.2.).

6.2. Apomorphies

Within part 2 of the present publication series (ERHARD 1999: 53) some presumptive apomorphic characters as well as anatomical features with uncertain polarity of the isopodan taxa Phreatoicidea and Oniscidea are listed. The paper in hand provides further information on the anatomy of the pleopods and uropods especially of the taxon Asellota. These new data supplement the knowledge on the pleopodal anatomy of the above mentioned isopodan groups and reveal further presumptive apomorphies in respect to the isopodan groundpattern described below. These characters complete the list of apomorphies presented in ERHARD (1999: 53).

It is emphasized that these new results only can represent the current state of knowledge. A final and comprehensive phylogenetical analysis of the pleonal characters described within the parts 1–4 of this publication series will be mainly the subject of a following fifth paper. This will include further in- and outgroup comparisons and a detailed discussion of the phylogenetic relationships of the taxa Phreatoicidea, Oniscidea, Asellota and further isopodan groups.

6.2.1. Phreatoicidea

Presumptive autapomorphies of the Phreatoicidea which might substantiate the monophyly of the group are the narrow articulation between the exopodite joints of the pleopods II–V (chapt. 4.4.1.), the formation of a ventral pleopodal chamber by downward developed pleon epimera, anterior lateroventral pleotelsonic extensions, laterally flattened uropod protopodites, the dorsally curved pleotelsonic apex as well as the adjacent regions of the caudal pleotelsonic margin (chapt. 5.2.) and the origin of the uropod protopodite locomotors Mm 97–100 at the side-walls of the anterior lateroventral pleotelsonic extensions (chapt. 5.2.).

The presence of the following presumptive apomorphies of the Phreatoicidea in other isopodan taxa still has to be checked by further ingroup comparisons: The origin of both lateral pleopod exopodite locomotors on the posterior protopodite wall within all pleopods (chapt. 4.4.2.), the position of the uropodal articular points forming an axis which passes from ventromedial to lateral (chapt. 5.2.) and the composition of the uropod protopodite locomotors Mm 97 and 99 which are formed in the Phreatoicidea by more than 6 strong branches respectively while in the Oniscidea, Asellota and in the tanaidacean *Apseudes* the muscles are composed of maximum three bundles (chapt. 5.2.).

6.2.2. Oniscidea/Asellota

The following presumptive apomorphies in respect to the isopodan groundpattern are present in the oniscidean as well as in the asellotan groundpattern. It has to be tested by further ingroup comparisons whether these derived characters occur also in other isopodan groups: The absence of the distal leaflike part of the proximal pleopod endopodite II-article in male specimens as well as the broadening of this

proximal joint and the resulting knee-like form of the male endopodite II (chapt. 4.2.2.), the presence of uniarticulate pleopod protopodites, the position of the apophyses of the extrinsic pleopod remoters, the existence of a conspicuous anterior membrane and a specific articulation between sternites and pleopod protopodites (chapt. 4.4.1.), the pass of the intrinsic pleopod promoters M 48, Mm 58/59, Mm 71/72 (pleopods I–III) which are stretched between the sternites and the protopodites (chapt. 4.4.2.), the terminal insertion of the uropods at the pleotelson (chapt. 5.2.), as well as the spatial arrangements of the uropod exo- and endopodite locomotors Mm 101–103 (chapt. 5.2.).

6.2.3. Oniscidea

The presence of the following presumptive apomorphies of the Oniscidea in other isopodan taxa still has to be checked by further ingroup comparisons: The complete linear shape of the appendices masculinae and the functional cooperation of the appendices of both sides (chapt. 4.2.2.), the existence of two locomotors of the male pleopod endopodite II, Mm 60 and 61, which are probably also present in some derived asellotan groups (chapt. 4.2.2.), the reduction of articular points between the pleopod protopodites and endopodites III–V and the lack of sclerotized basal endopodite regions in the pleopods III–V (chapt. 4.4.1.), the lack of medial hooked setae on all pleopod protopodites (chapt. 4.4.1.), the existence of monocondylic articulations between the protopodites and exopodites of the pleopods I and II (chapt. 4.4.1.), the presence of uniarticulate pleopod exopodites II–V (chapt. 4.4.1.), the presence of posterior lobes of the pleopod protopodites III–V for guiding the pleopod exopodites III–V (chapt. 4.4.1.) and the lack of the interarticular pleopod protopodite muscles Mm 115/116, 119/120/122 and 123–125 within the pleopods I–III (chapt. 4.4.2.).

6.2.4. Asellota

Presumptive autapomorphies of the Asellota which might substantiate the monophyly of the group are the complete reduction of the male pleopod endopodite I (chapt. 4.1.2.), the complete reduction of the female pleopod I (chapt. 4.1.2.), the complete reduction of the female pleopod endopodite II (chapt. 4.2.2.), the presence of uniarticulate female pleopod exopodites II (chapt. 4.2.2.), the interlocking mechanism between the male pleopod endopodite and exopodite II (chapt. 4.2.2.), the enlargement of the lateral pleopod exopodite II-locomotors Mm 65/66 in male specimens (chapt. 4.2.2.), the modification of M 67 as a locomotor of the distal pleopod exopodite II-article in male specimens (chapt. 4.2.2.), the operculate pleopod exopodite III (chapt. 4.3.2.), the size of the pleopods I and II which are clearly smaller than the pleopods III–V (chapt. 4.4.1.) as well as the posterior points of origin of the endopodite locomotors M 61, 73, 83, 91 within the pleopods II–V (chapt. 4.4.2.).

The presence of the following presumptive apomorphies of the Asellota in other isopodan taxa still has to be checked by further ingroup comparisons: The lack of medial hooked setae on the pleopod protopodites II–V (chapt. 4.4.1.), the lack of the interarticular pleopod protopodite muscles Mm 51/115/116, 64/119/120/122 and 75/123–125 within the pleopods I–III (chapt. 4.4.2.) and the presence of only one lateral pleopod exopodite locomotor within the pleopods III–V (chapt. 4.4.2.).

6.2.5. Characters of uncertain polarity

In case of several characters of the phreatoicidean, oniscidean and asellotan pleonal limbs the polarity of the different states still has to be determined by in- and out-group comparisons. These characters concern the presence of lateral pleopodal epipodites in the Phreatoicoidea, *Tainisopus* and the Oniscidea and their lack in the taxa Asellota and Calabozoidea (chapt. 4.4.1.), the existence of intrinsic endopodite muscles within all pleopods of the Phreatoicoidea (e. g. Mm 117, 121 and 126 within the pleopods I–III) and the lack of comparable muscles in the Oniscidea and the Asellota (chapt. 4.4.2.) as well as the differences in relation to the development of the articular points between the pleotelson and the uropod protopodite (chapt. 5.2.).

7. Acknowledgments

I wish to thank Dr. H. SCHMALFUSS (SMNS) for the loan of isopod material, helpful discussions and suggestions to improve an earlier draft of the manuscript as well as Dr. S. TAITI and Dr. G. MESSANA (Florence, Italy) for the donation of specimens of *Stenasellus costai*. For the donation of specimens of *Calabozoa pellucida* I thank Prof. Dr. J.-W. WÄGELE (Bochum) and for the generous supply of *Vermectias nelladanae* and *Phreatoicopsis terricola* I am thankful to Dr. G. C. B. POORE and Dr. E. WALLIS (NMV). Thanks are also due to Dr. G. D. F. WILSON and Dr. S. J. KEABLE (AM), Dr. M. van der MERVE, Dr. M. CLUVER (SAM) and Dr. T. ROY (Calcutta, India) for the donation of phreatoicidean species. Financial support was provided by the Deutsche Forschungsgemeinschaft (DFG-Forschungsstipendium Er 277/2–1).

8. References

- BRUSCA, R. C. & WILSON, G. D. F. (1991): A phylogenetic analysis of the Isopoda with some classificatory recommendations. – Mem. Queensld Mus. **31**: 143–204; Brisbane.
- CANNON, H. G. (1937): A new biological stain for general purposes. – Nature **139**: 549; London.
- CLAUS, C. (1884): Über *Apsedes latreillii* Edw. und die Tanaiden. – Arb. zool. Inst. Univ. Wien **5**: 319–332; Vienna.
- ERHARD, F. (1995): Vergleichend- und funktionell-anatomische Untersuchungen am Pleon der Oniscidea (Crustacea, Isopoda). Zugleich ein Beitrag zur phylogenetischen Systematik der Landasseln. – Zoologica **145**: 1–114; Stuttgart.
- (1996): Das pleonale Skelet-Muskel-System und die phylogenetisch-systematische Stellung der Familie Mesoniscidae (Isopoda: Oniscidea). – Stuttgarter Beitr. Naturk. (A) **538**: 1–40; Stuttgart.
 - (1997): Das pleonale Skelet-Muskel-System von *Titanethes albus* (Synocheta) und weiterer Taxa der Oniscidea (Isopoda), mit Schlußfolgerungen zur Phylogenie der Landasseln. – Stuttgarter Beitr. Naturk. (A) **550**: 1–70; Stuttgart.
 - (1998a): Morphological and phylogenetical studies in the Isopoda (Crustacea). Part 1: The pleon trunk in the Phreatoicoidea. – Stuttgarter Beitr. Naturk. (A) **581**: 1–42; Stuttgart.
 - (1998b): Phylogenetic relationships within the Oniscidea (Crustacea, Isopoda). – Isr. J. Zool. **44**: 303–309; Jerusalem.
 - (1999): Morphological and phylogenetical studies in the Isopoda (Crustacea). Part 2: The pleopods and uropods in the Phreatoicoidea. – Stuttgarter Beitr. Naturk. (A) **597**: 1–56; Stuttgart.
 - (2001): Morphological and phylogenetical studies in the Isopoda (Crustacea). Part 3: The pleon trunk in the Asellota. – Stuttgarter Beitr. Naturk. (A) **623**: 1–45; Stuttgart.
- GRUNER, H.-E. (1993): Crustacea. – In: KAESTNER, A.: Lehrbuch der Speziellen Zoologie 1, Teil 4: Arthropoda (ohne Insecta): 448–1030; Jena, Stuttgart & New York (G. Fischer Verlag).
- HENNIG, W. (1966): Phylogenetic systematics. – 263 pp.; Urbana, Chicago & London (Univ. Illinois Press).

- JUST, J. & POORE, G. C. B. (1992): Vermectiadae, a new primitive asellote isopod family with important phylogenetic implications. – *J. crust. Biol.* **12**: 125–144; Lawrence.
- KINNE, O. (1954): Eidonomie, Anatomie und Lebenszyklus von *Sphaeroma hookeri* Leach (Isopoda). – *Kieler Meeresforsch.* **10**: 100–120; Kiel.
- KOBUSCH, W. (1999): The phylogeny of the Peracarida (Crustacea, Malacostraca). Morphological investigations of peracaridan foreguts, their phylogenetic implications, and an analysis of peracaridan characters. – Vol. 1 & 2: 277 pp.; Göttingen (Cuvillier Verlag).
- KRAUTER, D. (1980): Ein rasch arbeitendes, schonendes Mazerationsmittel für Chitinpräparate: Diäthylentriamin. – *Mikrokosmos* **69**: 395–397; Stuttgart.
- KUSSAKIN, O. G. (1973): Peculiarities of the geographical and vertical distribution of marine isopods and the problem of deep-sea fauna origin. – *Mar. Biol.* **23**: 19–34; Berlin.
- MAERCKS, H. H. (1930): Sexualbiologische Studien an *Asellus aquaticus* L. – *Zool. Jb. (Abt. Physiol.)* **48**: 399–508; Jena.
- MAGNIEZ, G. J. (1996): *Asellus aquaticus* et ses proches parents: Un étranger parmi la faune asellidienne d'Europe. – *Mém. Biospéol.* **23**: 181–187; Saint Giron.
- SCHMALFUSS, H. (1989): Phylogenetics in Oniscidea. – *Monitore zool. ital. (N.S.) (Monogr.)* **4**: 3–27; Florence.
- SCHRAM, F. R. (1974): Paleozoic Peracarida of North America. – *Fieldiana Geol.* **33**: 95–124; Chicago.
- SEROV, P. A. & WILSON, G. D. F. (1995): A review of the Stenetriidae (Crustacea: Isopoda: Asellota). – *Rec. Aust. Mus.* **47**: 39–82; Sydney.
- SIEG, J. (1983): Evolution of Tanaidacea. – *In*: SCHRAM, F. R. (ed.): *Crustacean phylogeny*: 229–256; Rotterdam (A. A. Balkema).
- (1984): Neuere Erkenntnisse zum natürlichen System der Tanaidacea. – *Zoologica* **136**: 1–132; Stuttgart.
- TABACARU, I. & DANIELOPOL, D. L. (1999): Contribution à la connaissance de la phylogénie des Isopoda (Crustacea). – *Vie Milieu* **49**: 163–176; Banyuls-sur-Mer.
- VAN LIESHOUT, S. E. N. (1983): Calabozoidea, a new suborder of stygobiont Isopoda, discovered in Venezuela. – *Bijdr. Dierk.* **53**: 165–177; Leiden.
- VEUILLE, M. (1978): Biologie de la reproduction chez *Jaera* (Isopode Asellote). I. Structure et fonctionnement des pièces copulatrices mâles. – *Cah. Biol. Mar.* **29**: 299–308; Paris.
- WÄGELE, J.-W. (1983): On the origin of the Microcerberidae (Crustacea: Isopoda). – *Z. zool. Syst. Evolut.-Forsch.* **21**: 249–262; Hamburg & Berlin.
- (1989): Evolution und phylogenetisches System der Isopoda. Stand der Forschung und neue Erkenntnisse. – *Zoologica* **140**: 1–262; Stuttgart.
- (1994): Review of methodological problems of 'Computer cladistics' exemplified with a case study on isopod phylogeny (Crustacea: Isopoda). – *Z. zool. Syst. Evolut.-Forsch.* **32**: 81–107; Hamburg & Berlin.
- WILSON, G. D. F. (1987): The road to the Janiroidea: Comparative morphology and evolution of the asellote isopod crustaceans. – *Z. zool. Syst. Evolut.-Forsch.* **25**: 257–280; Hamburg & Berlin.
- (1991): Functional morphology and evolution of isopod genitalia. – *In*: BAUER, R. T. & MARTIN, J. W. (eds.): *Crustacean sexual biology*: 228–245; New York (Columbia Univ. Press).
- WILSON, G. D. F. & HO, E. L. (1996): *Crenoicus* Nicholls, 1944 (Crustacea, Isopoda, Phreatoicoidea): Systematics and biology of a new species from New South Wales. – *Rec. Aust. Mus.* **48**: 7–32; Sydney.
- WILSON, G. D. F. & KEABLE, S. J. (In press): Systematics of the Phreatoicoidea. – Submitted, Crustacean Issues Series; Rotterdam (A. A. Balkema).
- WILSON, G. D. F. & PONDER, W. F. (1992): Extraordinary new subterranean isopods (Peracarida: Crustacea) from the Kimberley Region, Western Australia. – *Rec. Aust. Mus.* **44**: 279–298; Sydney.

Author's address:

Dr. FRIEDHELM ERHARD, Staatliches Museum für Naturkunde (Museum am Löwentor),
Rosenstein 1, D-70191 Stuttgart;
e-mail: h.f.erhard@t-online.de.

ISSN 0341-0145

Schriftleitung: Dr. Wolfgang Seeger, Rosenstein 1, D-70191 Stuttgart
Gesamtherstellung: Gulde-Druck GmbH, D-72072 Tübingen

ZOBODAT - www.zobodat.at

Zoologisch-Botanische Datenbank/Zoological-Botanical Database

Digitale Literatur/Digital Literature

Zeitschrift/Journal: [Stuttgarter Beiträge Naturkunde Serie A \[Biologie\]](#)

Jahr/Year: 2001

Band/Volume: [624_A](#)

Autor(en)/Author(s): Erhard Friedhelm

Artikel/Article: [Morphological and Phylogenetical Studies in the Isopoda \(Crustacea\). Part 4: The Pleopods and Uropods in the Asellota 1-51](#)