

# Sedimentology and facies zonation along a transect through the Gulf of Trieste, Northern Adriatic Sea

## Sedimentologie und Fazieszonierung entlang eines Transektes durch den Golf von Triest, Nördliche Adria

by

Martin ZUSCHIN and Werner E. PILLER

ZUSCHIN, M. & PILLER, W.E., 1994. Sedimentology and facies zonation along a transect through the Gulf of Trieste, Northern Adriatic Sea. — Beitr. Paläont., 18:75-114, 19 Figures, 7 Tables, 1 Appendix, Wien.

### Contents

Abstract	75
Zusammenfassung	76
1. Introduction .....	76
2. General setting	77
3. Methods	79
4. Transect description	80
4.1. Morphology and bottom types .....	80
4.2. Macroepibenthic facies .....	80
5. Sedimentology	81
5.1. Grain size distribution	81
5.2. Grain size parameters	83
5.3. Carbonate content .....	85
5.4. Statistical analysis	85
5.5. Sedimentary facies	85
5.6. Interpretation .....	86
6. Sediment composition .....	86
6.1. Component categories	86
6.2. Component distribution .....	88
6.3. Statistical analyses .....	90
6.4. Component facies .....	100
6.5. Interpretation .....	100
7. Facies .....	101
8. Conclusions .....	103
9. Acknowledgements .....	104
10. References .....	104

### Abstract

A 9 km long transect in the Gulf of Trieste, extending from the coastal cliff in the E across the Bay of Panzano into the Isonzo delta in the W, was investigated and sampled by scuba-diving.

Four sediment facies types were distinguished visually: sublittoral sand, sublittoral mud, delta foreset beds, and delta top depositions.

The sediments were analysed with respect to grain size, carbonate content, as well as qualitative and quantitative composition of the sieve-fractions > 250 µm. Statistical analyses included cluster-, correlation-, and factor-analyses. Grain size analyses reveal a characteristic sediment

distribution pattern along the transect: In a narrow strip along the coastal cliff, gravelly sands are found, sharply bordered by silt-clays and clay-silts, extending several km across the bay. Closer to the Isonzo the sediments become coarser, ranging from sandy clay-silts to clayey-sandy silts which pass into gravelly sands and sands at the delta top.

Carbonate contents show a distribution pattern similar to grain size: High contents occur along the coastal cliff, reaching their lowest values a short distance basinwards. Approaching the Isonzo they increase gradually at first, then rising abruptly to reach the highest values from the delta foreset to the delta top.

On the basis of a component analysis 29 component types were distinguished of which carbonate rock fragments, bivalves and ophiurids were most abundant. The components show a characteristic distribution along the transect. At the coastal cliff, carbonate rock- and quartz-sandstone fragments are very abundant. A short distance from the coast a broad area dominated by bivalves and ophiurids begins and continues across the bay. Approaching the Isonzo, the content of carbonate rock fragments increases strongly, whereas all skeletal particles disappear. At the delta top almost only carbonate fragments are found. The components are classified into 5 groups, of which 4 are facially diagnostic.

Considering all data, 4 integrated facies can be distinguished on the basis of cluster analysis: a terrigenous biogenic facies, a bivalve-ophiurid facies, a terrigenous plant facies, and a terrigenous rock fragment facies.

The distribution of terrigenous sediments is mainly controlled by the Isonzo, coastal cliff erosion being restricted to a narrow strip along the coast. The sediment transport switches from bedload to suspension load with increasing distance from the river mouth. The carbonate content is controlled by the distribution of carbonate rock fragments and therefore also mainly by the input of the Isonzo; coastal cliff erosion is only of

local importance, skeletal production being insignificant. Autochthonous sediment production is represented by skeletal particles only and depends on grain size and substrate stability. The substrate is stable wherever transport of sediment by bedload is negligible. Instability increases with decreasing distance from the Isonzo, creating unsuitable conditions for colonization by sediment-producing benthic organisms. As a consequence, the Isonzo not only controls the distribution of most terrigenous sediments, but indirectly also the autochthonous biogenic sediment production.

## Zusammenfassung

Im Golf von Triest wurde ein 9 km langes Transekt quer über die Bucht von Panzano an 18 Punkten im Scuba-Tauchsatz beprobt. Das Transekt reicht von der Steilküste im E bis zum Isonzo Delta im W. Die Beobachtungen des Meeresbodens während der Probenahme ließen 4 Bodenfaziestypen unterscheiden: sublitoraler Sand, sublitoraler Schlamm, Deltavorsetzschichten, Deltatopablagerungen.

Die Sedimente wurden auf Korngrößenverteilung, Karbonatgehalt und qualitative wie quantitative Zusammensetzung der Korngröße  $> 250 \mu\text{m}$  untersucht, die Daten mit Hilfe von statistischen Methoden (Cluster-, Korrelations-, Faktorenanalyse) ausgewertet.

Die Korngrößenanalysen ergaben sehr unterschiedliche Sedimente, die ein charakteristisches Verteilungsmuster entlang des Transektes zeigen: In einem schmalen Streifen entlang der Steilküste finden sich sehr grobkörnige kiesige Sande, an die mit scharfer Grenze ein mehrere km breites Gebiet mit Silttonen und Tonsilten anschließt. Erst im Einflußbereich des Isonzodeltas finden sich wieder gröbere Sedimente in Form von sandigen Tonsilten und tonig-sandigen Silten, die am Deltatop in kiesige Sande und Sande übergehen. Letztere sind am besten sortiert.

Die Karbonatgehalte sind sehr unterschiedlich und zeigen eine ähnliche Abfolge wie die Korngrößenverteilungen: In einem schmalen Streifen entlang der Steilküste sind sie sehr hoch, fallen in geringer Entfernung von der Küste abrupt auf ihre niedrigsten Werte ab und steigen mit Annäherung zum Isonzo allmählich an. Von den Deltavorsetzschichten zum Deltatop erfolgt ein rapider Anstieg zu den höchsten Werten.

Die Komponentenanalyse führte zur Unterscheidung von 29 Komponenten-kategorien, von denen Karbonatgesteinsfragmente, Bivalven und Ophiuren am wichtigsten sind. Die Komponenten zeigen entlang des Transektes und in den einzelnen Fraktionen ein charakteristisches Verteilungsmuster. In dem schmalen Streifen an der Steilküste sind Karbonatgesteins- und Quarzsandsteinfragmente sehr häufig und in allen Frak-

tionen etwa gleich bedeutend. Schon in geringer Entfernung von der Steilküste beginnt ein mehrere km breites Gebiet, in dem vor allem Bivalven und Ophiuren dominieren. Im Einflußbereich des Deltas nimmt mit zunehmender Annäherung an den Isonzo in den feineren Fraktionen der Gehalt an Karbonatgesteinsfragmenten drastisch zu. Auch der Gehalt an Pflanzenresten steigt an, besonders in der Grobsandfraktion, während alle übrigen Biogene verschwinden. Am Deltatop finden sich fast nur noch Karbonatgesteinsfragmente. Die Komponenten können in 5 Gruppen gegliedert werden von denen 4 faziell aussagekräftig sind.

Unter Berücksichtigung aller Daten können – unterstützt durch eine Clusteranalyse – 4 Faziesbereiche unterschieden werden: Terrigene Biogenfazies, Bivalven-Ophiurenfazies, Terrigene Pflanzenfazies, Terrigene Gesteinsfragmentfazies.

Die Verteilung der terrigenen Sedimente wird hauptsächlich durch den Isonzo gesteuert und in flächenmäßig nur sehr geringem Ausmaß durch die Steilküstenerosion. Während der Eintrag des Isonzo über das ganze Profil verteilt wird, bleiben die Erosionsprodukte der Steilküste auf einen schmalen Küstenstreifen beschränkt. Der Transportmechanismus ändert sich mit zunehmender Entfernung von der Isonzomündung von Bodenfracht zu Suspensionsfracht. Autochthones Sediment wird ausschließlich durch biogene Partikel produziert. Deren Verteilung hängt von der Korngröße sowie der Stabilität des Substrates ab. Stabil ist es dort wo Sedimenttransport durch Bodenfracht gering ist. Die Instabilität steigt mit Annäherung zur Isonzomündung, wodurch die Bedingungen für die Ansiedlung benthischer Organismen ungünstiger werden. Der Isonzo steuert somit nicht nur die Verteilung eines Großteiles der terrigenen Sedimente, sondern indirekt auch die biogene Sedimentproduktion. Die typische Makroepibenthosgemeinschaft des Golfes hat nahezu kein Fossilisationspotential, trotzdem deckt sich ihre Verbreitung mit jener der Bivalven-Ophiurenfazies, womit sie indirekt doch im Sediment dokumentiert wird.

## 1. Introduction

The Gulf of Trieste represents the northernmost part of the Adriatic Sea and is of special interest to both biologists and earth scientists due to its very marginal position in the Mediterranean Sea. This fact is documented in the results of a variety of sedimentological (e.g., BRAMBATI & VENZO, 1967; VENZO & STEFANINI, 1967; STEFANINI, 1968; OGORELEC et al., 1991) and biological studies (e.g., FEDRA et al., 1976; FEDRA, 1977, 1978; ÖLSCHER & FEDRA, 1977; STACHOWITSCH, 1977). In particular, the

occurrence of several anoxic events in the last two decades led to an upsurge of studies in this region (e.g., STACHOWITSCH, 1984, 1986, 1991; FAGANELI et al., 1991; JUSTIC, 1991).

In addition, the Gulf of Trieste, in particular its northernmost part, the Bay of Panzano (Fig. 1a), was and still is subject to several actualistic studies dealing with different biological aspects and its palaeontological implications. These studies cover several aspects on foraminifera, especially their spatial distribution in intertidal and subtidal areas (HOHENEGGER et al., 1989, 1993), as well as on the origin and spatial distribution of lebensspuren (PERVESLER, 1985; PERVESLER & DWORSCHAK, 1985; HOHENEGGER & PERVESLER, 1985). Most of these investigations, as well as those on the population dynamics of foraminifera (ROSCHAL, 1991) and the studies on the distribution of foraminifera and molluscs being currently under study, are carried out along a transect across the Bay of Panzano. The sample positions for all these investigations are more or less identical. Since the distribution patterns of several organism groups are highly related to the sediment, a detailed knowledge of sediment properties and facies along this transect was of particular interest and serves as background to this study.

## 2. General setting

The Gulf of Trieste is separated from the Northern Adriatic Sea by a shoal along a line between Grado (Italy) and the Savudrija-Peninsula (Croatia) (Fig. 1a). It thus forms a shallow marine basin (down to 25 m), its coast being characterized by two completely different geological/geomorphological features: the Istrian carbonate platform forming the Karst and cliffed coast in the east and the Friuli Plain in the west. The cliffed coast is structured by river mouths drowned during the Quaternary transgression, whereas the west coast is dominated by the delta of the river Isonzo.

The hydrography of the Adriatic Sea is characterized by a counterclockwise gyre driven by a thermohaline density gradient along the northern Adriatic shelf (MOSETTI, 1967). This current regime drives warm, oligotrophic and hypersaline water from the Ionian Sea into the northern Adriatic, where it is diluted by strong river input. The main northerly current turns to the west around Savudrija-Peninsula before entering the Gulf of Trieste (Fig. 1b). The general water circulation is dominated by strong tidal currents which can be strongly influenced by wind-driven currents generated by local winds (Bora, Scirocco).

The interpretation of the current regime inside the Gulf of Trieste is controversial (clockwise: BRAMBATI &

VENZO, 1967; counterclockwise: MOSETTI, 1967). It is, however, mainly controlled by river input, tidal range (around 0.5 m) and predominantly northnortheast-erly winds (OGORELEC et al., 1991). The latter are responsible for a frequent and complete mixing of the water column within only a few days!

Average salinities of the Gulf range from 33–38 ‰ at the surface and 36–38.5 ‰ at the bottom. In late spring, lower values are caused by increased river input. Water temperatures range from 8°–24°C at the surface and 8°–20°C at the bottom. During the summer season temperature gradients, reaching 8°–10°C, occur in combination with high density stratification, the latter being often combined with hypoxic events (OGORELEC et al., 1991).

The northern and central Adriatic shelf is covered by modern as well as relict sediments. Pleistocene relict sands cover the main part of the shelf, their thickness ranging from 2–30 cm only (VAN STRAATEN, 1970). Recent sands are restricted to a narrow coastal zone. These are separated from the relict sand by a “prolittoral mud belt” (VAN STRAATEN, 1970), resulting from the deposition of recent terrigenous muds. The maximum accumulation rate of mud amounts to about 4.5 mm a<sup>-1</sup>.

Sedimentation in the Gulf of Trieste is mainly controlled by river input (BRAMBATI & VENZO, 1967), spatial sediment distribution patterns clearly demarcating three major depocenters (Fig. 1c). The northern and southern parts of the Gulf are characterized by the terrigenous input of the rivers Isonzo (in the north) and Rosandra (in the south). This input is reflected by a strong concentric zonation pattern with decreasing grain size in a seaward direction (OGORELEC et al., 1991). The central and southwestern part of the Gulf is dominated by sandy (relict) sediments. Some sediments along the coastal cliff are produced by coastal erosion, predominantly by the activity of endolithic and epilithic organisms (e.g., TORUNSKI, 1979; KLEEMANN, 1973; FÜTTERER, 1974). The carbonate content generally increases seawards, comprising calcitic, aragonitic and dolomitic components (OGORELEC et al., 1991). Aragonite and part of the calcite are of skeletal origin, the remainder being terrigenously supplied. Coarser sediments exhibit higher carbonate values than finer sediments (VENZO & STEFANINI, 1967) and while skeletal remains are present in all sediments, the general carbonate distribution pattern is not modified by these (BRAMBATI & VENZO, 1967). The sediments delivered by the Isonzo have an average carbonate content of 77 % (STEFANINI, 1968). The non-carbonate sediment content is dominated by quartz accompanied by clay minerals, feldspar, and pyrite (OGORELEC et al., 1991).

Sedimentation rates are highest in smaller bays (3–

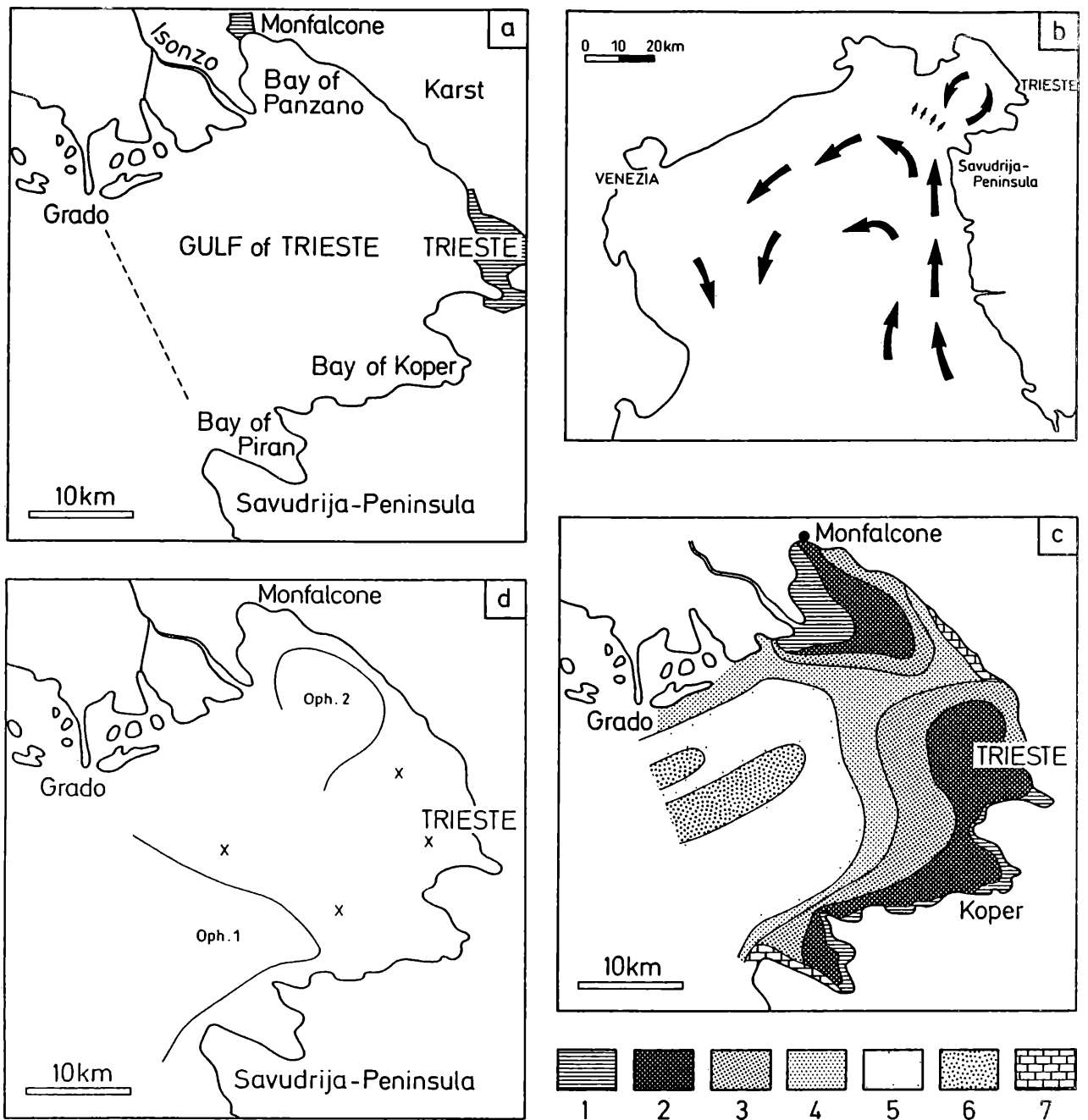

**Fig. 1:** The Gulf of Trieste: (a) General overview. (b) Current pattern of the northern Adriatic sea (after MOSETTI, 1967). (c) Sediment distribution (1 = coastal zone of sandy silt; 2 = central parts of the Bays with clayey silt; 3 = inner transitional zone with silt; 4 = outer transitional zone with sandy silt; 5 = open Gulf with silty sand; 6 = central Gulf with coarse sand of organic fragments; 7 = silty sand of eroded and biogenic fragments along the cliff-coast) (after OGORELEC et al., 1991). (d) Macroepibenthic communities (x = *Ophiura lacertosa* community, Oph. 1 = southern *Ophiothrix* community, Oph. 2 = northern *Ophiothrix* community) (after FEDRA, 1978).

5 mm a<sup>-1</sup>) and decrease to 1 mm a<sup>-1</sup> in the central parts of the Bay. Around the river mouth of the Isonzo approx. 2.5 mm a<sup>-1</sup> have been estimated (OGORELEC et al., 1991). The unconsolidated marine sediments reach a thickness of more than 200 m in the western part of the Gulf. They are underlain mainly by Eocene Flysch deposits, limestones being present only in the northernmost part (MORELLI & MOSETTI, 1968). Three epibenthic communities, differing not only in species composition but also in biomass, can be

distinguished in the Gulf of Trieste (Fig. 1d): a more widespread *Ophiura lacertosa* community of low biomass per unit area (around 100 g m<sup>-2</sup>), consisting mainly of motile detritivores and predators, and two *Ophiothrix* communities. Both of the latter are dominated by suspension feeders having a biomass > 200 g m<sup>-2</sup>. The *Ophiothrix-Reniera-Microcosmus* community prevails in the southeastern part of the Gulf. It has the highest biomass per unit area (up to 370 g m<sup>-2</sup>). By contrast, a large part of the Bay of Panzano

is characterized by an *Ophiothrix* community, in which ascidians are largely missing, as do several sponge species. This results in a lower epifaunal biomass (FEDRA et al., 1976; FEDRA, 1977, 1978).

### 3. Methods

Along the transect across the Bay of Panzano (Fig. 2), 18 samples of superficial sediments were collected by scuba-diving. The sampling device consisted of a plastic box with a quadratic opening (9 x 9 cm). It was pushed 6 cm into the sediment, collecting nearly 500 cm<sup>3</sup>. The sample position was determined by compass bearings of conspicuous land marks. In addition, descriptions of the sampling sites were carried out and water depths, temperatures and salinities were recorded (Table 1). To remove salt, the samples were placed into buckets and gently stirred in tap water. After several days, when

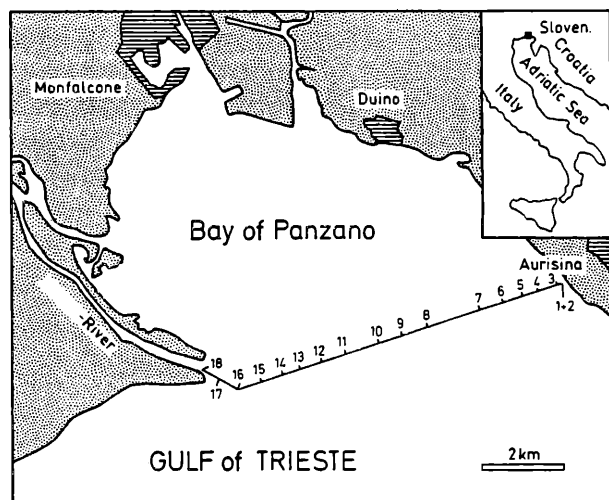

Fig. 2: Location of the transect and sample localities.

the suspended material had settled, the water was sucked off and fresh tap water was added. This procedure was repeated three times. After desalination, the samples were placed in metal jars and oven dried by 60–70°C. For grain size analysis 100 g of dry sediment were separated, placed into tap water and treated ultrasonically for 3 minutes. No detergents were added in order not to

destroy individual sediment particles. Grain size distributions > 32 µm were carried out by wet sieving in half-phi intervals, with the exception of the finest fraction (63–32 µm) which was collected in a one phi-interval. Interval limits were: 2.0–1.4–1.0–0.71–0.5–0.355–0.25–0.18–0.125–0.09–0.063–0.032 mm. Due to the high amount of fine fraction, the sieving procedure had to be performed by hand, the fraction < 0.032 mm being collected in a jar. The sieved material was dried and weighed. The difference between this weight and the original weight (100 g) corresponds to the fraction < 0.032 mm. The grain size distribution of the fine fraction (< 0.032 mm) was analysed by Sedigraph (Micromeritics 5100). All resulting grain size data were processed on a personal computer using the “Basic” program “Sedpack-4” (MALECKI, 1986; revision 1990). The sediments were texturally classified according to their position in either the gravel-sand-silt- or sand-silt-clay triangular diagram.

For the component analysis the seven larger fractions (between 2.0 and 0.25 mm) of the sieve analyses were used. Using a binocular microscope, the particles of each fraction were first separated into several component categories and then counted. From the particle numbers in each category, their percentage contribution to each fraction and to the entire sediment > 0.25 mm was computed. In order to obtain statistically representative numbers, 400 grains were counted in each fraction. This number was not always reached in the three largest fractions due to low sample volumes. When grain numbers exceeded the limit, a microsampler was used for reduction to 500–1000 grains. The carbonate content was determined by CO<sub>2</sub>-gasometry (“Karbonat-Bombe”: MÜLLER & GASTNER, 1971). All data were statistically analysed including cluster analyses (Ward’s method using Euclidian distances as similarity measure), correlation analyses (Pearson’s correlation coefficient), and factor analyses (Principal component analyses). All statistical analyses were computed with the SPSS-program package (SCHUBÖ & UEHLINGER, 1986) on the main frame computer of the Computer Center of the University of Vienna.

		AU1	AU2	AU3	AU4	AU5	AU6	AU7	AU8	AU9	AU10	AU11	AU12	AU13	AU14	AU15	AU16	AU17	AU18
temperature	surface	/	/	/	22.2	22.1	/	22.2	/	25.5	24.8	25.2	25.4	25.3	24.7	24.7	24.8	22.9	21.3
	bottom	23.1	23.2	22.4	20.4	20.9	/	/	/	21.3	21.4	21.2	21.6	21.9	22.5	22.6	23.1	/	25.7
pH	surface	/	/	/	/	/	/	/	/	7.15	7.14	7.11	7.09	7.15	7.13	7.16	7.20	7.20	7.20
	bottom	/	/	/	/	/	/	/	/	7.07	7.04	7.03	6.95	6.95	7.02	6.95	6.99	/	/
salinity	surface	/	/	/	42	39	/	40	32	32	38	38	36	39	37	25	12	4	7
	bottom	39	39	39	/	40	/	/	39	39	39	39	38	39	39	39	37	/	26

Table 1: Temperature, salinity, and pH-values at the sample points (July 1990).

## 4. Transect description

The transect is about 9 km long and includes 18 sample stations (Fig. 2). It is located between the Laboratorio di Biologia Marina – Sorgenti di Aurisina and the Punta Sdobba (lighthouse off the Isonzo mouth), running ENE–WSW. At the Punta Sdobba the direction changes to WNW, from where the transect continues for about 1 km into the Isonzo delta. Water temperatures, salinities and pH-values recorded at the time of sampling (July 1990) are documented in Table 1.

### 4.1. Morphology and bottom types

The steep wall of the Karst is situated about 30 m from the water line. The littoral zone is protected by a steep man-made boulder revetment, reaching down to a water depth of about 5 m. Immediately seawards, a **zone of sublittoral sand** commences, sloping to the SW and rapidly grading into sublittoral mud. The first two sample points (AU1, AU2) are located in these sublittoral sands, adjacent to the coast in water depths of 6–7 m (Fig. 3).

**Sublittoral mud** occurs along most of the transect which gradually descends towards the center of the basin, where the greatest depth of 14 m is reached. Towards the Isonzo, the sea bed gradually ascends. The sample points AU3–AU12 are located in this area of sublittoral mud, extending for 5.5 km along the transect in water depths between 11 and 14 m (Fig. 3).

A zone of **delta foreset beds** follows in a WSW direction, being characterized by a distinct shoaling and an increase in silt content. The sample points AU13–AU16 are located in this 2.5 km section of the transect, where the sea bed rises from 11 to 3 m (Punta Sdobba), at water depths of 8–3 m (Fig. 3).

The final kilometer of the transect crosses a very shallow area of predominantly well rounded gravels to sands, attributed to **delta top deposits**. Samples AU17 and AU18 were recovered at water depths < 1 m of this section (Fig. 3).

### 4.2. Macroepibenthic facies

In addition to the bottom facies types the transect can further be subdivided using macroepibenthic communities and the distribution of seagrass (Fig. 4).

**Macroepibenthic Facies 1:** The boulder zone is colonized by patellids, ostreids and mytilids in the eulittoral zone. In its sublittoral part an association of hard bottom dwellers is developed, including sponges (*Verongia aerophobia*, *Hemimycale columella*, *Tethya aurantium*), echinoids (*Paracentrotus lividus*), asteroids (*Marthasterias glacialis*), and ascidians (*Phallusia mammilata*, *Microcosmus sulcatus*). Among macroalgae, *Padina pavonia* is abundant.

This facies is not represented by a sediment sample.

**Macroepibenthic Facies 2:** A seagrass meadow of *Cymodocea nodosa* covers the sublittoral sand in front of the boulder ramp in 5–7 m water depth. This seagrass meadow acts as a sediment trap and shelters a diverse fauna. Most obvious are: *Pinna nobilis*, *Murex brandaris*, *Trunculariopsis trunculus*, *Protopecten glaber*, *Chlamys varia*, *Spirographis spallanzani*, *Protula tubularia*, *Parthenope angulifrons*, *Iliia nucleus*, *Paguristes oculatus* with *Calliactis parasitica*, and *Holothuria tubulosa*. In areas with sparse seagrass stock the burrow openings of *Upogebia pusilla* are abundant (PERVESLER, 1985).

Sample point AU1 is located in this facies.

**Macroepibenthic Facies 3:** The seagrass of Facies 2

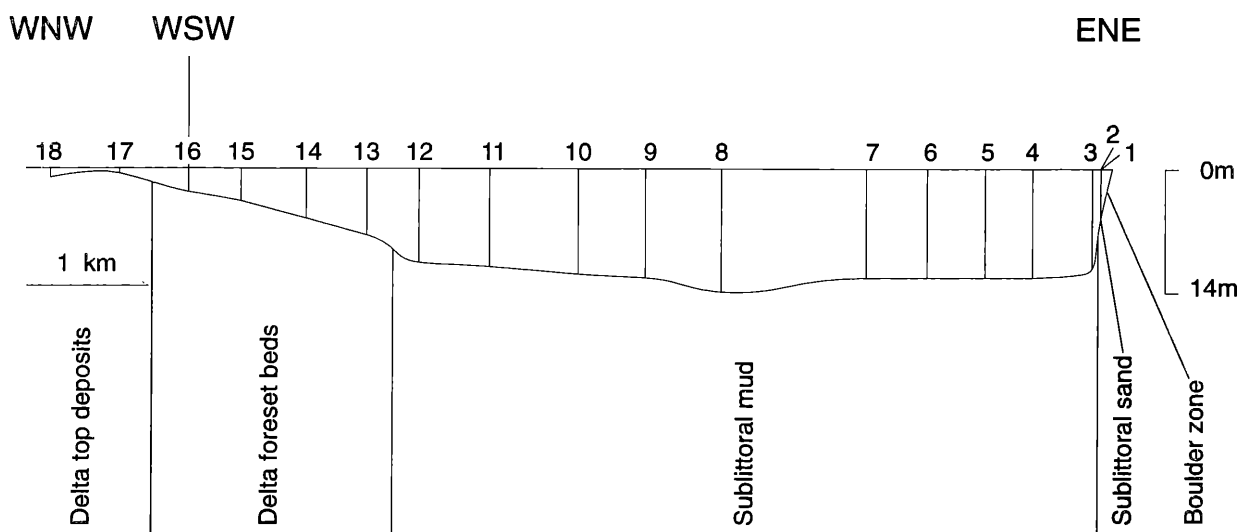

Fig. 3: Morphology and bottom types along the transect.

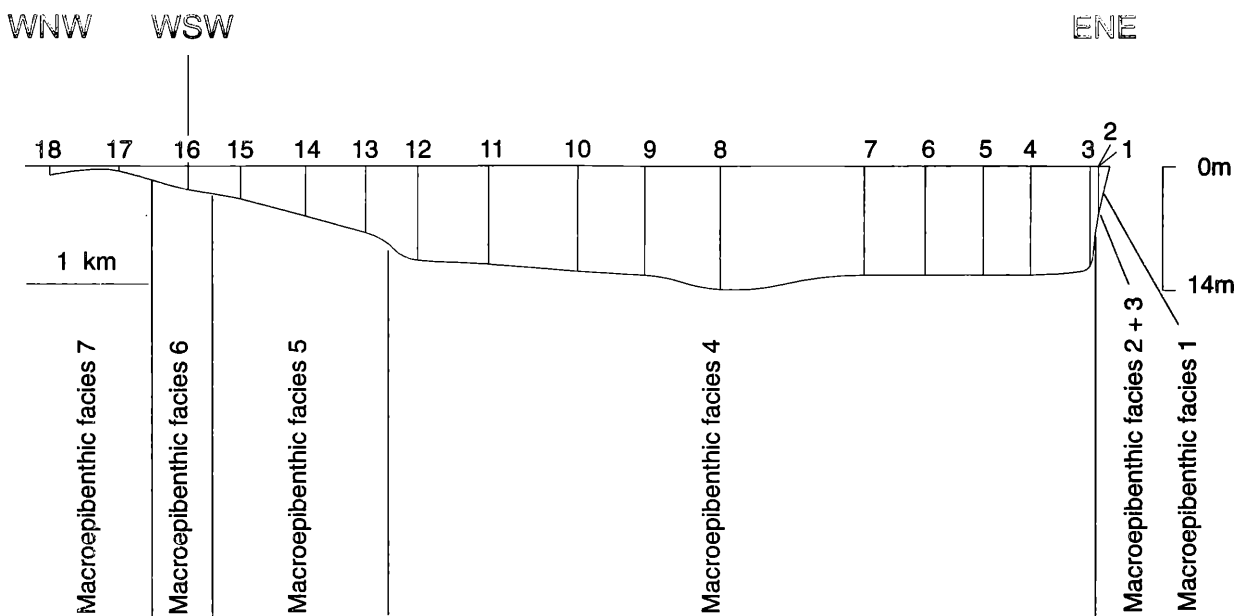

Fig. 4: Distribution of macroepibenthic facies along the transect

disappears at 7 m water depth and the sandy sediment surface is covered by large patches of the macroalgae *Ulva rigida*. The epibenthic fauna is similar to Facies 2, the burrows of *Upogebia pusilla* increase in abundance up to 200 pairs of openings per m<sup>2</sup> (PERVESLER, 1985).

Sample AU2 originates from this facies.

**Macroepibenthic Facies 4:** The spatial coverage of this facies is identical to that of the sublittoral mud. Its very soft substrate is occupied by a variety of ophiurids (*Ophiura albida*, *Ophiothrix quinquemaculata*, *Ophiura lacertosa*, *Ophiothrix fragilis*), gastropods (e.g., *Aporrhais pespelicani*, *Philine quadripartita*), holothurians, asteroids, scaphopods, and bivalves (pectinids and small pinnids). The tubes of the polychaete worm *Chaetopterus variopedatus* conspicuously rise over the sediment surface and act as a secondary hard substrate for further settlement. In general, secondary hard substrates are very typical of this facies. Especially mollusc shells dominate, providing substrates for sponges, ascidians, bryozoans, hydrozoans, and algae. These organisms, in turn, provide the substrate for holothurians, ophiurids and crinoids. Together they form ecologically highly complex, multi-species aggregates as described by FEDRA (1977) and STACHOWITSCH (1977). The infaunal association is characterized by burrowing crustaceans, such as *Squilla mantis*, *Jaxea nocturna* and *Upogebia tipica* (PERVESLER, 1985).

Approximately 100–150 m off the cliff-coast floating, man-made mussel culture rafts parallel the coast, supposedly producing large quantities of organic material. Although quantitative data are not available, benthic organism density seems to be increased in the

surroundings of these cultures (compare also ROSCHAL, 1991).

Samples AU3–AU12 come from this facies.

**Macroepibenthic Facies 5:** This facies is located in the area of the delta foreset beds and the epifauna is very similar to Facies 4. The most important difference is a distinct decrease in density. The density of the crustacean burrows also decreases with decreasing distance from the Isonzo.

Sample points AU13–AU15 are located in this facies.

**Macroepibenthic Facies 6:** This facies covers the area around the lighthouse at Punta Sdobba and is still located in the delta foreset beds. It is characterized by a very low diversity of the macroepibenthic fauna which is dominated by pagurids. Patches of seagrass and burrow openings of *Upogebia pusilla* were observed at the time of sampling.

Sample point AU16 is located in this facies.

**Macroepibenthic Facies 7:** This facies corresponds to the delta top beds, is dominated by physical surface structures (wave and current ripples) and is free of macrofaunal or -floral settlement.

Samples AU17 and AU18 originate from this facies.

## 5. Sedimentology

### 5.1. Grain size distribution

Wet sieving and Sedigraph analyses produced cumulative curves which were sorted into 4 groups (Fig. 5). Group I: Gravelly sand with gravel and very coarse sand > 20 % and a mud content < 10 % (Table 2). These samples (AU1, AU2) represent the “sublittoral sands” Group II: Gravelly sand and sand with high percentages

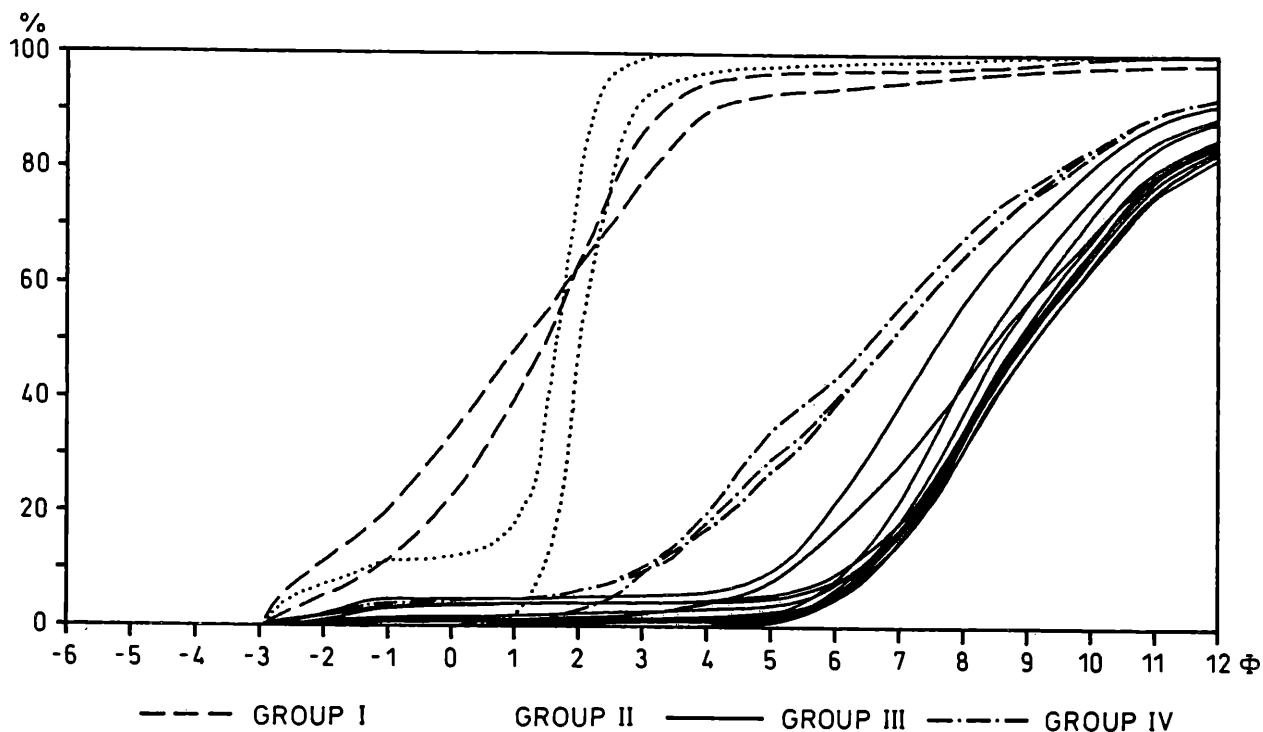

Fig. 5: Cumulative curves of all 18 sediment samples, assembled into 4 groups.

	μm	phi	AU1	AU2	AU3	AU4	AU5	AU6	AU7	AU8	AU9	AU10	AU11	AU12	AU13	AU14	AU15	AU16	AU17	AU18
gravel	>2000	-1	11.59	20.54	0.87	3.46	1.58	0.1	1.02	3.41	0.02	0.8	0.45	0.39	4.60	3.99	0.06	2.91	11.26	0.20
very coarse sand	1400		4.54	6.05	0.21	0.04	0.09	0.03	0.08	0.09	0.01	0.09	0.04	0.03	0.12	0.22	0.05	0.2	0.26	0.06
coarse sand	710	0	6.23	7.05	0.16	0.08	0.09	0.03	0.07	0.07	0.01	0.06	0.03	0.03	0.11	0.21	0.08	0.15	0.47	0.08
medium sand	355	1	7.83	7.37	0.09	0.05	0.08	0.04	0.06	0.07	0.01	0.04	0.03	0.05	0.08	0.22	0.10	0.04	1.43	0.22
fine sand	250	2	9.54	8.16	0.15	0.06	0.09	0.02	0.09	0.08	0.03	0.07	0.08	0.07	0.1	0.27	0.15	0.08	4.13	1.15
very fine sand	180	3	10.52	6.18	0.14	0.05	0.08	0.04	0.09	0.07	0.03	0.08	0.14	0.08	0.11	0.39	0.41	0.40	19.60	9.21
coarse silt	125	4	13.17	8.54	0.10	0.06	0.11	0.06	0.08	0.10	0.04	0.10	0.17	0.08	0.09	1.05	1.77	1.10	41.04	38.49
medium silt	90	5	12.61	6.72	0.10	0.06	0.08	0.06	0.07	0.07	0.05	0.08	0.08	0.05	0.08	1.28	2.24	1.77	18.42	27.34
fine silt	63	6	11.33	7.88	0.35	0.07	0.12	0.08	0.11	0.10	0.06	0.08	0.09	0.06	0.13	1.71	4.27	3.51	2.79	15.91
very fine silt	32	7	4.85	6.84	0.39	0.07	0.14	0.06	0.08	0.07	0.04	0.07	0.05	0.04	0.11	3.24	3.91	1.37	0.16	3.00
coarse clay	22.10	8	2.89	5.22	1.55	0.15	0.19	0.12	0.15	0.10	0.07	0.09	0.07	0.07	0.25	5.49	3.16	6.00	0.03	1.44
medium clay	15.63	9	1.55	3.09	3.81	1.14	1.06	0.9	0.75	0.66	0.60	0.60	0.68	1.12	3.16	11.52	11.10	15.18	0.02	0.97
fine clay	11.05	10	3.35	0.2	3.8	1.4	1.1	1.4	0.9	1.1	1.2	1.4	1.1	2.1	4.6	4.3	4.3	4	0.39	0.2
very fine clay	7.81	11	0	0.4	5.6	2.5	2.5	2.4	2.7	2.2	2.7	2.7	3.3	4.1	7.2	6	7.1	6.3	0	0.3
clay	5.52		0	0.4	5.1	3.5	3.7	3.7	3.8	3.7	3.9	4	4.6	5.6	8.3	6	6.8	6.4	0	0.2
	3.90		0	0.4	5.9	5.1	5	5.3	4.8	5.3	5.8	5.8	6.6	7.7	8.4	6	6.2	6.1	0	0.1
	2.76		0	0.5	6.5	6.9	7.1	7.1	6.9	7	8.1	7.9	8.7	9.8	9	6.5	6.7	6	0	0.2
	2.00		0	0.6	8.2	9.1	9.1	9.3	9.4	9.3	9.7	10.3	10.7	11.2	8.8	6.3	6.3	6	0	0.1
	1.40		0	0.5	7.5	9.4	9.8	9.4	9.8	9.5	10.2	10.2	10.7	10.5	7.8	5.7	5.7	5.2	0	0.2
	1.00		0	0.4	6.2	7.8	8	7.9	7.8	8	8.4	8.2	8.6	8.1	6	4.5	4.5	4.1	0	0.1
	0.70		0	0.4	6	7.5	7.6	7.8	8	7.8	7.9	8.1	8.3	7.4	5.6	4.1	4.3	3.8	0	0.1
	0.50		0	0.3	6.6	6.6	6.6	6.6	6.7	6.7	7	6.6	6.9	6.2	4.9	4	4	3.5	0	0.05
	<0.50		0	0.3	5.5	6.3	6.6	6.7	6.8	6.7	6.8	6.8	6.3	5.8	4.6	3.7	3.6	3.2	0	0.05
			0	0.4	5.7	6.4	6.4	6.4	6.3	6.4	6.3	6.2	6	4.6	3.9	3.3	3.3	3	0	0.1
CaCO <sub>3</sub> %			62	57	26	26	26	26	26	29	31	31	34.5	36.5	42	42	43.5	37	72	79

Table 2: Grain size fractions and carbonate content of all samples.

of medium and fine sand and a mud content < 3 % (Table 3). The samples of the delta top sediments (AU17, AU18) belong into this group.

Group III: Clay-silt and silt-clay with a gravel/sand content of mostly < 2 %, in one case > 5 % (Table 2). This group contains all samples from the "sublittoral muds" (AU3–AU12), as well as AU13 of the delta foreset beds. Samples AU3–AU10 contain the finest

sediments, whereas samples AU11–AU13 have a transitional character towards group IV, due to a higher amount of coarse silt and very coarse silt (Table 2).

Group IV: Sandy clay-silt and clayey-sandy silt with a gravel/sand content up to 18 %. This group comprises samples AU14–AU16 of the delta foreset beds and is characterized by a high content of fine sand to coarse silt (Table 2).



By contrast, a cluster analysis (Ward's method; SCHUBÖ & UEHLINGER, 1986), using the same wet sieve and Sedigraph data, also led to the distinction of four clusters but with a somewhat different sample grouping (Fig. 6a):

Cluster 1 includes the fine grained samples AU3–AU10 of the sublittoral mud, i.e. silt-clay – clay-silt with a high content of medium silt-clay. Cluster 2 comprises the sublittoral mud of AU11 and AU12, as well as sample AU13 of the delta foreset beds, all three comprising clay-silt with a high content of medium to very fine silt. Compared with the samples of Cluster 1, the clay content is lower and coarse – very coarse silts are more abundant. In addition, samples AU14–AU16 (sandy clay-silt – clayey sandy silt) of the delta foreset

beds also belong to this cluster. Cluster 3 unites the two sublittoral sand samples (AU1, AU2), whereas cluster 4 contains the two samples (AU17, AU18) from the delta top.

## 5.2. Grain size parameters

Grain size parameters were calculated not only by graphical methods after FOLK & WARD (1957) but also by moment methods after FRIEDMAN (1962). The results, however, differ widely (Table 3). The arithmetic mean and the 1st moment coincide well, the standard deviation reveals generally lower values than the 2nd moment deviation. In addition, the graphic method and its sorting classes allow a better sample grouping than the moment deviation. Comparing graphic

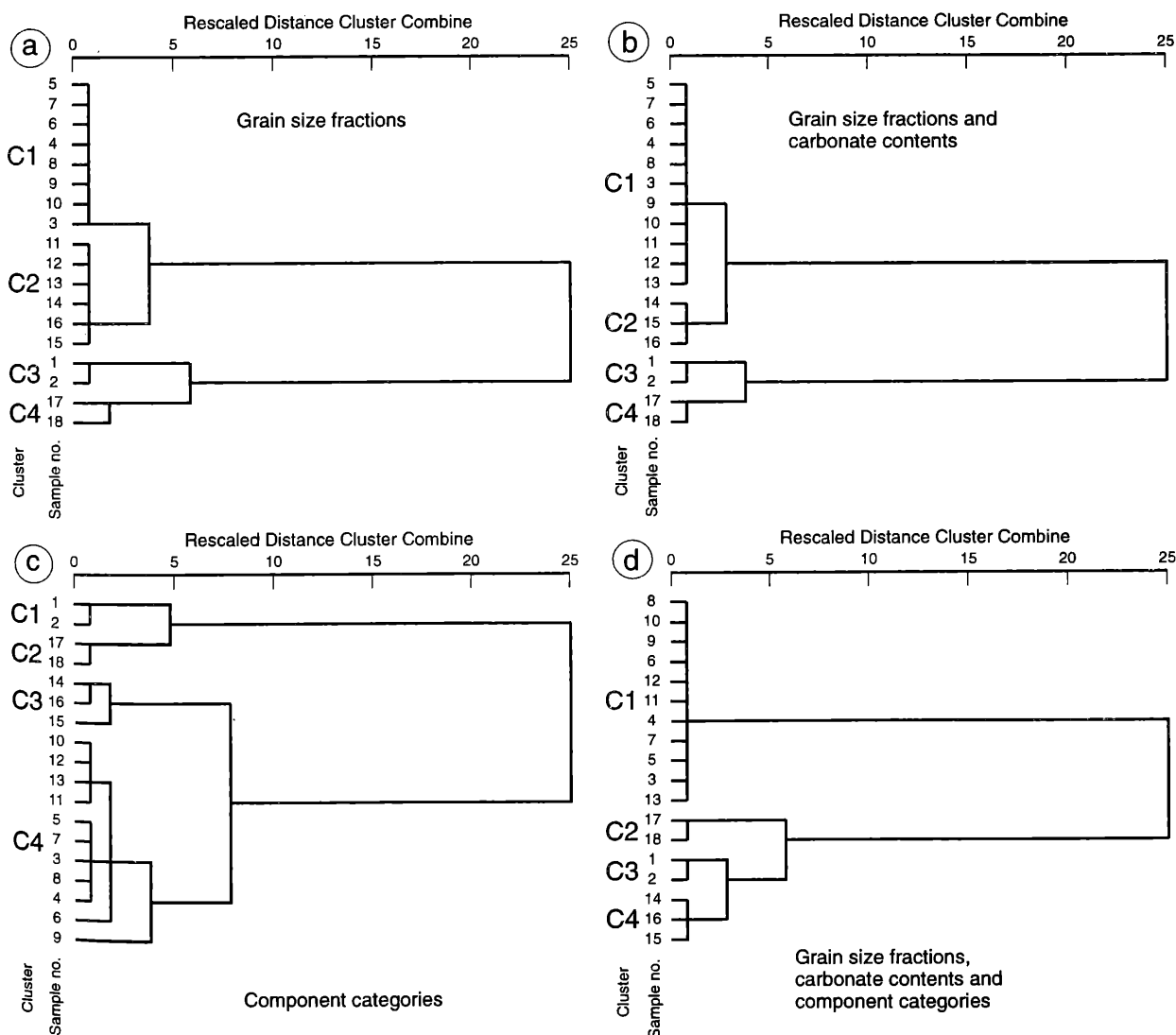

**Fig. 6:** (a) Dendrogram of a cluster analysis (Ward's method) using grain size data. (b) Dendrogram of a cluster analysis (Ward's method) using grain size data and carbonate content. (c) Dendrogram of a cluster analysis (Ward's method) using 29 component categories of seven size fractions. (d) Dendrogram of a cluster analysis (Ward's method) using all grain size fractions, carbonate contents and 29 component categories of fractions > 250  $\mu\text{m}$ .

skewness and the moment skewness reveals enormous differences. The values of the moment skewness could not be meaningfully interpreted, whereas the graphic results coincided well with the particular frequency distributions. Both the data of graphic kurtosis and the moment kurtosis did not produce interpretable results. In general, the moment method reacts more sensitively to the presence of autochthonous gravel content in generally fine-grained sediments. As a result, sublittoral muds and delta foreset beds with high contents of autochthonous, gravel sized shell material show distinct differences between the graphic sorting and skewness values and the corresponding moment statistical values. Low contents of autochthonous gravel produce similar results with both methods. The more stable graphical parameters are therefore given preference in this study.

### 5.2.1. Mean grain size (Fig. 7a, Table 3)

The distribution of mean grain size along the transect correlates well with seabed topography, visually observed sediment types and the grouping of cumulative curves.

Coarsest sediments ( $1-2\phi$ ) occur in the shallow water areas of the sublittoral sand and the delta top sediments. With increasing distance from the delta and the cliff-coast, grain size decreases to  $9.5\phi$  towards the center of the bay.

On the basis of the mean diameters, five sediment groups can be distinguished:

- 1) The coarsest sediments of sublittoral sand (AU1, AU2).
- 2) The finest sediments of sublittoral mud (AU3–AU10).
- 3) The samples AU11–AU13 with slightly increasing mean grain size towards the delta.
- 4) The samples of the delta foreset beds (AU14–AU16) with consistently higher mean grain size.
- 5) The coarse-grained sediments of the delta top (AU17–AU18), which are, however, finer than those of the sublittoral sand.

### 5.2.2. Sorting (Fig. 7b, Table 3)

Sorting alone does not differentiate the samples very sharply: The sublittoral sand is poorly (AU1) or very poorly (AU2) sorted, all samples of sublittoral mud and delta foreset beds being very poorly sorted. The sediments of the delta top are poorly (AU17) and moderately well (AU18) sorted.

Better grouping results are achieved when examining the sorting coefficients in greater detail: they generally decrease from sample AU3 to sample AU12, reflecting that sorting is getting slightly better in that direction. Samples AU13–AU16 show distinctly higher sorting

coefficients, indicating that sorting is getting worse. This pattern clearly reflects the differentiation between sublittoral mud and delta foreset beds, although both range in the same overall sorting class.

The sublittoral sand of sample AU2 cannot be distinguished from sublittoral mud on the basis of sorting coefficients. The best sorted sediments occur at the delta top.

### 5.2.3. Skewness (Fig. 7c, Table 3)

The grain size distributions of the sublittoral sand are negatively skewed (AU1) or symmetrical (AU2). Those of the sublittoral mud and the delta foreset beds (AU3–AU16) are negatively skewed, with the exception of two symmetrical ones (AU13, AU14). One sample of the delta top is very negatively (AU17), the other positively (AU18) skewed. On the basis of skewness, the sublittoral sand sample AU2 and the delta top sample AU18 cannot to be distinguished from sublittoral mud and delta foreset beds.

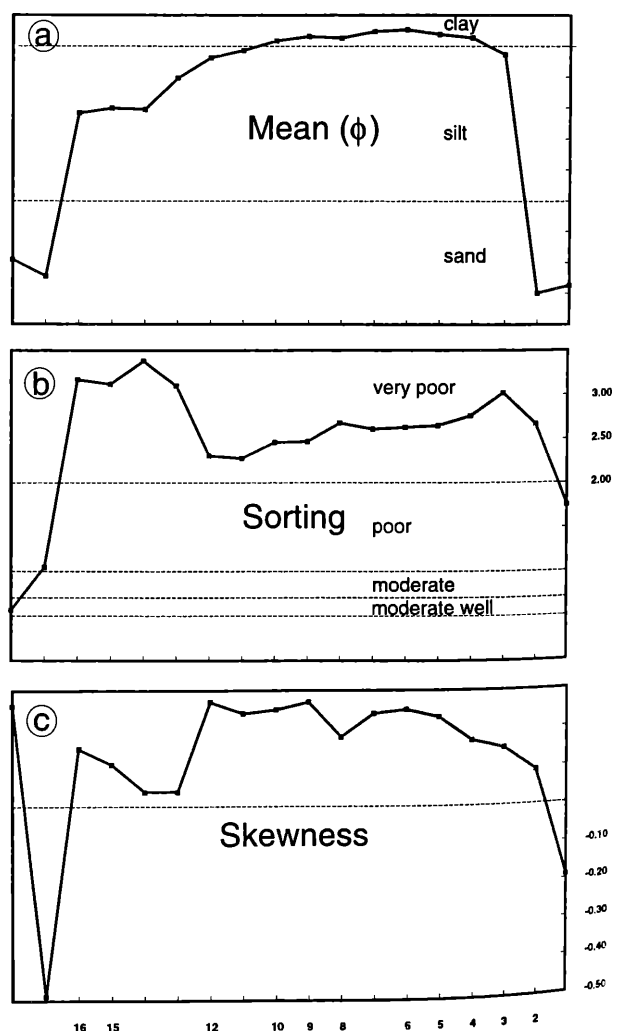

Fig. 7: Distribution of arithmetic mean (a), sorting (b), and skewness (c) along the transect.

	Mean		Sorting		Skewness		Kurtosis	
	F & W	1. mom	F & W	2. mom	F & W	3. mom	F & W	4. mom
AU 1	1.26	1.46	1.75	2.03	-0.19	0.60	1.09	4.87
AU 2	1.01	1.51	2.67	2.92	0.09	1.38	1.16	6.58
AU 3	8.72	8.79	3.02	3.13	0.15	-0.19	1.07	3.27
AU 4	9.27	9.13	2.76	3.32	0.17	-1.02	1.21	5.41
AU 5	9.38	9.33	2.65	2.99	0.23	-0.66	1.15	4.93
AU 6	9.53	9.60	2.63	2.63	0.25	0.14	1.10	2.58
AU 7	9.47	9.45	2.61	2.85	0.24	-0.46	1.13	4.52
AU 8	9.26	9.13	2.68	3.28	0.18	-1.05	1.21	5.60
AU 9	9.31	9.43	2.47	2.50	0.27	0.38	1.13	2.43
AU 10	9.17	9.24	2.46	2.71	0.25	-0.27	1.16	4.51
AU 11	8.86	9.04	2.28	2.53	0.24	0.03	1.17	4.20
AU 12	8.62	8.80	2.31	2.51	0.27	0.23	1.19	3.97
AU 13	7.96	7.85	3.10	3.32	0.04	-0.73	1.57	4.87
AU 14	6.94	6.91	3.38	3.54	0.04	-0.16	1.10	3.27
AU 15	6.98	7.11	3.12	3.13	0.11	0.41	1.02	2.68
AU 16	6.82	6.78	3.17	3.41	0.15	0.08	1.04	3.25
AU 17	1.55	1.41	1.05	1.51	-0.49	1.28	3.31	25.00
AU 18	2.09	2.20	0.57	1.09	0.26	4.79	1.26	41.35

Table 3: Grain size parameters of all samples (F&W = FOLK & WARD, 1957).

5.2.4. Kurtosis (Table 3)

The kurtosis values show no consistent results, except that by using the moment kurtosis the delta top samples are clearly separated from the other.

5.3. Carbonate content

The carbonate content of all 18 samples ranges widely between 26 % and 79 % (Table 2). Its distribution along the transect (Fig. 8) clearly exhibits three sample groups: 1) Sublittoral sand with a high carbonate content (AU1: 62 %, AU2: 57 %).

2) Sublittoral mud and delta forset beds (AU3–AU16) with relatively low values, ranging between 26 % and 43.5 %. This group can be further subdivided: a) AU3–AU7 with a content of 26 % each, and b) AU8–AU16 with contents of 29– 43.5 %, showing a general increase towards the Isonzo.

3) Delta top sediments with highest carbonate contents (AU17: 72 %, AU18: 79 %).

5.4. Statistical analysis

Applying a cluster analysis (Ward’s method) to grain size data and carbonate content, again four clusters are

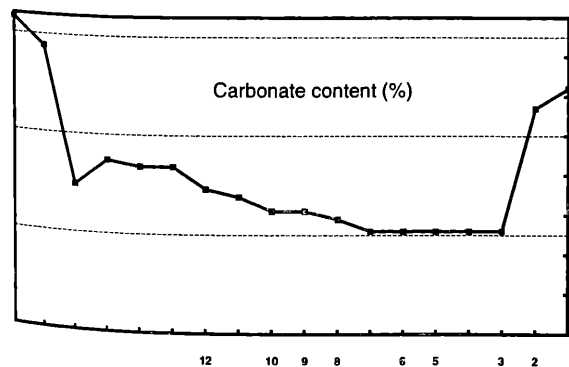

Fig. 8: Carbonate content of 18 samples along the transect.

distinctly separated (Fig. 6b). A clear difference to the cluster analysis calculated on grain size data alone (Fig. 6a), however, is obvious.

Cluster 1 includes all samples of sublittoral mud (AU3–AU12) and sample AU13 of the delta foreset beds, whereas Cluster 2 comprises only samples AU14–AU16 of the delta foreset beds. Cluster 3 and 4 coincide with the cluster analysis based on grain size data alone. Cluster 3 covers the two samples of sublittoral sand (AU1, AU2) and Cluster 4 the two samples of the delta top (AU17, AU18).

Plotting carbonate content against mean grain size reveals that the coarse-grained sediments of the delta top and of the sublittoral sand have distinctly higher carbonate contents than the fine-grained samples of the sublittoral mud and the delta foreset beds (Fig. 9).

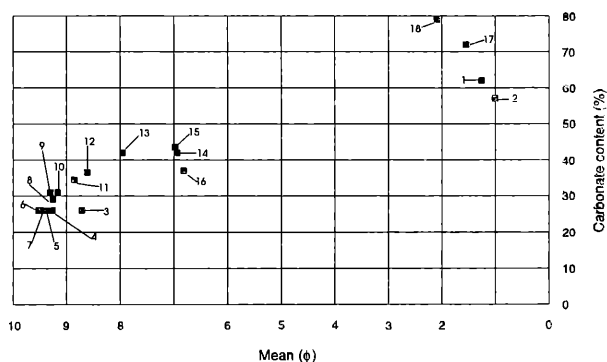

Fig. 9: Relationship between carbonate content and mean grain size.

5.5. Sedimentary facies

Five sedimentary facies can be distinguished on the basis of the cumulative curve grouping, statistical parameters (mean grain size, sorting) and carbonate content. This differentiation is also supported by cluster analyses. The 5 facies are represented by two coarse-grained and three fine-grained sample groups (Fig. 10). The two coarse-grained facies are represented by the **sublittoral sand** (AU1, AU2) at the cliff-coast and by the **delta top sediments** (AU17, AU18) of the Isonzo. Their distinction is not only geographical, but is equally clear on the basis of their cumulative curves, grain size parameters and carbonate contents. The sublittoral sand is characterized by a higher mean grain size due to a high content of coarse sand – fine gravel, whereas the delta top sediments are better sorted and have a higher carbonate content. Both are also separated by cluster analysis.

Among the fine-grained samples, AU14–AU16 show the highest mean grain size values, worst sorting and highest carbonate contents, being clearly separated from samples AU3–AU10 which have lowest mean grain size, best sorting and lowest carbonate content. Samples AU11–AU13 exhibit a transitional character

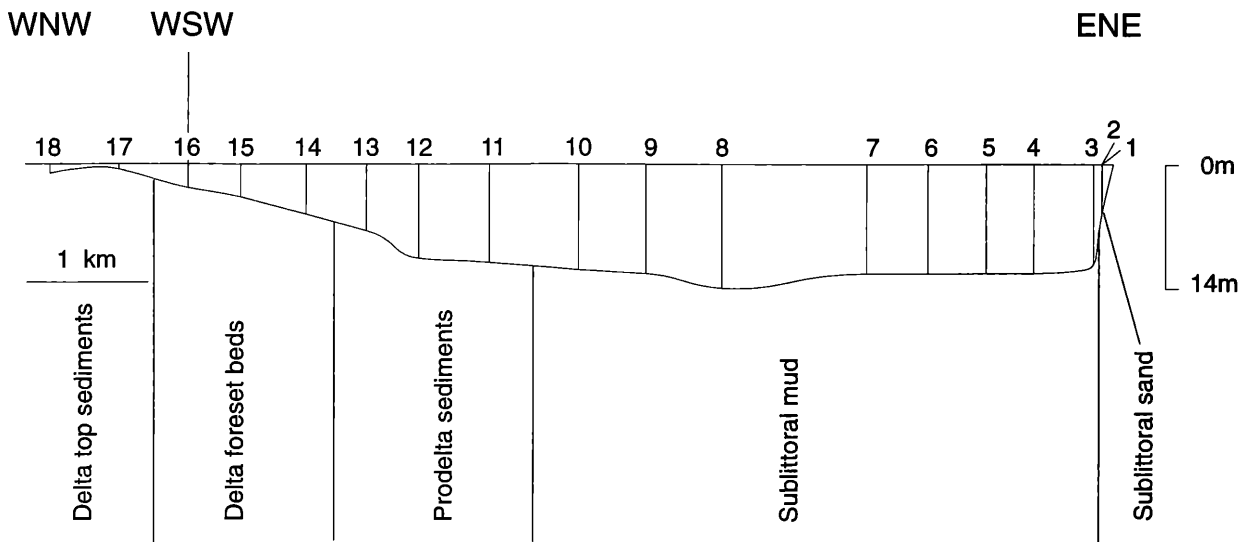

Fig. 10: Distribution of sedimentary facies along the transect.

in having high contents of medium to very fine silt (as AU3–AU10) and increasing amounts of very coarse and coarse silt (as AU14–AU16). The grain size parameters and carbonate contents are also transitional. Using grain size data alone, the cluster analysis groups these samples with samples AU14–AU16, whereas if carbonate content is included, they are clustered with samples AU3–AU10.

Despite the transitional character, it would appear more appropriate to differentiate the fine-grained samples into three sedimentary facies: **sublittoral mud** (AU3–AU10), **prodelta sediments** (AU11–AU13), and **delta foreset beds** (AU14–AU16).

## 5.6. Interpretation

1. The sublittoral sand facies is interpreted as being more or less independent of all other facies. Its sediments mostly originate from the erosion of the cliff-coast, transport into adjacent facies being absent. Proof of this is the characteristic grain size distribution and the high carbonate content which rapidly decreases basinwards. Transport along the coast can also be excluded due to the poor sorting of the sediments.

2. All other sedimentary facies are determined by the fluvial sediment input of the river Isonzo. At the delta top mainly coarse-grained, relatively well sorted sediments are deposited from bedload. The delta foreset beds and the prodelta sediments represent deposition from bedload, decreasing in grain size basinwards, and from suspension (medium to very fine silt). The sublittoral muds are almost exclusively deposited from suspension.

Transport by bedload occurs in larger quantities for approx. 1.5 km and in smaller quantities for approx. 3 km basinwards from the Isonzo mouth. Transport

over greater distances takes place exclusively by suspension.

The poor sorting of delta foreset beds, prodelta sediments and sublittoral mud is probably caused by addition of autochthonous skeletal material.

3. Carbonate content is high where a high input of detrital carbonate is expected: at the delta top by fluvial delivery and in the sublittoral sand by coastal erosion.

## 6. Sediment composition

The component analysis was carried out by counting statistically relevant numbers of grains in the seven wet sieve fractions  $> 250 \mu\text{m}$ . A detailed methodological discussion of this procedure can be found in SARNTHEIN (1971). On the basis of qualitative characteristics, 29 component categories have been distinguished, more than 60,000 grains having been counted. The grain numbers were subsequently expressed as percentages of each particular fraction and of the total fraction  $> 250 \mu\text{m}$ . The percentage of the fraction  $> 250 \mu\text{m}$  relative to the total sediment ranges between 0.15 % and 78.19 %, of the gravel and sand fraction between 16.17 % and 91.96 % (Table 7).

### 6.1. Component categories

Carbonate rock fragments: Clastic carbonate grains of homogenous mineral composition and smooth surface structure.

Quartzsandstone fragments: Clastic components of heterogenous mineralogical composition, quartz grains being responsible for their rough surface texture. They are generally poorly rounded.

Quartz: Clear to translucent-grey particles of variable roundness. Also included are glass splinters, deposited

by environmental pollution. Quartz and glass splinters can not be consistently distinguished by binocular microscope.

**Molluscs:** The fragments of most mollusc shells exhibit very characteristic shell structures, e.g., cross lamellar structure or a nacreous layer. Differentiation into different mollusc groups was mainly based on shell morphology:

- a) **Gastropods:** Easy to identify are fragments of columellae, apices, apertures, and siphonal canals, as well as fragments including suture lines, typical structural elements (ribs, knots, etc.) and colouration (e.g., *Monodonta*). Opercula are very characteristic and easy to identify.
- b) **Bivalves:** Easily recognized are fragments including hinge, teeth, umbo, and pallial line, but concentric and radial sculptural elements at the surface may also be very typical.
- c) **Polyplacophors:** Typical are the massive plates with shingle-like overlappings. Plates occur only isolated.
- d) **Scaphopods:** Elephant tusk-like conical tubes with longitudinal ribs or riblets.
- e) **Pteropods:** Thin shells without sculpture open at one side.

**Echinoderms:** The skeletal elements of most echinoderms are constructed by small elements of a delicate meshwork (stereom). A distinction between the different echinoderm groups is possible on the basis of component morphology:

- a) **Echinoids:** Typical fragments are those of spines, but also of different plate types (e.g., ambulacral-, interambulacral-, genital plates) and jaw elements.
- b) **Ophiurids:** Easy to identify are vertebral ossicles and arm shields. Very rare fragments of asteroids are also included in this category.
- c) **Holothurians:** This echinoderm group possesses isolated sklerites only. The studied fractions comprised sieve plates only.

**Crustaceans:** The different crustacean groups have very distinct carapax features.

- a) **Balanids:** Informal term for remnants of different cirripeds. Typical are isolated, internally hollow plates, frequently with ribs on the interior surfaces.
  - b) **Decapod crustaceans:** Informal term for remnants of different higher crustaceans. Typical are carapax, claw and limb fragments. Carapax fragments are often of black colour with a glossy surface. The outermost carapax layer often bears a honey-comb pattern, the inner parts comprising alternating light and dark layers.
  - c) **Ostracods:** Mostly isolated ovoidal valves with hinges and muscle scars, smooth as well as richly sculptured.
- Bryozoans:** Highly variable colonies, either incrusting or arborescent. Representatives of both Cyclostomata

and Cheilostomata are included. Typical characters are the shape and arrangement of zooecia and their apertures, as well as the presence of avicularias and ovicells.

**Brachiopods:** Only one single valve and one double-valved specimen of the Terebratulida was found. Classification into this order was possible by the calcareous-hyalin, punctate shell with well preserved hinge and lophophore.

**Worm tubes:** Tubular fragments of sedentary polychaetes which can be further subdivided on the basis of their wall material.

- a) **Serpulids:** Fragments of calcareous polychaete tubes include fragments that are thick walled and constructed by concentric layers, have pustular thickenings and may be smooth or sculptured.
- b) **Parchment-like tubes:** Extremely thin, soft, and skin-like polychaete tubes.
- c) **Agglutinated tubes:** Collective term for fragments of parchment-like tubes with material of different grain size agglutinated on their outside, or tubes entirely built by agglutinated grains of different size.

**Sponge spicules:** These are the only and very rare sponge remains found in the sediments of the study area. All spicules are siliceous and bear an axial canal.

**Red algae:** This category includes only crustose fragments of coralline red algae. They are of whitish colour, the upper surfaces sometimes showing hemispheroidal protuberances caused by conceptacles. The lower surface is irregular.

**Foraminifera:** Due to typical chamber shapes, fragments are also easy to identify. A further differentiation is possible on the basis of the test wall material:

- a) **Hyaline foraminifera:** Calcareous-hyaline and perforated test walls of mainly vagile benthic foraminifera are found. Tests of sessile and more rarely also planktic forms are present, the latter probably originating from reworked fossil material.
- b) **Miliolid foraminifera:** The white, opaque, imperforate and glossy tests are easy to identify. Only vagile benthic forms were found.
- c) **Agglutinated foraminifera:** Opaque, imperforate walls of agglutinated particles causing a rough surface are included in this category. They exclusively belong to vagile benthic forms.

**Vertebrate remains:** These skeletal particles exclusively originate from fishes and are represented by vertebrae and rare otoliths. The latter have a typical ovoidal outline, are massive, of whitish colour and have a distinctive furrow.

**Pellets and mud aggregates:** Most particles of this category are artificially produced by sieving and drying due to clumping of mud, producing mud aggregates with rough surfaces. Only a subordinate amount of this category are fecal pellets, which are ellipsoidal and

smooth. A clear distinction of both types was not consistently possible and they were thus grouped together.

**Plant remains:** Long-fibered, bright to dark brown serrated components of land plants make up this category.

**Tar clumps:** Black, homogeneous particles of irregular surface are incorporated in this group. EDS-analyses of these components pointed to organic material of variable Ca- and S-content. They may represent products of environmental pollution, perhaps originating from ships.

**Unidentified particles:** Included into this category are skeletal remains which could not be allocated to any one of the categories listed above due to abrasion or/and erosion.

## 6.2. Component distribution

The component categories represent two major groups: a biogenic one, which represents the autochthonous sediment portion (except for plant remains), and a non-biogenic one (carbonate rock fragments, quartzsandstone fragments, quartz, tar clumps), being carried into the marine environment by different transport mechanisms.

**Rock fragments** ( $x = 32.37\%$ ,  $s = 36.81\%$ ) are the most abundant components, contributing up to 99 % to the investigated grain size fractions (Fig. 11). Among them, carbonate rock fragments ( $x = 28.72\%$ ,  $s = 33.40\%$ ) dominate, in particular in the delta top sediments ( $x = 95.33\%$ ,  $s = 0.16\%$ ), in the delta foreset beds ( $x = 58.92\%$ ,  $s = 10.40\%$ ), and along the sublittoral sands at the cliff-coast ( $x = 47.72\%$ ,  $s = 9.54\%$ ) (Fig. 12). Their relative content increases with decreasing grain size and decreases with increasing distance from the Isonzo mouth (except for the sublittoral sand) (Fig. 13). In the sublittoral sand their relative proportion is generally very high and similar in all fractions (Fig. 13). Quartzsandstone fragments ( $x = 2.0\%$ ,  $s = 5.05\%$ ) occur in higher proportions only in the sublittoral sand ( $x = 15.67\%$ ,  $s = 0.20\%$ ), being more or less equally abundant in all fractions (Fig. 13).

**Quartz** ( $x = 1.65\%$ ,  $s = 1.93\%$ ) is generally rare (Fig. 12); it increases slightly in the two finest fractions, in particular in the sublittoral sand ( $x = 5.36\%$ ,  $s = 0.16\%$ ) and at the delta top ( $x = 4.27\%$ ,  $s = 0.55\%$ ).

**Molluscs** ( $x = 24.67\%$ ,  $s = 14.88\%$ ) are the most abundant skeletal fragments (Fig. 11). In general, all mollusc remnants decrease in abundance with decreasing grain size, as illustrated for gastropods and bivalves in Fig. 14. Mollusc fragments dominate in the sublittoral mud and in the prodelta sediments, reaching nearly 50 % in some samples. In the sublittoral sand they represent the most important skeletal category (approx. 15 % > 250  $\mu\text{m}$ ). They decrease in the delta foreset beds with decreasing distance from the Isonzo and are

quantitatively unimportant at the delta top (Fig. 11). Among the molluscs, bivalves dominate all facies ( $x = 21.91\%$ ,  $s = 13.94\%$ ). They are most abundant in the sublittoral mud ( $x = 34.10\%$ ,  $s = 4.94\%$ ) and in the prodelta sediments ( $x = 25.84\%$ ,  $s = 3.83\%$ ), whereas they rapidly decrease in the delta foreset beds approaching the Isonzo (Fig. 14). Gastropods ( $x = 2.28\%$ ,  $s = 1.76\%$ ) are equally abundant in the sublittoral sand ( $x = 5.91\%$ ,  $s = 1.20\%$ ) as the bivalves ( $x = 9.23\%$ ,  $s = 0.22\%$ ). In all other facies they are relatively unimportant (Fig. 12, 14). Scaphopods ( $x = 0.48\%$ ,  $s = 0.59\%$ ) are generally very rare and almost completely restricted to the soft bottom of the sublittoral mud ( $x = 0.94\%$ ,  $s = 0.61\%$ ) and the prodelta ( $x = 0.30\%$ ,  $s = 0.18\%$ ). Polyplacophors are extremely rare and restricted to sublittoral sand and the delta top. Pteropods are represented only by a single specimen found in the sublittoral mud.

**Echinoderms** ( $x = 20.63\%$ ,  $s = 17.14\%$ ) range second among the skeletal components (Fig. 11) and their distribution in the sieve fractions is different and characteristic for each group (see Fig. 15 for echinoids and ophiurids). Like molluscs, echinoderms are most abundant in the soft bottoms of the sublittoral mud and prodelta sediments (up to nearly 50 %; Fig. 11). In the sublittoral sand they are unimportant in all fractions ( $\leq 1\%$ ). In the delta foreset beds their abundance decreases distinctly below 1 % with decreasing distance from the Isonzo and at the delta top they are negligible.

Among the echinoderms, holothurian sklerites are very rare ( $x = 0.17\%$ ,  $s = 0.25\%$ ) and totally restricted to the finest fractions of the sublittoral mud ( $x = 0.33\%$ ,  $s = 0.29\%$ ). Echinoid fragments ( $x = 3.98\%$ ,  $s = 3.76\%$ ) are more abundant in the coarser fractions, decreasing with decreasing grain size (Fig. 15). With the exception of a few ophiurids they are the only echinoderms in the sublittoral sand ( $x = 0.45\%$ ,  $s = 0.10\%$ ), reaching their highest abundance in the sublittoral mud ( $x = 7.19\%$ ,  $s = 2.51\%$ ) and in the prodelta sediments ( $s = 3.97\%$ ,  $s = 3.12\%$ ). In these facies, however, they are surpassed by ophiurids (Fig. 12). Contrary to the echinoids, ophiurids ( $x = 16.49\%$ ,  $s = 14.90\%$ ) are most abundant in the two finest fractions (Fig. 15). They are the most abundant echinoderm group, being almost completely restricted to the sublittoral mud ( $x = 23.97\%$ ,  $s = 7.72\%$ ) and the prodelta sediments ( $x = 32.73\%$ ,  $s = 14.34\%$ ). They are extremely rare in the sublittoral sand and totally absent at the delta top. The delta foreset beds are characterized by a distinct decrease in both echinoids ( $x = 0.44\%$ ,  $s = 0.45\%$ ) and ophiurids ( $x = 2.19\%$ ,  $s = 2.65\%$ ) with decreasing distance from the Isonzo as well as decreasing grain size.

**Crustaceans** ( $x = 1.00\%$ ,  $s = 0.54\%$ ) are generally

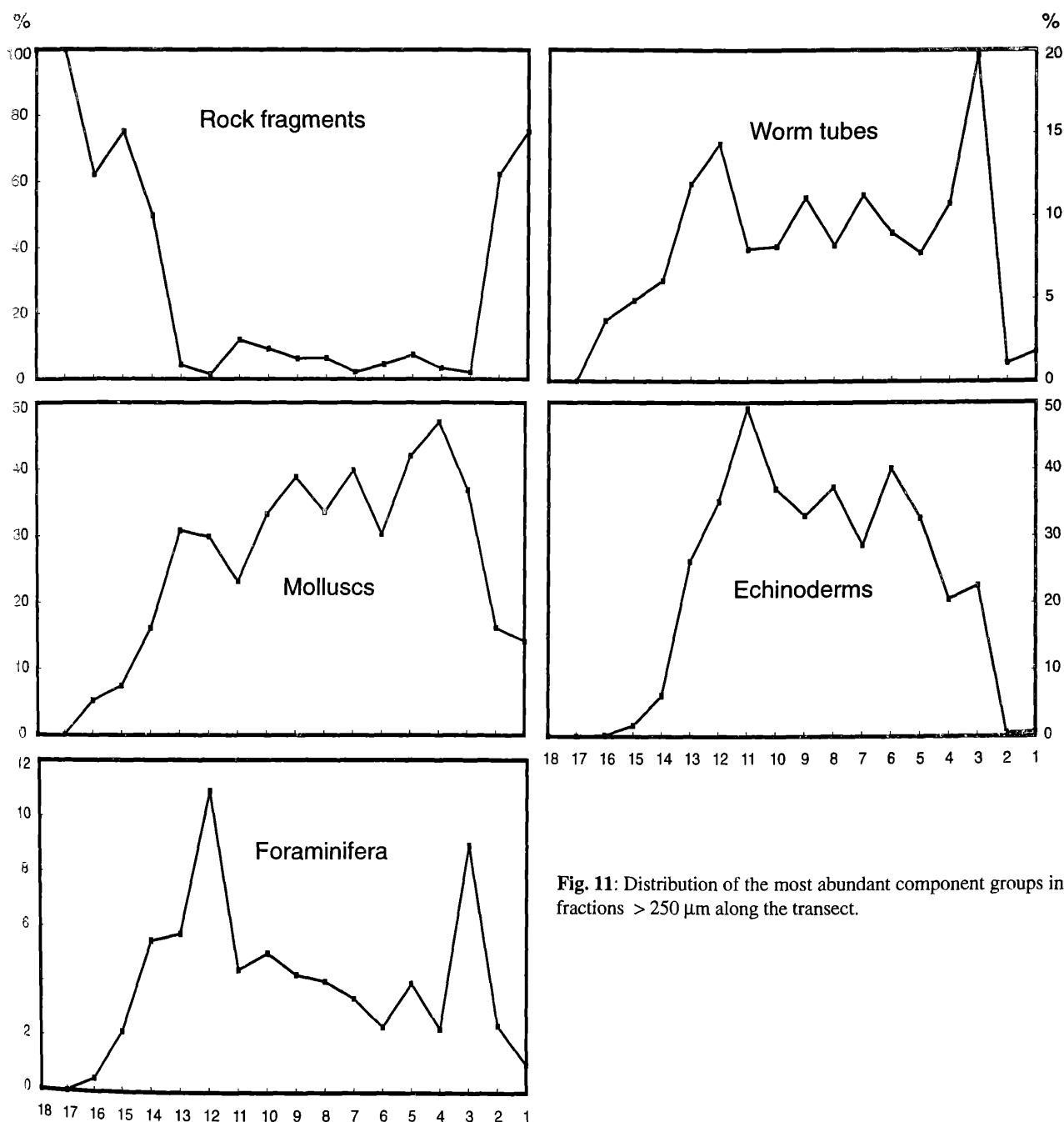

Fig. 11: Distribution of the most abundant component groups in fractions  $> 250 \mu\text{m}$  along the transect.

rare (never exceeding 2 % in the fraction  $> 250 \mu\text{m}$ ), but occur in all facies. Whereas balanids and decapod crustaceans decrease in abundance with decreasing grain size, ostracods first appear in the fourth fraction, reaching a higher abundance only in the two finest fractions. Balanids ( $x = 0.18 \%$ ,  $s = 0.23 \%$ ) and decapod crustaceans ( $x = 0.10 \%$ ,  $s = 0.18 \%$ ) are very rare throughout. For the sublittoral sand balanids ( $x = 0.69 \%$ ,  $s = 0.17 \%$ ) as well as decapod crustaceans ( $x = 0.53 \%$ ,  $s = 0.27 \%$ ) are characteristic, occurring in all fractions and reaching highest proportions in the total fraction. They occur also in the sublittoral mud, prodelta sediments and delta foreset beds, where they are inconsistently distributed in the individual size fractions, being generally unimportant, however. At the delta top

they are present only in the coarser fractions, being quantitatively unimportant. Ostracods ( $x = 0.72 \%$ ,  $s = 0.52 \%$ ) occur in all sediments except at the delta top. In the sublittoral sand they are very rare ( $x = 0.11 \%$ ,  $s = 0.08 \%$ ), but increase in the sublittoral mud ( $x = 0.99 \%$ ,  $s = 0.41 \%$ ) and in the prodelta sediments ( $x = 1.07 \%$ ,  $s = 0.28 \%$ ). They decrease once more in the delta foreset beds ( $x = 0.56 \%$ ,  $s = 0.51 \%$ ) with decreasing distance from the Isonzo.

**Bryozoa** are quantitatively unimportant ( $x = 0.12 \%$ ,  $s = 0.37 \%$ ) and are randomly distributed. They are rare in the sublittoral sand, prodelta sediments and delta foreset beds (never exceeding 1.5 %) and are absent at the delta top and also in the sublittoral mud.

**Brachiopods** were exclusively found in the sublittoral

sand, being quantitatively unimportant.

**Worm tubes** ( $x = 7.64 \%$ ,  $s = 5.23 \%$ ) are relatively abundant in all facies and all fractions. Most abundant are parchment-like tubes ( $x = 6.59 \%$ ,  $s = 4.94 \%$ ), which are typical for the sublittoral mud ( $x = 9.25 \%$ ,  $s = 4.15 \%$ ) and the prodelta sediments ( $x = 10.30 \%$ ,  $s = 2.56 \%$ ) in the very coarse to coarse sand fractions (Fig. 12, 16). Serpulids ( $x = 0.76 \%$ ,  $s = 0.78 \%$ ) generally decrease towards the finer fractions, occurring in the sublittoral sand ( $x = 0.65 \%$ ,  $s = 0.18 \%$ ), the sublittoral mud ( $x = 1.21 \%$ ,  $s = 0.86 \%$ ) and the prodelta sediments ( $x = 0.76 \%$ ,  $s = 0.72 \%$ ) (Fig. 12, 16). Their contribution to the total fraction  $> 250 \mu\text{m}$  always remains below 3%. Agglutinated tubes ( $x = 0.29 \%$ ,  $s = 0.22 \%$ ) generally increase towards the finer fractions. They occur in all sediments, always remaining quantitatively unimportant, however.

**Sponge spicules** ( $x = 0.05 \%$ ,  $s = 0.07 \%$ ) were exclusively found in the two finest fractions in a few samples only. **Red algae** ( $x = 0.35 \%$ ,  $s = 1.08 \%$ ) are restricted to the sublittoral sand ( $x = 3.14 \%$ ,  $s = 1.49 \%$ ), where they are present in all size fractions.

**Foraminifera** ( $x = 3.72 \%$ ,  $s = 2.89 \%$ ) predominantly occur in the finer fractions: The largest tests belong to the hyaline group, whereas agglutinated forms are the smallest. Foraminifera are most abundant in the sublittoral mud and in prodelta sediments reaching  $> 10 \%$  in some samples (Fig. 11). Agglutinated tests ( $x = 0.88 \%$ ,  $s = 1.10 \%$ ) are almost completely restricted to the sublittoral mud ( $x = 0.96 \%$ ,  $s = 0.55 \%$ ) and to prodelta sediments ( $x = 2.43 \%$ ,  $s = 1.87 \%$ ). Hyaline forms ( $x = 1.55 \%$ ,  $s = 1.35 \%$ ) also reach their climax in the sublittoral mud ( $x = 1.97 \%$ ,  $s = 1.53 \%$ ) and in prodelta sediments ( $x = 1.84 \%$ ,  $s = 0.89 \%$ ). However, they also occur in the sublittoral sand ( $x = 1.02 \%$ ,  $s = 0.47 \%$ ). Miliolid foraminifera ( $x = 1.29 \%$ ,  $s = 1.10 \%$ ) show a similar distribution, being relatively abundant in the sublittoral mud ( $x = 1.36 \%$ ,  $s = 0.90 \%$ ) and in prodelta sediments ( $x = 2.75 \%$ ,  $s = 1.04 \%$ ). They are also represented in the sublittoral sand ( $x = 0.66 \%$ ,  $s = 0.47 \%$ ) with highest abundance in the coarse sand fractions. A rapid decrease in abundance of all three foraminiferal groups occurs with decreasing distance from the Isonzo in the delta foreset beds (Fig. 12). Contrary to the general distribution, they are more abundant in coarse sand. At the delta top, hyaline and miliolid forms are rare occurring in the coarser fractions only.

**Vertebrate remains** ( $x = 0.01$ ,  $s = 0.02 \%$ ) were found in a few samples only, occurring in small numbers and being unimportant with respect to sediment composition.

**Pellets and mud aggregates** ( $x = 3.86 \%$ ,  $s = 4.07 \%$ ) are relatively abundant in the coarse sand fractions of the predominantly pelitic sediments. They are most

abundant in the sublittoral mud ( $x = 6.52 \%$ ,  $s = 4.43 \%$ ), but occur also – with decreasing importance – in prodelta sediments ( $x = 2.08 \%$ ,  $s = 1.32 \%$ ), in delta foreset beds ( $x = 1.78 \%$ ,  $s = 1.28 \%$ ), in the sublittoral sand ( $x = 2.81 \%$ ,  $s = 3.90 \%$ ), and at the delta top ( $x = 0.07 \%$ ,  $s = 0.09 \%$ ) (Fig. 12, 17).

**Plant remains** ( $x = 4.06 \%$ ,  $s = 7.37 \%$ ) occur in higher percentages only in delta foreset beds ( $x = 14.97 \%$ ,  $s = 10.83 \%$ ) and in prodelta sediments ( $x = 6.70 \%$ ,  $s = 9.02 \%$ ). They occur in all size fractions with a dominance in coarse sand close to the Isonzo, whereas their abundance in the finer fractions increases only with increasing distance from the river (Fig. 12, 17). In the sublittoral sand ( $x = 0.06 \%$ ,  $s = 0.08 \%$ ) they are extremely rare in the coarser fractions, rare in the finer fractions of the sublittoral mud ( $x = 0.99 \%$ ,  $s = 0.98 \%$ ) and are more or less absent at the delta top.

**Tar clumps** ( $x = 0.76 \%$ ,  $s = 0.91 \%$ ) occur in all samples except one, reaching  $> 3 \%$  in one sample only. They show no consistent distribution within the grain size fractions.

**Unidentified particles** ( $x = 0.75 \%$ ,  $s = 1.05 \%$ ) were rarely found but occur in all samples, reaching highest proportions in the sublittoral sand ( $x = 3.50 \%$ ,  $s = 0.32 \%$ ) along the cliff-coast.

In conclusion, the most abundant components  $> 250 \mu\text{m}$  are carbonate rock fragments, bivalves and ophiurids. Their distribution along the transect varies in a characteristic manner, a feature also applying to the other components. The relative amount of carbonate rock fragments increases with decreasing grain size (except in sublittoral sand) and decreases with increasing distance from the Isonzo (Fig. 12, 13). In the sublittoral sand their percentage is relatively high and remains constant throughout the studied grain size fractions. Bivalve fragments decrease in the finer fractions and are most abundant in the sublittoral mud and the prodelta sediments, as are the ophiurids. The latter, however, increase in abundance with decreasing grain size. Of local importance are quartzsandstone fragments, which are abundant in the sublittoral sand of all fractions, and plant remains which occur mainly in the coarse sand fractions of the delta foreset beds and prodelta sediments.

### 6.3. Statistical analyses

Applying a cluster analysis, using Ward's method, to the data of the 29 component categories in the 7 grain size fractions, four clusters were clearly distinguished (Fig. 6c):

Cluster 1 includes the two samples from the sublittoral sand. It is characterized by carbonate rock fragments ( $x = 47.72 \%$ ,  $s = 9.54 \%$ ) and quartzsandstone fragments ( $x = 15.67 \%$ ,  $s = 0.20 \%$ ). All other categories



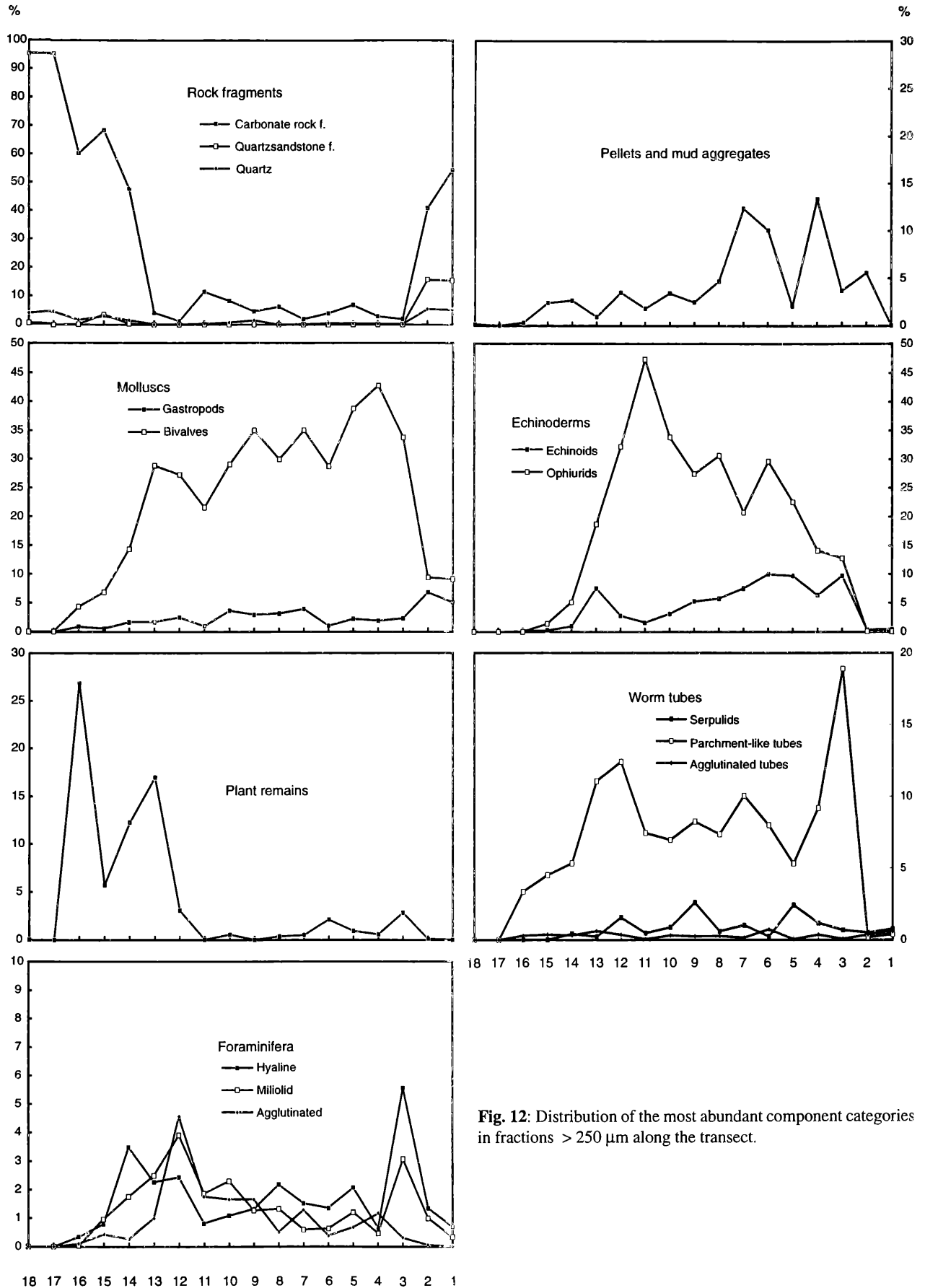

Fig. 12: Distribution of the most abundant component categories in fractions > 250 µm along the transect.

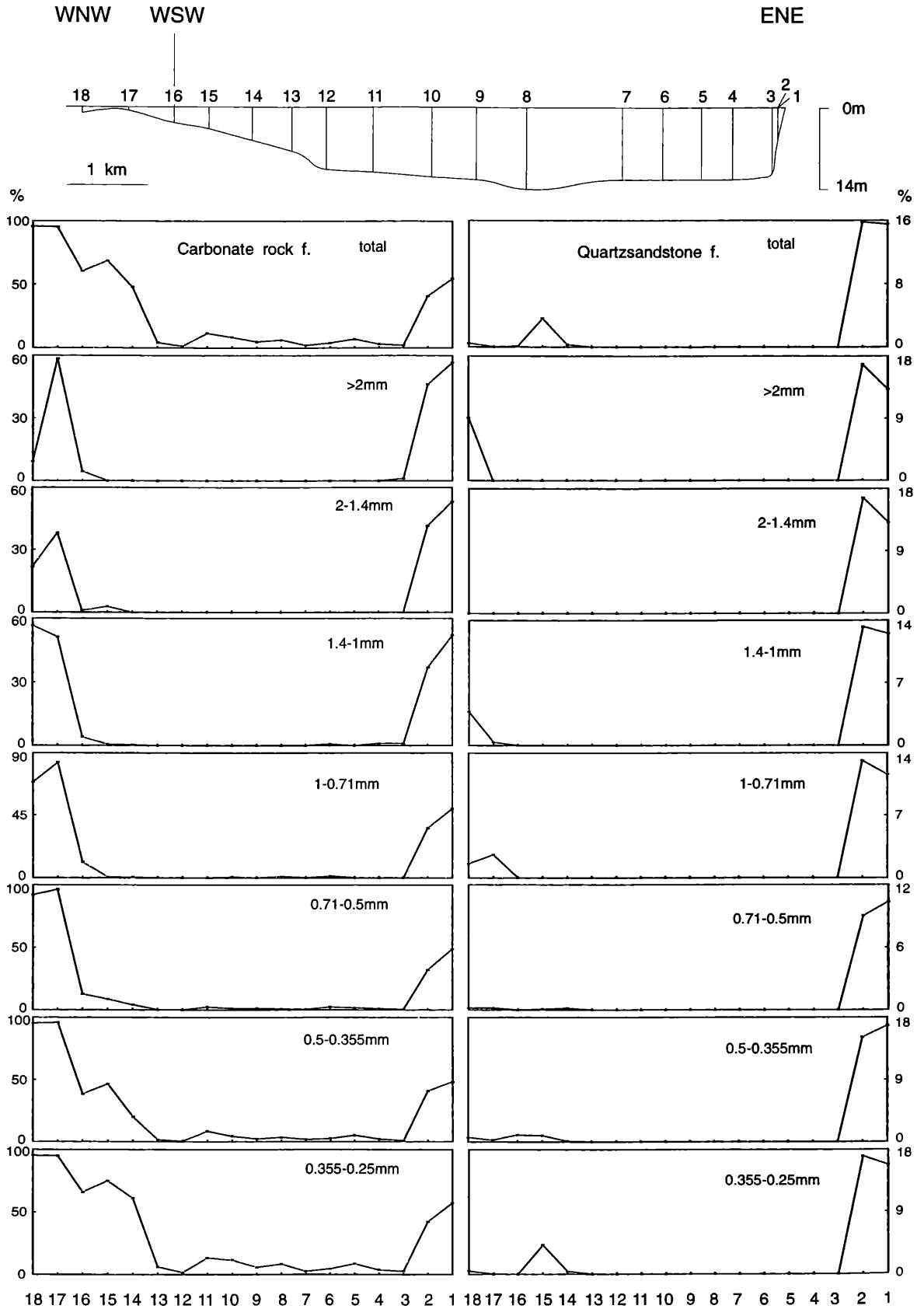

Fig. 13: Distribution of carbonate rock fragments and quartzsandstone fragments in the sediment fraction > 250 μm and in each sieve fraction.

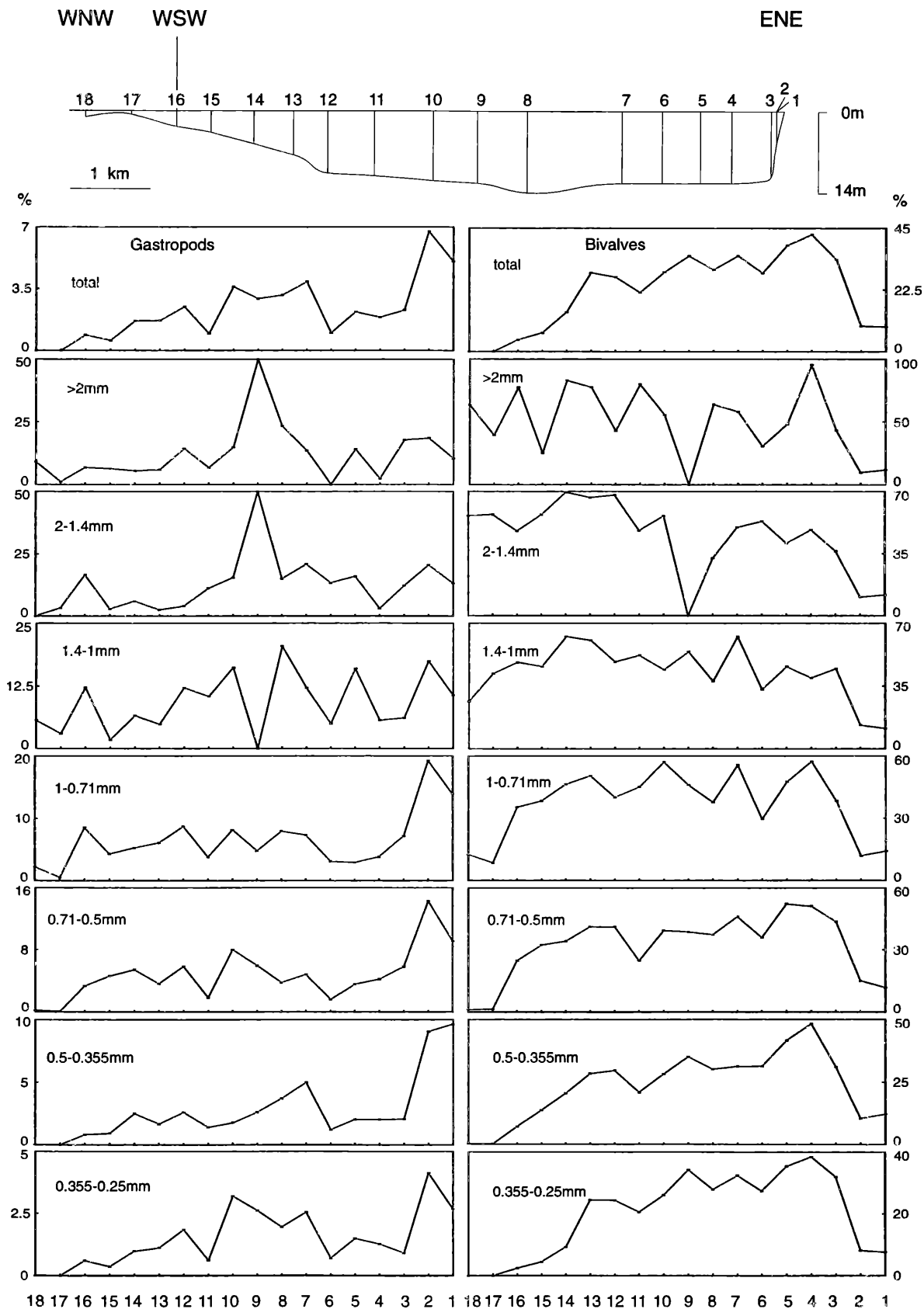

Fig. 14: Distribution of gastropods and bivalves in the sediment fraction  $> 250 \mu\text{m}$  and in each sieve fraction.

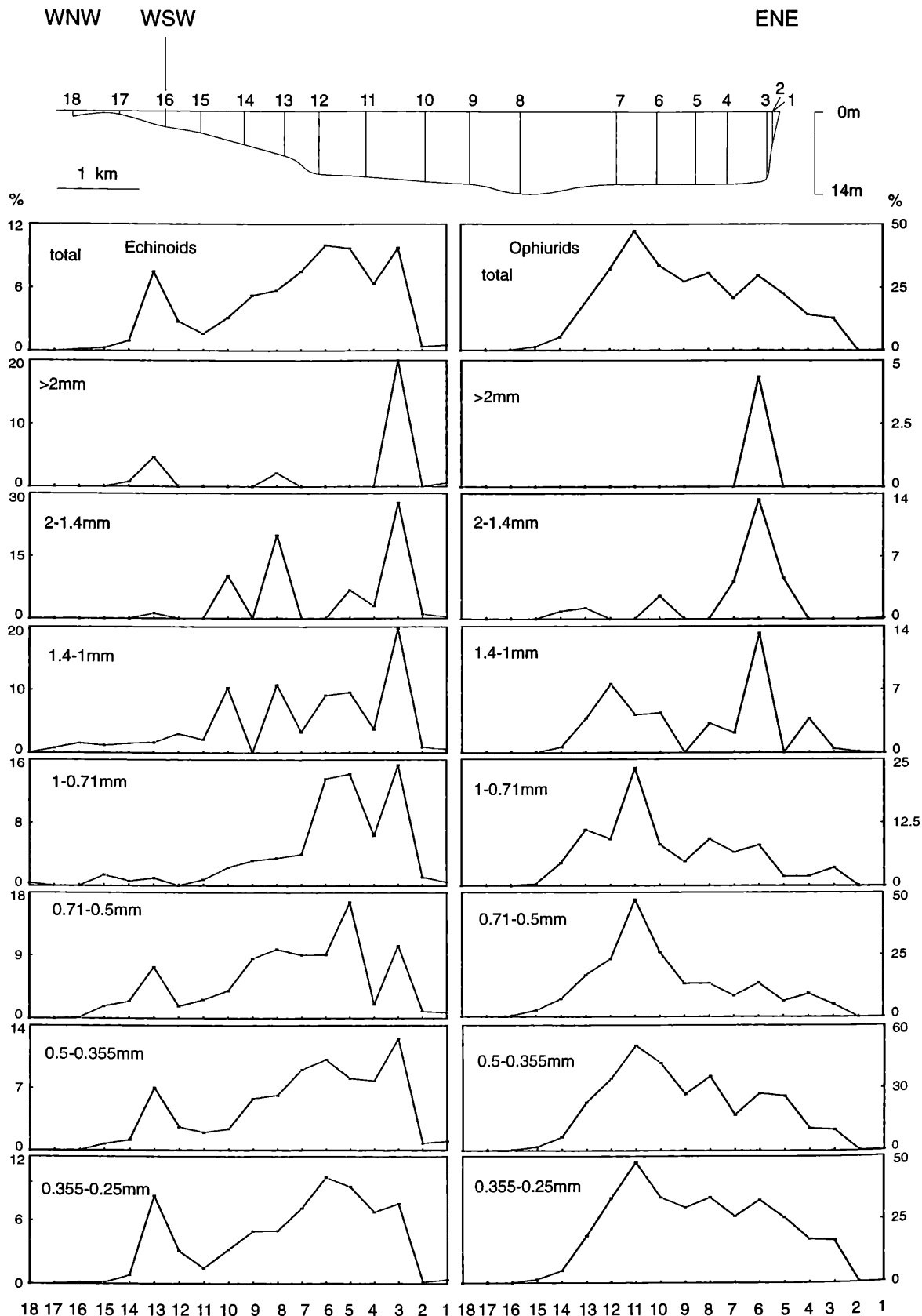

Fig. 15: Distribution of echinoids and ophiurids in the sediment fraction  $> 250 \mu\text{m}$  and in each sieve fraction.

remain below 10 %. Bivalves ( $x = 9.23$  %,  $s = 0.22$  %) rank first among skeletal fragments.

Cluster 2 comprises the two samples from the delta top, being dominated by carbonate rock fragments ( $x = 95.33$  %,  $s = 0.16$  %); skeletal particles are almost completely absent.

Cluster 3 unites the three samples of the delta foreset beds. It is dominated by carbonate rock fragments ( $x = 58.92$  %,  $s = 10.40$  %) and plant remains ( $x = 14.97$  %,  $s = 10.83$  %). All other categories remain below 10 %. Bivalves ( $x = 8.51$  %,  $s = 5.21$  %) dominate the skeletal remains.

Cluster 4 includes the eight samples from the sublittoral mud and the three samples from the prodelta sediments. Characteristic particles are bivalve ( $x = 31.85$  %,  $s = 5.91$  %) and ophiurid ( $x = 26.36$  %,  $s = 9.98$  %) fragments. All other particles remain below 10 %, parchment-like tubes being the relatively most abundant components ( $x = 9.53$  %,  $s = 3.69$  %).

To detect potential relationships between component categories, between components and grain size fractions, as well as between components and carbonate content, a correlation analysis (Pearson-correlation coefficient) was computed. Included were 24 component categories of the total fraction  $> 250$   $\mu\text{m}$ , all grain size fractions and the carbonate content. Due to their quantitative unimportance, polyplacophors, pteropods, brachiopods, sponge spicules, and vertebrate remains were not included. No significant correlations were detected for bryozoans and agglutinated worm tubes.

The analysis between component categories (Table 4) detected a group of skeletal components that dominate the sublittoral sand along the cliff-coast, including gastropods, balanids, decapod crustaceans, red algae, and unidentified particles. These components are strongly positively correlated to each other and to quartzsandstone fragments. No negative coefficients exist, except between quartzsandstone fragments and ostracods as well as parchment-like tubes.

A second group of – predominantly skeletal – components includes bivalves, scaphopods, echinoids, ophiurids, holothurians, ostracods, serpulids, parchment-like tubes, all three foraminiferal groups, as well as pellets and mud aggregates. This group prevails on soft bottoms, is subordinate or missing in the sublittoral sand and disappears with decreasing distance from the Isonzo. Significant high and very high negative correlations of all these components exist with carbonate rock fragments, being mostly also negatively correlated with quartz (exceptions are holothurians, serpulids, hyaline foraminifera, and pellets and mud aggregates). Between the components of this group no negative correlations exist. Some components, however, do not show any significant correlations at all. Bivalves,

for example, are highly positively correlated to all components, except for foraminifera; echinoids and ophiurids are not significantly correlated to each other, and the three foraminiferal groups show positive correlations to different categories.

Plant remains represent a group of their own, showing no significant correlation to any other category.

Among rock fragments strong positive correlations exist between carbonate rock fragments and quartz, both occurring in higher abundance in the sublittoral sand and with decreasing distance from the Isonzo. Both categories are not significantly correlated to quartzsandstone fragments, which occur nearly exclusively in the sublittoral sand.

Tar clumps, which are genetically obscure, are significantly correlated with gastropods and holothurians.

With respect to grain size, only tar clumps show no significant correlation among all the included component categories (Table 5). Rock fragments and quartz are all significantly or highly significantly correlated to the coarser fractions ( $< 5 \phi$ ) and negatively to the finer fractions ( $> 5.5 \phi$ ), reflecting the increase of such particles with increasing grain size. Among skeletal particles, all those dominating in sublittoral sand (gastropods, balanids, decapod crustaceans, red algae, unidentified particles) are significantly highly or very highly correlated with the coarse fractions ( $< 1.5 \phi$ ). Most of these components, however, also occur on soft bottoms and are therefore not significantly negatively correlated to the fine fractions (except unidentified grains). An exception are those components that are restricted to soft bottoms (bivalves, scaphopods, echinoids, ophiurids, holothurians, ostracods, serpulids, parchment-like tubes, all three foraminiferal groups, pellets and mud aggregates). These are highly positively or positively correlated to the fine fractions ( $> 5.5 \phi$ ) and significantly negatively correlated to the coarse fractions ( $0.5$ – $3.5 \phi$ ). Hyaline foraminifera, by contrast, are not significantly correlated to the finer grain size fractions. Again, plant remains form a group of their own, being highly positively or positively correlated to grain size fractions between  $4$ – $6.5 \phi$ . This reflects a dominance of these grain sizes in the delta foreset beds and in prodelta sediments, where plant remains are most abundant.

Carbonate content is significantly positively correlated with the coarse fractions ( $< 4 \phi$ ), carbonate rock fragments and quartz, but significantly negatively correlated with the finer fractions ( $> 6 \phi$ ) and components of the soft bottom, with the exception of foraminifera and serpulids. No significant correlations exist between carbonate contents and characteristic components of the sublittoral sand.

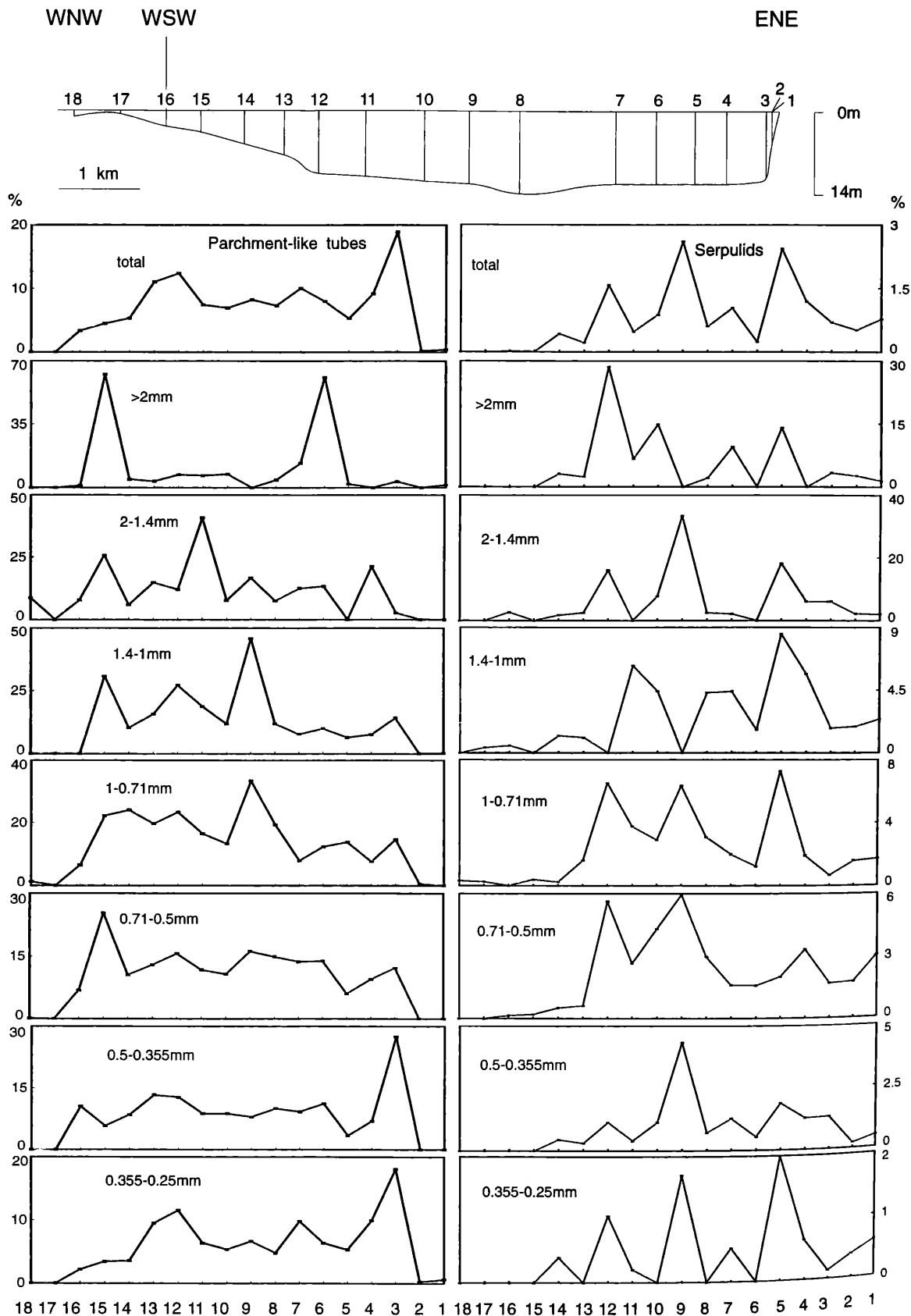

Fig. 16: Distribution of parchment-like tubes and serpulids in the sediment fraction  $> 250 \mu\text{m}$  and in each sieve fraction.

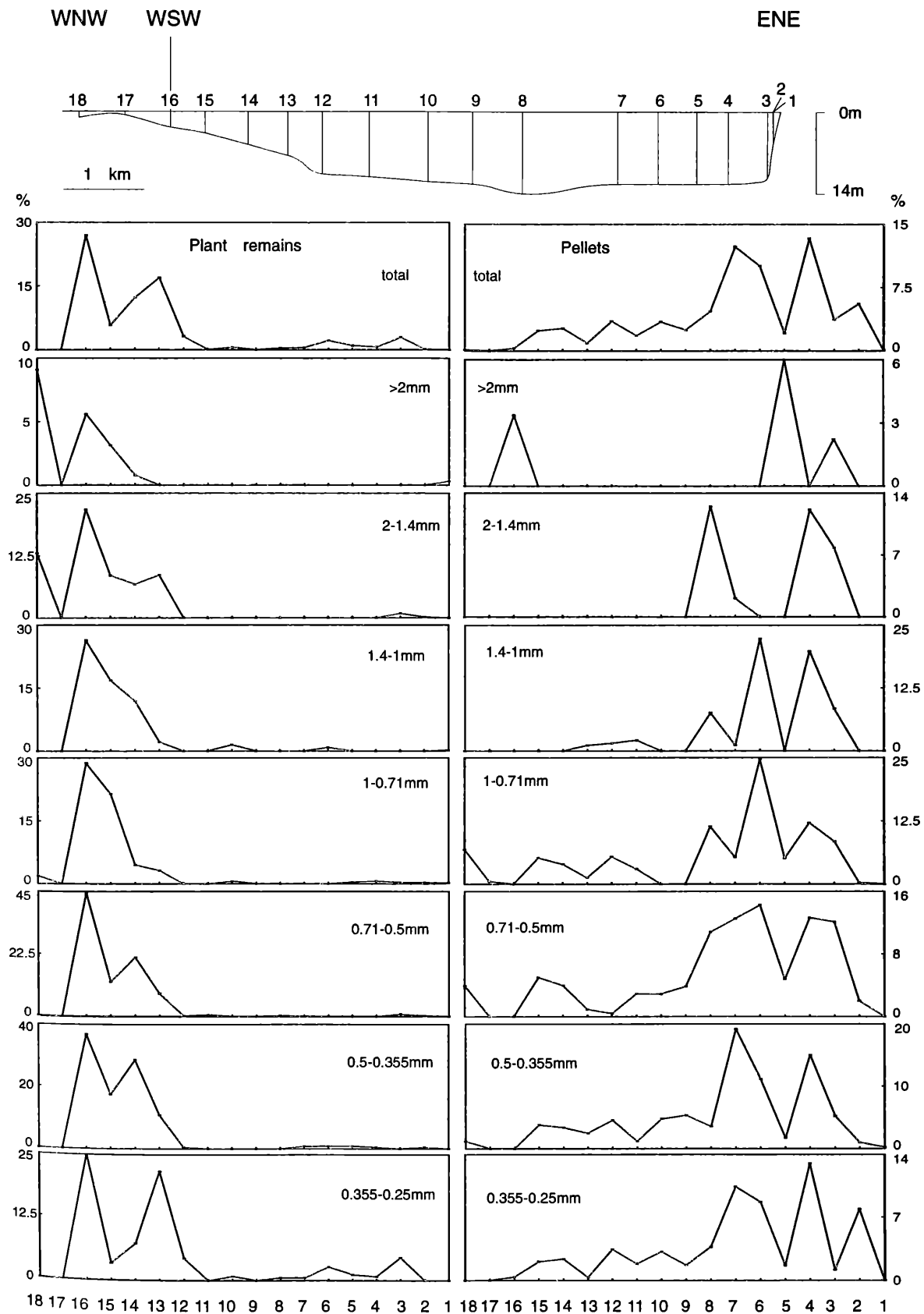

Fig. 17: Distribution of plant remains and pellets and mud aggregates in the sediment fraction > 250 μm and in each sieve fraction.

carbonate rock f.	1.000	0.273	0.802	-0.331	-0.932	-0.597	-0.769	-0.770	-0.499	-0.134	0.037	-0.732	-0.146	-0.570	-0.774	-0.244	0.172	-0.497	-0.585	-0.537	-0.527	0.147	-0.392	0.042
quartzsandstone f.	0.273	1.000	0.741	0.702	-0.391	-0.333	-0.396	-0.456	-0.282	0.747	0.862	-0.477	0.165	-0.103	-0.494	0.338	0.932	-0.171	-0.226	-0.307	-0.115	-0.184	0.140	0.926
quartz	0.802	0.741	1.000	0.212	-0.796	-0.532	-0.697	-0.737	-0.468	0.362	0.544	-0.739	-0.019	-0.328	-0.808	-0.012	0.667	-0.462	-0.534	-0.504	-0.390	-0.143	-0.138	0.574
gastropods	-0.331	0.702	0.212	1.000	0.211	0.038	0.042	0.013	0.123	0.733	0.800	0.112	0.159	0.336	-0.030	0.265	0.761	0.163	0.134	0.063	0.234	-0.295	0.526	0.806
bivalves	-0.932	-0.391	-0.796	0.211	1.000	0.794	0.848	0.668	0.509	0.127	-0.119	0.679	0.041	0.672	0.743	0.092	-0.310	0.450	0.437	0.443	0.591	-0.247	0.396	-0.196
scaphopods	-0.597	-0.333	-0.532	0.038	0.794	1.000	0.604	0.340	0.246	0.151	-0.050	0.338	-0.165	0.510	0.463	-0.072	0.275	0.108	0.008	0.183	0.689	-0.292	0.282	-0.260
echinoids	-0.769	-0.396	-0.697	0.042	0.848	0.604	1.000	0.466	0.498	0.102	-0.200	0.457	0.127	0.431	0.702	0.137	-0.324	0.520	0.279	0.112	0.515	-0.146	0.313	-0.236
ophiurids	-0.770	-0.456	-0.697	0.013	0.668	0.340	0.466	1.000	0.577	-0.195	-0.295	0.734	-0.047	0.420	0.527	0.005	-0.377	0.167	0.522	0.646	0.245	-0.292	0.172	-0.234
holothurians	-0.499	-0.292	-0.468	0.123	0.509	0.246	0.498	0.577	1.000	-0.120	-0.061	0.578	-0.237	0.374	0.184	-0.003	-0.231	0.098	0.025	0.146	0.304	-0.312	0.558	-0.110
balanids	-0.134	0.747	0.362	0.733	0.127	0.151	0.102	-0.195	-0.120	1.000	0.707	-0.304	0.036	0.323	-0.089	0.157	0.680	0.151	-0.032	-0.216	0.029	-0.356	0.372	0.805
decapods	0.037	0.862	0.544	0.800	-0.119	-0.050	-0.200	-0.295	-0.061	0.707	1.000	-0.264	0.169	0.088	-0.404	0.245	0.952	-0.100	-0.171	-0.234	0.123	-0.250	0.430	0.884
ostracods	-0.732	-0.477	-0.739	0.112	0.679	0.338	0.457	0.734	0.578	-0.304	-0.264	1.000	0.206	0.386	0.504	0.172	-0.391	0.298	0.434	0.439	0.277	0.040	0.269	-0.306
bryozoa	-0.146	0.165	-0.019	0.159	0.041	-0.165	0.127	-0.047	-0.237	0.036	0.169	0.206	1.000	-0.186	0.099	0.464	0.211	0.094	0.253	-0.020	-0.180	0.370	-0.115	0.160
serpulids	-0.570	-0.103	-0.328	0.336	0.672	0.510	0.431	0.420	0.374	0.323	0.088	0.386	-0.186	1.000	0.296	-0.150	-0.068	0.196	0.274	0.488	0.163	-0.355	0.326	0.146
parchment-like tubes	-0.774	-0.494	-0.808	-0.030	0.743	0.463	0.702	0.527	0.184	-0.089	-0.404	0.504	0.099	0.296	1.000	0.052	-0.440	0.739	0.724	0.488	0.360	0.031	0.230	-0.368
agglutinated tubes	-0.244	0.338	-0.012	0.265	0.092	-0.072	0.137	0.005	-0.003	0.157	0.245	0.172	0.464	-0.150	0.052	1.000	0.255	-0.012	0.067	0.029	0.232	0.266	-0.129	0.300
red algae	0.172	0.932	0.667	0.761	-0.310	-0.275	-0.324	-0.377	-0.231	0.680	0.952	-0.391	0.211	-0.068	-0.440	0.255	1.000	-0.107	-0.159	-0.261	-0.010	-0.186	0.265	0.925
hyaline forams	-0.497	-0.271	-0.462	0.163	0.450	0.108	0.520	0.167	0.098	0.151	-0.100	0.298	0.196	0.196	0.739	-0.012	-0.107	1.000	0.705	0.124	0.070	0.074	0.393	-0.066
mililid forams	-0.585	-0.226	-0.534	0.134	0.437	0.008	0.279	0.522	0.025	-0.032	-0.171	0.434	0.253	0.274	0.724	0.067	-0.159	0.705	1.000	0.680	0.085	0.014	0.177	-0.079
agglutinated forams	-0.537	-0.307	-0.504	0.063	0.443	0.183	0.112	0.646	0.146	-0.216	-0.234	0.439	-0.020	0.488	0.488	0.029	-0.261	0.124	0.680	1.000	0.147	-0.144	-0.091	-0.150
pellets and mud aggr.	-0.527	-0.115	-0.390	0.234	0.591	0.689	0.515	0.245	0.304	0.029	0.123	0.277	-0.180	0.163	0.360	0.232	-0.010	0.070	-0.085	0.147	1.000	-0.292	0.184	-0.126
plant remains	0.147	-0.184	-0.143	-0.295	-0.247	-0.292	-0.146	-0.292	-0.312	-0.356	-0.250	0.040	0.370	-0.355	0.031	0.266	-0.186	0.074	0.014	-0.144	-0.292	1.000	-0.318	-0.189
tar clumps	-0.392	0.140	-0.138	0.526	0.396	0.282	0.313	0.172	0.558	0.372	0.430	0.269	-0.115	0.326	0.230	-0.129	0.265	0.393	0.177	-0.091	0.184	-0.318	1.000	0.288
unidentified grains	0.042	0.926	0.574	0.806	-0.196	-0.260	-0.236	-0.234	-0.110	0.805	0.884	-0.306	0.160	0.146	-0.368	0.300	0.925	-0.066	-0.079	-0.150	-0.126	-0.189	0.288	1.000

Table 4: Correlation coefficients between component categories. Bold types = 1 % significance level, underlined type = 5 % significance level.



phi	carbonate rock f.	quartzsandstone f.	quartz	gastropods	bivalves	scaphopods	echinoids	ophiurids	holothurians	balanids	decapods	ostracods	bryozoa	serpulids	parchment-like tubes	agglutinated tubes	red algae	hyaline forams	milloid forams	agglutinated forams	pellets	plant remains	tar clumps	unidentified grains
-1	0.349	<u>0.797</u>	<u>0.728</u>	0.564	-0.424	-0.300	-0.391	-0.516	-0.281	<u>0.525</u>	<u>0.830</u>	-0.425	0.284	-0.214	-0.538	0.159	<u>0.869</u>	-0.173	-0.275	-0.386	-0.110	-0.081	0.177	<u>0.751</u>
-0.5	0.212	<u>0.974</u>	<u>0.705</u>	0.758	-0.343	-0.302	-0.347	-0.418	-0.258	<u>0.748</u>	<u>0.921</u>	-0.429	0.200	-0.078	-0.464	0.289	<u>0.981</u>	-0.117	-0.191	-0.297	-0.073	-0.176	0.213	<u>0.952</u>
0	0.231	<u>0.983</u>	<u>0.721</u>	0.744	-0.353	-0.304	-0.356	-0.425	-0.262	<u>0.767</u>	<u>0.897</u>	-0.444	0.189	-0.075	-0.479	0.302	<u>0.961</u>	-0.140	-0.211	-0.300	-0.093	-0.190	0.181	<u>0.951</u>
0.5	0.288	<u>0.976</u>	<u>0.760</u>	<u>0.697</u>	-0.394	-0.326	-0.384	-0.449	-0.275	<u>0.765</u>	<u>0.850</u>	-0.480	0.167	-0.091	-0.516	0.287	<u>0.922</u>	-0.181	-0.251	-0.317	-0.139	-0.214	0.127	<u>0.929</u>
1	0.419	<u>0.924</u>	<u>0.837</u>	<u>0.582</u>	-0.490	-0.372	-0.447	-0.512	-0.316	<u>0.700</u>	<u>0.769</u>	-0.563	0.132	-0.153	-0.590	0.193	<u>0.858</u>	-0.257	-0.327	-0.362	-0.212	-0.244	0.051	<u>0.852</u>
1.5	<u>0.746</u>	0.375	<u>0.796</u>	-0.063	-0.666	-0.404	-0.510	-0.555	-0.342	0.163	0.205	-0.653	-0.038	-0.335	-0.651	-0.237	0.317	-0.441	-0.485	-0.397	-0.379	-0.255	-0.228	0.241
2	<u>0.803</u>	0.141	<u>0.692</u>	-0.290	-0.678	-0.384	-0.494	-0.527	-0.324	0.004	0.004	-0.629	-0.092	-0.382	-0.620	-0.391	0.112	-0.465	-0.494	-0.377	-0.388	-0.234	-0.288	-0.007
2.5	<u>0.820</u>	0.275	<u>0.747</u>	-0.199	-0.716	-0.423	-0.539	-0.582	-0.358	0.038	0.093	-0.673	-0.077	-0.386	-0.665	-0.308	0.209	-0.474	-0.517	-0.412	-0.410	-0.216	-0.286	0.114
3	<u>0.741</u>	<u>0.582</u>	<u>0.796</u>	0.081	-0.721	-0.476	-0.592	-0.655	-0.409	0.279	0.356	-0.694	-0.016	-0.367	-0.680	-0.058	0.475	-0.412	-0.485	-0.449	-0.378	-0.093	-0.194	0.415
3.5	<u>0.552</u>	<u>0.846</u>	<u>0.797</u>	0.424	-0.632	-0.491	-0.596	-0.675	-0.441	0.440	<u>0.698</u>	-0.565	0.072	-0.318	-0.602	0.197	<u>0.792</u>	-0.151	-0.290	-0.446	-0.223	0.015	-0.001	<u>0.677</u>
4	<u>0.488</u>	<u>0.486</u>	<u>0.488</u>	0.174	-0.594	-0.469	-0.546	-0.675	-0.469	0.152	0.387	-0.412	-0.016	-0.385	-0.408	0.145	<u>0.478</u>	0.030	-0.232	-0.455	-0.261	<u>0.557</u>	-0.066	0.388
5	0.363	0.009	0.095	-0.241	-0.426	-0.344	-0.371	-0.494	-0.384	-0.249	-0.115	-0.195	-0.026	-0.390	-0.126	0.129	-0.049	0.090	-0.103	-0.297	-0.256	<u>0.801</u>	-0.223	-0.107
5.5	0.018	-0.006	-0.142	-0.167	-0.096	-0.221	-0.026	-0.269	-0.383	-0.043	-0.255	0.019	0.340	-0.258	0.291	0.409	-0.177	0.412	0.296	-0.095	-0.291	<u>0.709</u>	-0.240	-0.108
6	-0.219	-0.398	-0.503	-0.336	0.141	-0.043	0.151	0.052	-0.193	-0.412	-0.458	0.295	0.287	-0.146	0.521	0.201	-0.428	0.457	0.459	-0.154	-0.102	<u>0.715</u>	-0.172	-0.431
6.5	-0.428	-0.507	-0.687	-0.301	0.338	0.077	0.285	0.304	0.009	-0.465	-0.496	0.512	0.306	0.005	0.606	0.248	-0.510	0.427	0.536	0.337	0.007	<u>0.638</u>	-0.130	-0.474
7	-0.660	-0.600	-0.855	-0.233	<u>0.571</u>	0.264	0.433	<u>0.590</u>	0.212	-0.432	-0.508	<u>0.683</u>	0.190	0.219	<u>0.731</u>	0.209	-0.569	0.442	<u>0.639</u>	<u>0.541</u>	0.149	0.421	-0.013	-0.484
7.5	-0.767	-0.624	-0.908	-0.165	<u>0.701</u>	0.386	<u>0.514</u>	<u>0.736</u>	0.352	-0.390	-0.484	<u>0.762</u>	0.089	0.372	<u>0.741</u>	0.158	-0.579	0.393	<u>0.628</u>	<u>0.632</u>	0.262	0.226	0.050	-0.471
8	-0.851	-0.626	-0.941	-0.088	<u>0.806</u>	<u>0.509</u>	<u>0.610</u>	<u>0.826</u>	0.475	-0.304	-0.440	<u>0.780</u>	-0.025	0.452	<u>0.762</u>	0.093	-0.562	0.378	<u>0.583</u>	<u>0.635</u>	0.389	0.051	0.158	-0.445
8.5	-0.862	-0.618	-0.928	-0.062	<u>0.839</u>	<u>0.562</u>	<u>0.636</u>	<u>0.849</u>	<u>0.535</u>	-0.270	-0.412	<u>0.787</u>	-0.078	0.513	<u>0.724</u>	0.056	-0.552	0.332	<u>0.522</u>	<u>0.619</u>	0.430	-0.035	0.191	-0.428
9	-0.865	-0.615	-0.924	-0.058	<u>0.850</u>	<u>0.584</u>	<u>0.654</u>	<u>0.849</u>	<u>0.562</u>	-0.254	-0.399	<u>0.795</u>	-0.100	0.517	<u>0.718</u>	0.054	-0.547	0.331	<u>0.496</u>	<u>0.589</u>	0.447	-0.058	0.222	-0.422
9.5	-0.867	-0.609	-0.920	-0.045	<u>0.853</u>	<u>0.593</u>	<u>0.666</u>	<u>0.851</u>	<u>0.574</u>	-0.245	-0.394	<u>0.783</u>	-0.111	0.501	<u>0.713</u>	0.050	-0.541	0.319	<u>0.470</u>	<u>0.566</u>	0.477	-0.081	0.230	-0.422
10	-0.861	-0.621	-0.928	-0.065	<u>0.857</u>	<u>0.603</u>	<u>0.677</u>	<u>0.817</u>	<u>0.559</u>	-0.248	-0.408	<u>0.779</u>	-0.115	0.504	<u>0.735</u>	0.048	-0.557	0.361	<u>0.474</u>	<u>0.540</u>	0.469	-0.046	0.240	-0.439
10.5	-0.869	-0.613	-0.921	-0.035	<u>0.871</u>	<u>0.610</u>	<u>0.706</u>	<u>0.817</u>	<u>0.590</u>	-0.222	-0.392	<u>0.781</u>	-0.124	0.513	<u>0.726</u>	0.050	-0.545	0.361	<u>0.454</u>	<u>0.516</u>	0.491	-0.077	0.269	-0.427
11	-0.861	-0.600	-0.907	-0.035	<u>0.883</u>	<u>0.666</u>	<u>0.736</u>	<u>0.788</u>	<u>0.594</u>	-0.175	-0.365	<u>0.742</u>	-0.162	0.504	<u>0.721</u>	0.016	-0.529	0.367	0.398	0.436	<u>0.523</u>	-0.107	0.316	-0.419
<11	-0.857	-0.574	-0.879	-0.004	<u>0.901</u>	<u>0.692</u>	<u>0.809</u>	<u>0.724</u>	<u>0.618</u>	-0.126	-0.333	<u>0.689</u>	-0.186	0.516	<u>0.718</u>	0.042	-0.500	0.382	0.335	0.377	<u>0.599</u>	-0.135	0.336	-0.395
CaCO3	<u>0.866</u>	0.444	<u>0.857</u>	-0.096	-0.843	-0.612	-0.714	-0.647	-0.500	0.049	0.228	-0.662	0.121	-0.468	-0.731	-0.153	0.379	-0.458	-0.408	-0.374	-0.540	-0.070	-0.340	0.263

Table 5: Correlation coefficients between component categories and grain size fractions and carbonate contents respectively.

Bold types = 1 % significance level, underlined type = 5 % significance level.

### 6.3.1. Conclusion

Correlation analysis produced five component groups: (a) Quartsandstone fragments, gastropods, balanids, decapod crustaceans, red algae, and unidentified grains are highly positively correlated to each other and exhibit no negative correlations to any other category. They are significantly positively correlated to the coarse fractions ( $< 1.5 \phi$ ) but show no correlation to carbonate content. (b) Bivalves, scaphopods, echinoids, ophiurids, holothurians, ostracods, serpulids, parchment-like tubes, hyaline, miliolid and agglutinated foraminifera as well as pellets and mud aggregates are all negatively correlated to carbonate rock fragments and mostly also to quartz. High positive correlations exist to the fine fractions ( $> 5.5 \phi$ ) negative ones to the fractions between  $0.5 - 3.5 \phi$ . All components are negatively correlated with carbonate content.

(c) Plant remains show no significant correlation to any other component category including carbonate content. Only to the grain size fractions between  $4 - 6.5 \phi$  a high positive correlation is observed.

(d) Carbonate rock fragments and quartz are significantly positively correlated to each other, to carbonate content and to the coarse fractions ( $1.5 - 4 \phi$ ). Negative correlations are observed to the fine fractions ( $> 6.5 \phi$ ) and to all or most components of group (b).

(e) Bryozoa, agglutinated tubes, and tar clumps show no significant correlations to carbonate content or to grain size and only a few correlations to other components.

### 6.4. Component facies

Based on the cluster analysis (Chapter 6.3.), the following component facies were differentiated: Component Cluster 1 comprises two samples (AU1, AU2) dominated

by carbonate rock fragments and quartsandstone fragments. The components of group (a) occur predominantly or exclusively in this cluster, which was designated as **Component Facies 1** (Fig. 18). Component group (b) is predominantly represented in the eleven samples (AU3–AU13) of Cluster 4, dominated by bivalves and ophiurids, together comprising **Component Facies 2**. Plant remains are a group of their own occurring mainly in samples AU14–AU16 of Cluster 3 together with carbonate rock fragments, making up **Component Facies 3**. Cluster 2 is characterized by carbonate rock fragments and quartz (component group (d)) and includes samples AU17 and AU18. This cluster was assigned **Component Facies 4**, being clearly dominated by carbonate rock fragments. Component group (e) was not found to be indicative of any facies.

### 6.5. Interpretation

Grouping of component categories by cluster analysis correlates well with results of the sedimentological analyses. The component facies exhibit the same pattern as that of the sedimentary facies: Sublittoral sand samples are dominated by carbonate rock fragments and quartsandstone fragments, delta top samples only by carbonate rock fragments. Delta foreset beds are characterized by carbonate rock fragments together with plant remains and the sublittoral mud and prodelta sediments by bivalves and ophiurids, respectively.

The component analysis clearly shows that components typical for the sublittoral sand rapidly decrease in abundance with increasing distance from the coast. Particles produced by coastal erosion (carbonate rock fragments, quartsandstone fragments) are evenly distributed in all the studied grain size fractions, pointing

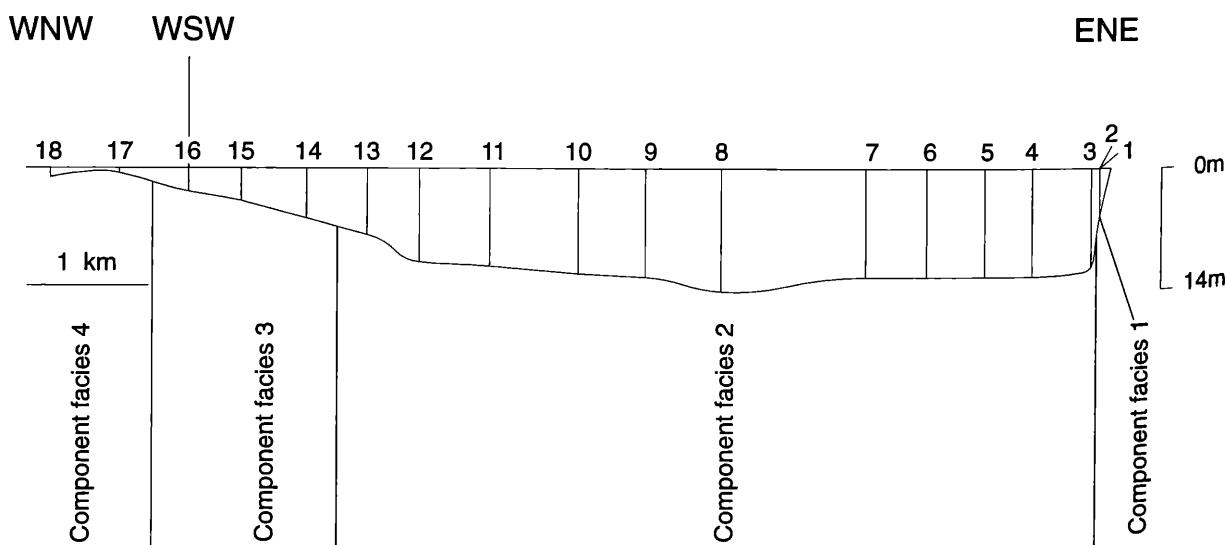

Fig. 18: Distribution of component facies along the transect.

	factor 1	factor 2	factor 3
carbonate rock f.	<b>-0.97605</b>	-0.09577	0.02983
10 - 10.5	<b>0.93698</b>	-0.31647	-0.04525
CaCO <sub>3</sub>	<b>-0.93421</b>	0.12899	-0.13821
bivalves	<b>0.93314</b>	-0.02753	-0.19381
9.5 - 10	<b>0.93195</b>	-0.33467	-0.00453
9 - 9.5	<b>0.93064</b>	-0.32395	-0.04840
8.5 - 9	<b>0.93044</b>	-0.33027	-0.02246
10.5 - 11	<b>0.93037</b>	-0.29782	-0.08101
8 - 8.5	<b>0.92514</b>	-0.33964	0.00449
>11	<b>0.91942</b>	-0.26089	-0.12891
7.5 - 8	<b>0.91268</b>	-0.35712	0.10931
2 - 2.5	<b>-0.88146</b>	-0.01654	-0.38045
1.5 - 2	<b>-0.85426</b>	-0.12522	-0.44346
quartz	<b>-0.84264</b>	0.47079	-0.10553
7 - 7.5	<b>0.83634</b>	-0.39981	0.30847
1 - 1.5	<b>-0.81603</b>	0.13664	-0.39963
2.5 - 3	<b>-0.80135</b>	0.29176	-0.10583
ophiurids	<b>0.77398</b>	-0.22482	-0.25293
parchment-like tubes	<b>0.76546</b>	-0.23079	0.18886
ostracods	<b>0.76369</b>	-0.19822	0.04529
echinoids	<b>0.74338</b>	-0.08986	-0.15635
6.5 - 7	<b>0.72853</b>	-0.41804	0.51334
scaphopods	<b>0.61710</b>	-0.08028	-0.34796
serpulids	0.59314	0.15082	-0.33111
miliolid forams	0.56175	-0.02556	0.31003
holothurians	0.55407	-0.07029	-0.40932
agglutinated forams	0.53431	-0.17024	-0.04834
pellets and mud aggr.	0.52813	0.09669	-0.26238
hyaline forams	0.48758	0.06938	0.34062
tar clumps	0.41731	0.41103	-0.22168
unidentified particles	-0.14214	<b>0.94909</b>	-0.01123
-1 - -0.5	-0.31701	<b>0.94177</b>	0.01046
decapods	-0.11158	<b>0.93689</b>	-0.09058
-0.5 - 0	-0.33713	<b>0.93382</b>	-0.00584
red algae	-0.27011	<b>0.93031</b>	0.00155
quartzsandstone f.	-0.35817	<b>0.90603</b>	0.05248
0 - 0.5	-0.39621	<b>0.89764</b>	-0.04892
gastropods	0.25585	<b>0.89520</b>	-0.07701
balanids	0.04311	<b>0.83737</b>	-0.15424
0.5 - 1	-0.52819	<b>0.80035</b>	-0.13623
<-1	-0.44783	<b>0.76665</b>	-0.03535
3 - 3.5	-0.57532	<b>0.65504</b>	0.25861
5 - 5.5	0.01183	-0.08216	<b>0.89756</b>
5.5 - 6	0.29708	-0.37703	<b>0.85371</b>
4.5 - 5	-0.26085	-0.13312	<b>0.83200</b>
plant remains	-0.12518	-0.23991	<b>0.82997</b>
6 - 6.5	0.50287	-0.41436	<b>0.74092</b>
4.5 - 4	-0.45928	0.35227	<b>0.63809</b>
agglutinated tubes	0.18562	0.36418	0.41799
bryozoa	0.02530	0.21013	0.40436

Table 6: Rotated factor matrix. In bold letters are components, CaCO<sub>3</sub> and grain size fractions (in  $\phi$ ) being highly loaded with the particular factor.

to a lack of further transport after erosion. This supports the conclusion on the basis of the sedimentological analysis that there is no transport into adjacent facies or along the coast. Component analysis proves that with increasing distance from the Isonzo carbonate rock fragments generally decrease in abundance and that fractions with higher contents of these particles get finer.

Carbonate content is highly positively correlated to carbonate rock fragments and quartz (component group (d)). Both are coming from outside, being mainly supplied by the Isonzo, but also by coastal erosion. A strong negative correlation exists between skeletal components of group (b) (except foraminifera and serpulids), whereas no significant correlations were detected to group (a) components. These results suggest that carbonate content is depending from carbonate rock fragments, autochthonous skeletal grains being unimportant. This interpretation is supported by the fact that carbonate content is lowest where skeletal grains are most abundant and *vice versa*.

The skeletal components of group (b) are highly negatively correlated with terrigenous grains delivered by the Isonzo (carbonate rock fragments, quartz), whereas no significant correlation exists with terrigenous particles supplied by coastal erosion (quartzsandstone fragments). The components originating from coastal erosion are not transported any further once in the marine environment. By contrast, fluvially transported particles are distributed along the whole transect. This suggests that the organisms of group (b) do not avoid the coarse substrate dominated by rock fragments, but the instable ecological conditions related to the Isonzo. These instabilities may have different explanations: on the one hand, an increased seasonal input of clastic particles (bedload) may be unsuitable for long term settlement of benthic organisms; on the other, the varying input of fluvial water changes both salinity and water temperature, both having a negative effect on the organisms.

Finally, component analysis supports the sedimentological result that sedimentation along the transect (except in the sublittoral sand belt) is determined by the fluvial input of the Isonzo.

## 7. Facies

The ultimate objective of this study was an integration of all data (grain size analysis, carbonate content and coarse component (> 250  $\mu$ m) analysis) to define more broadly based facies. To integrate these data, a cluster analysis (Ward's method) was carried out. This led to a differentiation of four groups (clusters) (Fig. 6d) which were defined as four integrated facies (Fig. 19).

Group 1 comprises eleven samples that were also lumped together in Component Facies 2, but which were subdivided by the sedimentological analysis into a sublittoral mud and prodelta facies. The Group 1 facies is dominated by silt-clay and clay-silt with a characteristic grain size spectrum of medium silt to clay. With decreasing distance from the Isonzo the relative content of coarse silt and very coarse silt increases because the clay content decreases. Also typical of this group are the lowest mean grain sizes and carbonate contents, both increasing in the direction of the Isonzo, and poor sorting. Compositionally only bivalves and ophiurids are abundant. However, a large component group, incorporating bivalves, scaphopods, echinoids, ophiurids, holothurian, ostracods, serpulids, parchment-like tubes, all three foraminiferal groups, pellets and mud aggregates can be used to characterize this group. Due to the dominance of autochthonous skeletal particles, especially bivalves and ophiurids, this sample group has been named the **bivalve-ophiurid facies** (Fig. 19).

Sample group 2 includes two samples (AU17, AU18) that were also classified separately in all previous analyses (delta top sedimentary facies, Component Facies 4). The sediments are composed of gravelly sand and sand, with a characteristic content of medium to fine sand, showing large mean grain sizes, best sorting and highest carbonate contents. The only quantitatively important components are carbonate rock fragments, with terrigenous quartz being of minor importance. Due to the almost complete absence of skeletal particles and the dominance of rock fragments a denomination as **terrigenous rock fragment facies** is proposed.

Group 3 is composed of two samples only (AU1, AU2), being previously lumped together in the sublittoral sand facies and in Component Facies 1. The sediments comprise gravelly sands with a high gravel and coarse sand content, largest mean grain sizes, high carbonate contents and poor sorting. Carbonate rock fragments and quartzsandstone fragments are the most abundant components, a large component group (quartzsandstone fragments, gastropods, balanids, decapod crustaceans, red algae, unidentified grains) being diagnostic of this group. Despite the dominance of terrigenous rock fragments, the autochthonous skeletal components are so important that the name **terrigenous biogenic facies** is appropriate.

The three samples of group 4 were previously united in the sedimentary facies of the delta foreset beds and in Component Facies 3. The sediments consist of sandy clay-silts and clayey-sandy silts, characteristically having high contents of very fine sand to coarse silt, small mean grain sizes and low carbonate contents as well as poorest sorting. Carbonate rock fragments and plant remains dominate compositionally, plant remains being the most important. Due to the terrigenous origin of the plants, the name **terrigenous plant facies** (Fig. 19) is considered the proper descriptive term.

To find possible explanations for the distribution of components, grain size and carbonate content a factor analysis (principal component analysis, Varimax rotation) was applied to the whole data set (except the quantitatively unimportant polyplacophors, brachiopods, pteropods, sponge needles, and vertebrate remains). The first 3 factors explain 78.2 % of the variance, the rotated factor matrix being presented in Table 6.

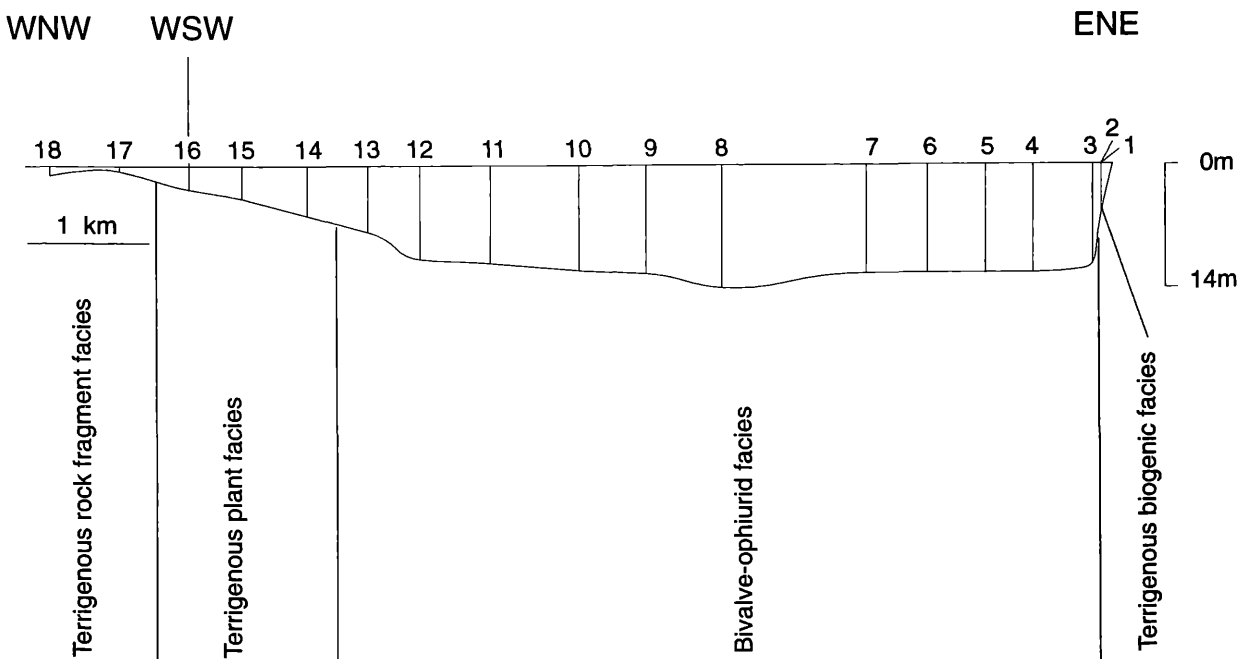

Fig. 19: Facies distribution along the transect.

	AU1	AU2	AU3	AU4	AU5	AU6	AU7	AU8	AU9	AU10	AU11	AU12	AU13	AU14	AU15	AU16	AU17	AU18
total sediment	63.42	63.89	1.72	3.80	2.12	0.32	1.49	3.89	0.15	1.24	0.94	0.73	5.21	6.35	2.62	4.88	78.19	49.41
>63 $\mu\text{m}$	66.69	70.56	41.85	91.57	80.00	50.00	78.42	91.96	40.54	79.49	76.42	76.84	90.14	35.14	16.17	27.84	78.51	50.89

**Table 7:** Percentage proportion of sediment studied (> 250  $\mu\text{m}$ ) in relation to total sediment and to gravel and sand fraction (> 63  $\mu\text{m}$ ).

With factor 1 (50.2 %) bivalves, ophiurids, parchment-like tubes, ostracods, echinoids, and scaphopods as well as fine grain size fractions (> 6.5  $\phi$ ) are highly positively loaded. Highly negatively loaded are carbonate rock fragments and quartz, grain size fractions between 1.5 and 3  $\phi$  and carbonate content.

Both the highly positively loaded components, as well as the fine grain size fractions, are almost exclusively restricted to the sublittoral mud and prodelta sediments of the central bay. The highly negatively loaded components and grain size fractions frequently occur in the delta top sediments, where carbonate content too is high. The sublittoral mud and prodelta areas are characterized by a high, very fine-grained terrigenous suspension load and extremely weak or no current energy. By contrast, at the delta top the coarse clastic sediments are predominantly transported in bedload by strong currents. As a result, substrate conditions are very stable and monotonous in the sublittoral mud and the prodelta, but instable and prove to changes in the delta top. Factor 1 can therefore be interpreted as a **stability factor**.

Factor 2 (16.4 %) is highly positively loaded with unidentified grains, decapod crustaceans, red algae, quartzsandstone fragments, gastropods, balanids, as well as grain size fractions between -1 and 1  $\phi$  and 3.5  $\phi$ . No negative loadings exist.

These components and grain sizes are abundant along the cliff-coast. In the sublittoral sand a high, coarse-grained erosional sediment input occurs but strong currents are absent. This lack of current transport points to a **firm ground factor** for factor 2.

Plant remains and grain size fractions between 4 and 6  $\phi$  are highly positively loaded with factor 3 (explaining 11.7 % of total variance). Besides these sediment fractions plant remains are particularly characteristic of the transitional zone between the central bay and the delta top. The delta foreset beds are formed by a high, fine-grained suspension load, but also by some input from the finest bedload. The plant remains are supplied by the Isonzo, being progressively deposited as current velocity decreases. Factor 3 therefore reflects various transport modes and can thus be interpreted as a **transport factor**.

## 8. Conclusions

1. The Bay of Panzano is a terrigenous environment where autochthonous skeletal sediment production by

benthic organisms is of subordinate importance. The sedimentary characteristics not only result from different sediment sources (fluvial supply vs. cliff-coast erosion) and changing sediment transport mechanisms (bedload vs. suspension load), but also by the variable biogenic content. The latter is due to the fact that the distribution of organisms is both a function of grain size and of the general stability of ecological parameters.

2. Facies can be defined on the basis of sedimentary parameters as well as composition. The results of both approaches are very similar with the exception of the prodelta sediments. The latter reflect a transitional zone between sublittoral mud and delta foreset beds when considering sedimentary parameters. When also taking composition into account, a fusion with the sublittoral mud can be made, both making up the bivalve-ophiurid facies.

3. Of the textural parameters, sorting is of particular interest. It is not only determined by transport-related grain size differentiation but also by "contamination" with autochthonous skeletal particles. Generally, sorting gets poorer when skeletal fragments obscure the transport-induced grain size separation of terrigenous particles. This effect is particularly prominent in the fine-grained prodelta sediments and in the sublittoral mud, where most of the particles > 250  $\mu\text{m}$  are of skeletal origin. An opposite effect occurs in the sublittoral sand, where the clastic products of cliff-coast erosion practically remain in place and their originally poor sorting is further amplified by the addition of autochthonous skeletal fragments. Poor sorting of the delta foreset deposits results from mixing of sediment delivered by bedload with that supplied by suspension transport. Here skeletal particles are of subordinate importance. Best sorting coefficients occur at the delta top, with sediments exclusively transported by bedload containing almost no skeletal particles.

4. The sublittoral sand is genetically totally different from all the other sediments of the bay. It is not related to the fluvial input by the Isonzo, but instead originates from cliff-coast erosion lacking a subsequent transport history. In general, sediment transport in the study area is related to the current energy of the Isonzo river. This supports the opinion of BRAMBATI & VENZO (1967) that sediment distribution in the Gulf of Trieste is exclusively determined by fluvial action and not by marine currents.

5. Control of carbonate content by the contribution of carbonate rock fragments, as postulated by BRAMBATI & VENZO (1967), is supported by the strong correlation of the two parameters. For an ultimate diagnosis it would be necessary to also analyse the finer component fractions.

6. As far as biomass is concerned, the typical epibenthic association of the northern Gulf of Trieste (*Ophiothrix quinque maculata* association) is dominated by sponges, ophiurids, and holothurians (FEDRA, 1978). Although the transect under study traverses the area of this association, the reconstruction of this community is not possible on the basis of the skeletal components >250 µm. Only remains of ophiurids are abundant, whereas sponges and holothurians are unimportant in the sediment record. Nevertheless, the area of this epibenthic association is also clearly separated by the sediment, represented by silt-clays and clay-silts with bivalves and ophiurids as dominating skeletal grains. In conclusion, the *Ophiothrix quinque maculata* association is not preserved as a taphocoenosis. It is, however, reflected sedimentologically as a homogeneous area with characteristic skeletal grains, designated here as bivalve-ophiurid facies.

7. The distribution of skeletal particles is not only dependent on grain size but also on the stability of the ecological parameters of the substrate. This is especially significant in the delta foreset beds which are sedimentologically very uniform. Their content of skeletal grains, however, decreases rapidly with decreasing distance from the Isonzo. As a result, the Isonzo is not only responsible for the distribution of terrigenous sediments in the bay but also for the distribution of organisms and their remains.

8. Evaluating the importance of sedimentary components for the definition of facies, it has to be considered that the studied grain size fraction strongly fluctuates in relation to the total sediment per sample, e.g., 78.19 % in sample AU17 and 0.15 % in sample AU9. Considering only the sediment fraction > 63 µm, the proportion remains below 40 % in only three samples (Table 7). Taking this aspect into account, the component analysis is much more important in the sublittoral sand and at the delta top, where they contribute > 50 % to the sediment, than in the sublittoral mud, prodelta sediments, and delta foreset beds, where they do not even reach 7 %. By contrast, the latter sedimentary facies are dominated by silt and clay, which would be considered as "matrix" in any facies analysis. Nevertheless, expanding the analysis to the components of finer grain sizes could change the component spectrum for some facies, particularly for the bivalve-ophiurid and the terrigenous plant facies.

## 9. Acknowledgements

This study was supported by the "Hochschuljubiläumsstiftung der Stadt Wien". The authors are grateful to the entire staff of the "Laboratorio di Biologia Marina, Aurisina" for their help. Field work was supported by P. Pervesler, J. Hohenegger and C. Baal (Institute of Palaeontology, Univ. Vienna). Thanks are due to J. Nebelsick (Institute of Palaeontology, Univ. Tuebingen), B. Schmid (Natural History Museum Vienna) and I. Zorn (Geological Survey, Vienna) for help with component identification, to E. Libowitzky (Institute of Mineralogy, Univ. Vienna) for EDS-analysis, to H.-G. Krenmayr (Geological Survey, Vienna) for help with the Sedigraph, and to M. Rasser (Institute of Palaeontology, Univ. Vienna) for supporting computer activities. Some figures were drawn by N. Frotzler (Institute of Palaeontology, Univ. Vienna). Special thanks are due to B. Flemming (Wilhelmshaven) for his careful review of the manuscript and correction of the English.

## 10. References

- BRAMBATI, A. & VENZO, G.A., 1967. Recent Sedimentation in the Northern Adriatic Sea between Venice and Trieste. — Studi Trentini di Scienze Naturali. Sez. A., XLIV(2):202–274, 23 Fig., 2 Taf., Trento.
- FAGANELI, J., PEZDIC, J., OGORELEC, B., HERNDL, G.J. & DOLENEC, T., 1991. The role of sedimentary biogeochemistry in the formation of hypoxia in shallow coastal waters (Gulf of Trieste, northern Adriatic). — [in:] TYSON, R.V. & PEARSON, T.H. (eds.), Modern and Ancient Continental Shelf Anoxia. — Geological Society Special Publication, 58:107–117, 4 Fig., London.
- FEDRA, K., 1977. Structural Features of a North Adriatic Benthic Community. — [in:] KEEGAN, B.F., CEIDIGH, P.O. & BOADEN, P.J.S. (eds.), Biology of Benthic Organisms. — :233–246, 3 Fig., Oxford-New York-Toronto-Sydney-Paris-Frankfurt (Pergamon Press).
- FEDRA, K., 1978. On the Ecology of the North Adriatic Sea. Wide-range Investigations on the Benthos: The Gulf of Trieste. — Memorie di Biogeografia Adriatica, IX:69–87, 14 Fig., Venezia.
- FEDRA, K., ÖLSCHER, E.M., SCHERÜBEL, C., STACHOWITSCH, M. & WURZIAN, R.S., 1976. On the Ecology of a North Adriatic Benthic Community: Distribution, Standing Crop and Composition of the Macrobenthos. — Marine Biology, 38:129–145, 9 Fig., Berlin-Heidelberg-New York (Springer-Verlag).
- FOLK, R.L. & WARD, W.C., 1957. Brazos River bar: a study in the significance of grain size parameters. — J. sediment. Petrol., 27(1):3–26, Tulsa, Oklahoma.
- FRIEDMAN, G.M., 1962. On sorting, sorting coefficients, and the lognormality of the grain-size distribution of sandstones. — Journal Geology, 70(6):737–753, Chicago, Illinois.
- FÜTTERER, D.K., 1974. Significance of the boring sponge *Cliona* for the origin of fine grained material of carbo-

- nate sediments. — *J. sediment. Petrol.*, **44**:79–84, 3 Fig., Tulsa, Oklahoma.
- HOHENEGGER, J. & PERVESLER, P., 1985. Orientation of crustacean burrows. — *Lethaia*, **18**:323–339, 11 Fig., Oslo.
- HOHENEGGER, J., PILLER, W. & BAAL, C., 1989. Reasons for Spatial Microdistributions of Foraminifers in an Intertidal Pool (Northern Adriatic Sea). — *Marine Ecology* **10** (1):43–78, 19 Fig., Berlin-Hamburg.
- HOHENEGGER, J., PILLER, W.E. & BAAL, C., 1993. Horizontal and Vertical Spatial Microdistribution of Foraminifers in the Shallow Subtidal Gulf of Trieste, Northern Adriatic Sea. — *J. Foraminiferal Res.* **23**:79–101, 7 Fig., 1 Pl., Lawrence.
- JUSTIC, D., 1991. Hypoxic conditions in the northern Adriatic Sea: historical development and ecological significance. — [in:] TYSON, R.V. & PEARSON, T.H. (eds.). *Modern and Ancient Continental Shelf Anoxia*. — Geological Society Special Publication, **58**:95–105, 9 Fig., London.
- KLEEMANN, K.H., 1973. Der Gesteinsabbau durch Ätzmuscheln an Kalkküsten. — *Oecologia*, **13**:377–395, 9 Fig., Berlin.
- MALECKI, G., 1986. SEDPAK - Charakterisierung von Sedimenten aufgrund der Korngrößenanalyse. — *Ber. Geol. Bundesanst.* **1**, Blg. 12, Wien.
- MORELLI, C. & MOSETTI, F., 1968. Rilievo seismico continuo nel Golfo di Trieste. — *Bollettino della Società Adriatica di Scienze*, **LVI**(1):42–57, 5 Fig., Trieste.
- MOSETTI, F., 1967. Caratteristiche idrologiche dell'Adriatico settentrionale. — *Atti dell'Istituto Veneto di Scienze, Lettere ed Arti / Classe di scienze matematiche e naturali*, **CXXV**:147–165, 5 Fig., Venezia.
- MÜLLER, G. & GASTNER, M., 1971. The "Karbonat-Bombe", a simple device for the determination of the carbonate content in sediments, soils and other materials. — *N. Jb. Miner. Mh.*, **1971**, H. 10:466–469, 1 Fig., Stuttgart.
- OGORELEC, B., MISIC, M. & FAGANELI, J., 1991. Marine geology of the Gulf of Trieste (northern Adriatic): Sedimentological aspects. — *Marine Geology*, **99**:79–92, 10 Fig., Amsterdam (Elsevier).
- ÖLSCHER, E.M. & FEDRA, K., 1977. On the Ecology of a Suspension Feeding Benthic Community: Filter Efficiency and Behaviour. — [in:] KEEGAN, B.F., CEIDIGH, P.O. & BOADEN, P.J.S. (eds.): *Biology of Benthic Organisms*. — :483–492, 3 Fig., Oxford-New York-Toronto-Sydney-Paris-Frankfurt (Pergamon Press).
- PERVESLER, P., 1985. Zum Vergleich fossiler und rezenter Crustaceenbauten. — Unveröff. Diss. Univ. Wien, 123 pp., 48 Fig., Wien.
- PERVESLER, P. & DWORSCHAK, P.C., 1985. Burrows of *Jaxea nocturna* NARDO in the Gulf of Trieste. — *Senckenbergiana maritima* **17**:33–53, 3 Fig., 4 Pl., Frankfurt/Main.
- ROSCHAL, J.H., 1991. Räumliche Verteilung und jahreszeitliche Veränderungen der Foraminiferenfaunen in der Bucht von Panzano (nördliche Adria, Italien). — Unveröff. Diss. Univ. Wien, 160 pp., 96 Fig., 5 Taf., Wien.
- SARNTHEIN, M., 1971. Oberflächensedimente im Persischen Golf und Golf von Oman. II. Quantitative Komponentenanalyse der Grobfraktion. — „Meteor“ Forschungsergebnisse, Reihe C, **5**:1–113, 45 Fig., 4 Taf., Berlin-Stuttgart (Gebrüder Bornträger).
- SCHUBÖ, W. & UEHLINGER, H.-M., 1986. SPSS\*: Handbuch der Programmversion 2.2. — XIV+659 pp., Stuttgart-New York (G. Fischer).
- STACHOWITSCH, M., 1977. The Hermit Crab Microbiocoenosis - The Role of Mobile Secondary Hardbottom Elements in a North Adriatic Benthic Community. — [in:] KEEGAN, B.F., CEIDIGH, P.O. & BOADEN, P.J.S. (eds.): *Biology of Benthic Organisms*. — :549–558, 1 Fig., Oxford-New York-Toronto-Sydney-Paris-Frankfurt (Pergamon Press).
- STACHOWITSCH, M., 1984. Mass Mortality in the Gulf of Trieste: The Course of Community Destruction. — *P.S.Z.N.I: Marine Ecology*, **5**(3):243–264, 20 Fig., Berlin - Hamburg.
- STACHOWITSCH, M., 1986. The Gulf of Trieste: a sensitive ecosystem. — *Nova Thalassia*, **8**(3):221–235, 3 Fig., Triest.
- STACHOWITSCH, M., 1991. Anoxia in the Northern Adriatic Sea: Rapid death, slow recovery. — [in:] TYSON, R.V. & PEARSON, T.H. (eds.). *Modern and Ancient Continental Shelf Anoxia*. — Geological Society Special Publication, **58**:119–129, 4 Fig., London.
- VAN STRAATEN, L.M.J.U., 1970. Holocene and late-Pleistocene sedimentation in the Adriatic Sea. — *Geologische Rundschau*, **60**:106–131, 10 Fig., Stuttgart.
- STEFANINI, S., 1968. Distribuzione dei carbonati di calcio e di magnesio nelle sabbie dei fiumi tributari dell'Adriatico settentrionale tra Venezia e Trieste e dei loro principali affluenti. — *Studi Trentini di Scienze Naturali. Sez. A.*, **XLV**(2):118–140, 4 Fig., Trento.
- TORUNSKI, H., 1979. Biological Erosion and its Significance for the Morphogenesis of Limestone Coasts and for Nearshore Sedimentation (Northern Adriatic). — *Senckenbergiana maritima*, **11**(3/6):193–265, 31 Fig., 4 Taf., Frankfurt a. M.
- VENZO, G. A. & STEFANINI, S., 1967. Distribuzione dei carbonati nei sedimenti di spiaggia e marini dell'Adriatico settentrionale fra Venezia e Trieste. — *Studi Trentini di Scienze Naturali. Sez. A.*, **XLIV**(2):178–201, 9 Fig., Trento.

sample number: AU 1				water depth: 6 m													sediment terminology: gravelly sand													carbonate content: 62%													
sediment weight (g)	weight % (>250µm)	splits	counted grains	calculated grain no.	grain size in mm	carbonate rock f.	quartzsandstone f.	quartz	gastropods	bivalves	polyplacophors	scaphopods	pteropods	echinoids	ophiurids	holothurans	balanids	decapods	ostracods	bryozoa	brachiopods	serpulids	parchment-like tubes	agglutinated tubes	hyaline forams	milloid forams	agglutinated forams	red algae	sponge spicules	plant remains	vertebrates	pellets	tar clumps	unidentified									
20.54	32.15	0	638	638	>2	46.24	16.77	0.00	18.50	9.56	0.00	0.00	0.00	0.00	0.00	0.00	1.10	1.72	0.00	0.00	0.00	2.66	0.00	0.16	0.00	0.00	0.00	0.16	0.00	0.00	0.00	0.00	0.00	0.00	0.16	2.98							
6.05	9.47	0	1182	1182	2-1.4	41.62	16.67	0.00	20.56	10.49	0.17	0.00	0.00	1.02	0.00	0.00	1.02	2.37	0.00	0.08	0.00	2.20	0.00	0.93	0.00	0.00	0.00	0.85	0.00	0.17	0.00	0.00	0.00	0.17	1.69								
7.05	11.03	1	1984	3968	1.4-1	36.90	13.26	0.05	17.44	13.16	0.05	0.00	0.00	0.86	0.10	0.00	2.52	2.87	0.00	0.05	0.05	1.86	0.05	0.45	0.15	0.10	0.00	1.86	0.00	0.00	0.00	0.00	0.00	0.66	7.56								
7.37	11.54	4	640	10240	1-0.71	35.78	13.13	0.00	19.22	11.88	0.00	0.00	0.00	1.09	0.00	0.00	2.81	2.34	0.00	0.16	0.00	1.56	0.47	0.00	2.19	0.31	0.00	5.31	0.00	0.31	0.00	0.31	0.16	2.97									
8.16	12.77	6	399	25536	.71-.50	32.08	9.02	0.00	14.29	15.04	0.00	0.00	0.00	1.00	0.00	0.00	1.25	2.76	0.00	0.25	0.00	1.75	0.00	1.50	3.51	1.00	0.25	8.52	0.00	0.25	0.00	2.01	2.26	3.26									
6.18	9.67	7	508	65024	.50-.355	41.14	15.16	2.95	9.06	10.43	0.00	0.00	0.00	0.79	0.20	0.00	0.79	0.20	0.00	0.00	0.00	0.20	0.00	0.00	1.97	2.36	0.20	5.12	0.00	0.39	0.00	0.98	2.36	5.71									
8.54	13.37	8	798	204288	.355-.250	42.36	17.04	7.39	4.14	8.15	0.00	0.00	0.00	0.13	0.13	0.00	0.25	0.50	0.25	0.63	0.00	0.38	0.25	0.38	0.88	0.63	0.00	3.38	0.13	0.00	0.00	7.89	2.01	3.13									
total frequency (%)																																											
sample number: AU 2				water depth: 7 m													sediment terminology: gravelly sand													carbonate content: 57%													
40.98	15.81	5.48	6.76	9.39	0.00	0.00	0.00	0.00	0.38	0.12	0.00	0.56	0.72	0.16	0.44	0.00	0.52	0.18	0.38	1.35	1.00	0.06	4.20	0.08	0.11	0.00	0.57	2.01	3.73														

Appendix 1: Data (%) of component analysis.



sample number: AU 3				water depth: 11.5 m	sediment terminology: clay-silt																carbonate content: 26%													
sediment weight (g)	weight % (>250µm)	counted grains	calculated grain no.	grain size (mm)	carbonate rock f.	quartzsandstone f.	quartz	gastropods	bivalves	polyplacophors	scaphopods	pteropods	echinoids	ophiurids	holothurians	balanids	decapods	ostracods	bryozoa	brachiopods	serpulids	parchment-like tubes	hyaline forams	millolid forams	agglutinated forams	red algae	sponge spicules	plant remains	vertebrates	pellets	tar clumps	unidentified		
0.87	50.58	0	90	>2	0.00	0.00	1.11	17.78	43.33	0.00	3.33	0.00	20.00	0.00	0.00	4.44	0.00	0.00	0.00	0.00	0.00	3.33	0.00	3.33	0.00	0.00	0.00	0.00	0.00	0.00	0.00	0.00	0.00	0.00
0.21	12.21	0	115	2-1.4	0.00	0.00	0.00	12.17	36.52	0.00	2.61	0.00	27.83	0.00	0.00	2.61	0.00	0.00	0.00	0.00	0.00	6.09	2.61	0.00	0.00	0.00	0.00	0.00	0.00	0.00	0.00	0.00	0.00	0.00
0.16	9.30	0	228	1.4-1	0.88	0.00	0.88	6.14	44.74	0.00	1.75	0.00	19.74	0.44	0.00	0.88	0.00	0.00	0.00	0.00	0.00	1.75	14.04	0.00	0.00	0.00	0.00	0.00	0.00	0.00	0.00	0.00	0.00	0.00
0.09	5.23	0	307	1-0.71	0.00	0.00	0.00	7.17	38.44	0.00	3.91	0.00	15.31	3.58	0.00	1.63	0.00	0.00	0.00	0.00	0.00	0.65	14.66	0.00	3.26	0.33	0.00	0.00	0.00	0.33	0.00	0.00	0.00	0.00
0.15	8.72	0	1134	.71-.50	0.44	0.00	0.18	5.82	43.74	0.00	1.85	0.00	10.41	5.03	0.00	0.26	0.00	0.18	0.00	0.00	0.00	1.68	12.17	0.00	3.09	0.88	0.00	0.00	0.00	0.00	0.00	0.00	0.00	0.00
0.14	8.14	2	535	.50-.355	0.99	0.00	0.00	2.06	31.03	0.00	0.00	0.00	12.52	9.91	0.00	0.19	0.00	0.56	0.00	0.00	0.00	1.31	27.48	0.37	3.95	2.06	0.00	0.00	0.00	0.00	0.00	0.00	0.00	0.00
0.10	5.81	3	769	.355-.250	2.73	0.00	0.13	31.99	0.00	0.65	0.00	7.54	16.64	0.00	0.39	0.00	0.39	0.00	0.00	0.00	0.00	0.13	18.08	0.00	7.28	4.16	0.52	0.00	0.00	4.55	0.00	1.17	2.34	
total frequency (%)					1.93	0.00	0.13	2.28	33.73	0.00	0.82	0.00	9.76	12.84	0.00	0.44	0.00	0.37	0.00	0.00	0.00	0.70	18.90	0.08	5.56	3.06	0.31	0.00	0.04	2.86	0.00	3.71	2.01	
sample number: AU 4					sediment terminology: silt-clay																carbonate content: 26%													
3.46	91.05	0	44	>2	0.00	0.00	0.00	2.27	95.45	0.00	2.27	0.00	0.00	0.00	0.00	0.00	0.00	0.00	0.00	0.00	0.00	0.00	0.00	0.00	0.00	0.00	0.00	0.00	0.00	0.00	0.00	0.00	0.00	
0.04	1.05	0	33	2-1.4	0.00	0.00	0.00	3.03	48.48	0.00	0.00	0.00	3.03	0.00	0.00	3.03	0.00	0.00	0.00	0.00	0.00	6.06	21.21	0.00	0.00	0.00	0.00	0.00	0.00	0.00	0.00	0.00	0.00	0.00
0.08	2.11	0	106	1.4-1	0.94	0.00	0.00	5.66	39.62	0.00	9.43	0.00	3.77	3.77	0.00	2.83	0.00	0.00	0.00	0.00	0.00	5.66	7.55	0.00	0.00	0.00	0.00	0.00	0.00	0.00	0.00	0.00	0.00	0.00
0.05	1.32	0	157	1-0.71	0.00	0.00	1.27	3.82	57.32	0.00	5.10	0.00	6.37	1.91	0.00	0.00	0.64	0.00	0.00	0.00	0.00	1.91	7.84	0.00	0.64	0.00	0.00	0.00	0.00	0.00	0.00	0.00	0.00	0.00
0.06	1.58	0	452	.71-.50	0.88	0.00	0.66	4.20	51.11	0.00	3.98	0.00	1.99	9.29	0.00	0.66	0.00	0.00	0.00	0.00	0.00	3.32	9.51	0.22	0.44	0.00	0.00	0.00	0.00	0.00	0.00	0.00	0.00	0.00
0.05	1.32	0	948	.50-.355	2.00	0.00	0.11	2.00	48.21	0.00	2.00	0.00	7.81	10.65	0.00	0.21	0.00	0.84	0.00	0.00	0.00	1.27	6.96	0.11	0.63	0.53	0.00	0.00	0.42	0.00	0.00	0.00	0.00	0.00
0.06	1.58	2	785	.355-.250	3.82	0.00	0.25	1.27	38.47	0.00	1.91	0.00	6.75	17.20	0.13	0.13	0.25	0.89	0.00	0.00	0.00	0.64	9.94	0.51	0.76	0.51	1.66	0.00	0.00	0.76	0.00	0.00	0.00	0.00
total frequency (%)					2.95	0.00	0.29	1.89	42.75	0.00	2.38	0.00	6.95	14.14	0.08	0.27	0.18	0.74	0.00	0.00	0.00	1.19	9.18	0.37	0.66	0.47	1.17	0.00	0.00	0.59	0.00	0.00	0.00	

Appendix 1 (continued): Data (%) of component analysis.

sample number: AU 5			water depth: 12.5 m	sediment terminology: clay-silt																carbonate content: 26%											
1.58	74.53	0	50	>2	0.00	0.00	0.00	14.00	48.00	0.00	6.00	0.00	0.00	0.00	0.00	2.00	0.00	0.00	14.00	2.00	0.00	0.00	0.00	0.00	0.00	0.00	6.00	2.00	6.00		
0.09	4.25	0	44	2-1.4	0.00	0.00	0.00	15.91	40.91	0.00	6.82	0.00	6.82	4.55	0.00	6.82	0.00	0.00	18.18	0.00	0.00	0.00	0.00	0.00	0.00	0.00	0.00	0.00	0.00		
0.09	4.25	0	94	1.4-1	0.00	0.00	2.13	15.96	45.74	0.00	3.19	0.00	9.57	0.00	8.51	0.00	8.51	0.00	8.51	6.38	0.00	0.00	0.00	0.00	0.00	0.00	0.00	0.00	0.00		
0.06	3.77	0	275	1-0.71	0.00	0.00	0.36	2.91	47.64	0.00	2.91	0.00	14.18	1.82	0.00	2.55	0.00	0.00	7.27	13.82	0.36	0.00	0.00	0.00	0.00	0.00	0.36	0.00	5.09	0.00	
0.09	4.25	0	650	.71-.50	1.54	0.00	0.00	3.54	52.31	0.00	2.62	0.00	16.82	6.46	0.00	1.54	0.00	0.00	2.00	6.00	0.00	0.77	0.00	0.00	0.00	0.00	0.00	4.77	0.77	1.08	
0.08	3.77	1	694	.50-.355	5.04	0.00	0.29	2.02	41.50	0.00	0.43	0.00	8.07	26.08	0.00	0.72	0.58	0.00	1.87	3.46	0.14	1.30	1.73	1.30	0.00	0.00	0.86	0.14	1.73	1.01	1.73
0.11	5.19	3	602	.355-.250	8.80	0.00	0.50	1.50	35.38	0.00	0.66	0.00	9.14	25.75	0.66	0.00	0.83	0.00	1.99	5.32	0.00	2.66	1.33	0.66	0.00	0.00	1.16	0.00	1.66	1.33	0.66
total frequency (%)					6.89	0.00	0.42	2.19	38.76	0.00	0.98	0.00	9.72	22.56	0.44	0.40	0.14	0.66	0.00	2.43	5.30	0.04	2.06	1.20	0.68	0.00	0.94	0.03	2.08	1.15	0.93
sample number: AU 6			water depth: 12.5 m	sediment terminology: silt-clay																carbonate content: 26%											
0.10	31.25	0	23	>2	0.00	0.00	0.00	30.43	0.00	4.35	0.00	4.35	0.00	0.00	0.00	0.00	0.00	0.00	60.87	0.00	0.00	0.00	0.00	0.00	0.00	0.00	0.00	0.00	0.00	0.00	0.00
0.03	9.98	0	15	2-1.4	0.00	0.00	0.00	13.33	53.33	0.00	6.67	0.00	13.33	0.00	0.00	0.00	0.00	0.00	13.33	0.00	0.00	0.00	0.00	0.00	0.00	0.00	0.00	0.00	0.00	0.00	0.00
0.03	9.98	0	121	1.4-1	0.83	0.00	0.00	4.96	33.06	0.00	1.65	0.00	13.22	0.00	1.65	0.00	0.00	0.00	1.65	9.92	0.00	0.83	0.00	0.00	0.00	0.83	0.00	22.31	0.00	0.00	
0.04	12.50	0	162	1-0.71	1.23	0.00	0.00	3.09	29.63	0.00	2.47	0.00	13.58	8.02	0.00	0.62	0.00	1.23	12.35	0.62	0.62	0.00	0.00	0.00	0.00	0.00	0.00	24.69	0.62	0.00	
0.02	6.25	0	253	.71-.50	2.37	0.00	0.00	1.58	35.97	0.00	2.37	0.00	9.09	13.44	0.00	0.00	0.40	0.00	1.58	13.83	1.98	1.58	0.00	0.00	0.00	0.00	14.23	0.40	1.19	0.40	
0.04	12.50	0	915	.50-.355	2.51	0.00	0.11	1.20	31.26	0.00	0.22	0.00	10.16	27.32	0.00	0.11	1.42	0.00	0.55	11.15	0.33	0.22	0.66	0.11	0.00	0.87	0.00	11.15	0.00	0.55	
0.06	18.75	2	1008	.355-.250	4.66	0.00	0.69	0.69	27.38	0.00	0.30	0.00	10.02	32.74	0.60	0.00	0.69	0.00	0.00	6.35	0.79	1.69	0.69	0.50	0.00	0.30	2.68	0.00	8.73	0.10	0.40
total frequency (%)					3.99	0.00	0.53	1.01	26.69	0.00	0.51	0.00	10.02	29.63	0.43	0.07	0.02	0.60	0.00	0.24	7.99	0.74	1.36	0.63	0.38	0.00	2.12	0.00	10.09	0.11	0.43

Appendix 1 (continued): Data (%) of component analysis.

sample number: AU 7				water depth: 12.5 m																	sediment terminology: silt-clay										carbonate content: 26%									
sediment weight (g)	weight % (>250µm)	counted grains	calculated grain no.	grain size (mm)	carbonate rock f.	quartzsandstone f.	quartz	gastropods	bivalves	polyplacophors	scaphopods	pteropods	echinoids	ophiurids	holothurians	balanids	decapods	ostracods	byzoa	brachiopods	serpulids	parchment-like tubes	agglutinated tubes	hyaline forams	milloid forams	agglutinated forams	red algae	sponge spicules	plant remains	vertebrates	pellets	tar clumps	unidentified							
3.41	87.66	0	47	>2	0.00	0.00	23.40	63.83	0.00	2.13	0.00	2.13	0.00	2.13	0.00	2.13	0.00	2.13	0.00	0.00	2.13	4.26	0.00	0.00	0.00	0.00	0.00	0.00	0.00	0.00	0.00	0.00	0.00	0.00	0.00					
0.09	2.31	0	40	2-1.4	0.00	0.00	15.00	32.50	0.00	7.50	0.00	0.00	0.00	0.00	0.00	0.00	0.00	0.00	0.00	0.00	2.50	7.50	0.00	0.00	0.00	0.00	0.00	0.00	0.00	0.00	0.00	0.00	0.00	0.00	2.50					
0.07	1.80	0	93	1.4-1	0.00	0.00	20.43	37.63	0.00	3.23	0.00	10.75	3.23	0.00	1.08	0.00	0.00	0.00	0.00	0.00	4.30	11.83	0.00	0.00	0.00	0.00	0.00	0.00	0.00	0.00	0.00	0.00	0.00	0.00	0.00	0.00				
0.07	1.80	0	228	1-0.71	0.88	0.00	7.89	37.72	0.00	1.75	0.00	3.51	9.21	0.00	0.44	0.00	0.44	0.00	0.00	0.00	3.07	19.30	0.44	0.00	0.00	0.00	0.00	0.00	0.00	0.00	0.00	0.00	0.00	0.00	0.00	2.63				
0.08	2.06	0	639	.71-.50	0.78	0.00	3.76	37.40	0.00	1.56	0.00	9.86	13.30	0.00	0.16	0.00	0.16	0.00	0.00	0.00	2.97	14.87	0.00	1.10	0.63	0.00	0.00	0.00	0.00	0.00	0.00	0.00	0.00	0.00	0.00	0.00	0.00			
0.07	1.80	1	1398	.50-.355	3.43	0.00	0.14	3.72	30.04	0.00	0.86	0.00	6.15	35.48	0.00	0.00	0.14	0.72	0.00	0.00	0.72	10.01	0.14	0.57	0.57	0.29	0.00	0.00	0.00	0.00	0.00	0.00	0.00	0.00	0.00	1.00				
0.10	2.57	3	563	.355-.250	8.53	0.00	1.95	27.89	0.00	0.00	0.00	4.97	33.75	1.42	0.00	0.18	2.13	0.00	0.00	0.00	0.00	4.80	0.36	3.02	1.78	0.71	0.00	0.18	0.53	0.00	0.00	0.00	0.00	0.00	0.00	0.00	0.00			
total frequency %					6.32	0.00	0.03	3.14	29.92	0.00	0.47	0.00	5.76	30.58	0.92	0.06	0.14	1.54	0.00	0.00	0.60	7.35	0.27	2.17	1.32	0.52	0.00	0.12	0.37	0.00	0.00	0.00	0.00	0.00	0.00	0.53				
total frequency %					sediment terminology: silt-clay																	carbonate content: 29%																		
sample number: AU 8				water depth: 14 m																																				

Appendix 1 (continued): Data (%) of component analysis.

sample number: AU 9				water depth: 13 m																sediment terminology: clay-silt																carbonate content: 31%																	
sediment weight (g)	weight % (>250µm)	splits	counted grains	calculated grain no.	grain size (mm)	carbonate rock f.	quartzsandstone f.	quartz	gastropods	bivalves	polyplacophors	scaphopods	pteropods	echinoids	ophiurids	holothurians	balanids	decapods	ostracods	bryozoa	brachiopods	serpulids	parchment-like tubes	agglutinated tubes	hyaline forams	mollid forams	agglutinated forams	red algae	sponge spicules	plant remains	vertebrates	pellets	tar clumps	unidentified																			
0.02	13.33	0	2	2	>2	0.00	0.00	50.00	0.00	0.00	0.00	0.00	0.00	0.00	0.00	0.00	0.00	0.00	0.00	0.00	0.00	0.00	0.00	0.00	0.00	0.00	0.00	0.00	0.00	0.00	0.00	0.00	0.00	0.00	0.00																		
0.01	6.67	0	6	6	2-1.4	0.00	0.00	50.00	0.00	0.00	0.00	0.00	0.00	0.00	0.00	0.00	0.00	0.00	0.00	0.00	0.00	0.00	33.33	16.67	0.00	0.00	0.00	0.00	0.00	0.00	0.00	0.00	0.00	0.00	0.00	0.00																	
0.01	6.67	0	24	24	1.4-1	0.00	0.00	54.17	0.00	0.00	0.00	0.00	0.00	0.00	0.00	0.00	0.00	0.00	0.00	0.00	0.00	0.00	45.83	0.00	0.00	0.00	0.00	0.00	0.00	0.00	0.00	0.00	0.00	0.00	0.00	0.00																	
0.01	6.67	0	63	63	1-0.71	0.00	0.00	46.03	0.00	0.00	3.17	4.76	0.00	0.00	0.00	0.00	0.00	0.00	0.00	0.00	0.00	6.35	33.33	0.00	0.00	0.00	0.00	0.00	0.00	0.00	0.00	0.00	0.00	0.00	0.00	0.00	1.59																
0.03	20.00	0	235	235	.71-.50	1.28	0.00	5.96	38.72	0.00	2.13	0.00	8.51	13.19	0.00	0.43	0.43	0.00	0.43	0.00	0.00	5.96	16.17	0.00	0.43	0.00	0.00	0.00	0.00	0.00	0.00	0.00	0.43	3.83	2.13	0.43																	
0.03	20.00	0	691	691	.50-.355	2.17	0.00	0.43	2.60	35.02	0.00	1.01	0.00	5.79	26.92	0.00	0.43	0.14	1.01	0.00	0.00	4.34	7.96	0.14	0.43	1.45	1.16	0.00	0.00	0.00	0.00	0.00	0.00	5.35	2.32	1.30																	
0.04	26.67	2	649	2596	.355-.250	5.86	0.00	2.62	34.21	0.00	0.77	0.00	4.93	29.74	0.46	0.15	0.00	1.69	0.00	0.00	1.69	6.63	0.31	1.69	1.39	2.00	0.00	0.00	0.00	0.00	0.00	0.00	1.69	1.23	0.92																		
total frequency (%)						4.70	0.00	1.52	2.93	34.94	0.00	0.89	0.00	5.26	27.44	0.33	0.19	0.06	1.44	0.00	0.00	2.60	8.24	0.25	1.33	1.27	1.66	0.00	0.00	0.00	0.00	0.00	2.49	1.47	0.97																		
sample number: AU 10						water depth: 12 m																sediment terminology: clay-silt																carbonate content: 31%															
sediment weight (g)	weight % (>250µm)	splits	counted grains	calculated grain no.	grain size (mm)	carbonate rock f.	quartzsandstone f.	quartz	gastropods	bivalves	polyplacophors	scaphopods	pteropods	echinoids	ophiurids	holothurians	balanids	decapods	ostracods	bryozoa	brachiopods	serpulids	parchment-like tubes	agglutinated tubes	hyaline forams	mollid forams	agglutinated forams	red algae	sponge spicules	plant remains	vertebrates	pellets	tar clumps	unidentified																			
0.80	64.52	0	27	27	>2	0.00	0.00	14.81	55.56	0.00	3.70	0.00	0.00	0.00	0.00	0.00	0.00	0.00	0.00	0.00	0.00	14.81	7.41	0.00	0.00	0.00	0.00	0.00	0.00	0.00	0.00	0.00	0.00	0.00	0.00	3.70																	
0.09	7.26	0	39	39	2-1.4	0.00	0.00	15.38	56.41	0.00	0.00	0.00	10.26	2.56	0.00	0.00	0.00	0.00	0.00	0.00	0.00	7.69	7.69	0.00	0.00	0.00	0.00	0.00	0.00	0.00	0.00	0.00	0.00	0.00	0.00	0.00																	
0.06	4.84	0	68	68	1.4-1	0.00	0.00	16.18	44.12	0.00	4.41	0.00	10.29	4.41	0.00	1.47	0.00	0.00	0.00	0.00	0.00	4.41	11.76	1.47	0.00	0.00	0.00	0.00	0.00	0.00	0.00	0.00	0.00	0.00	0.00	0.00																	
0.04	3.23	0	172	172	1-0.71	0.58	0.00	8.14	56.98	0.00	1.74	0.00	2.33	8.14	0.00	0.58	1.16	0.00	0.00	0.00	0.00	2.91	13.37	0.00	0.58	0.00	0.00	0.00	0.00	0.00	0.00	0.00	0.00	0.00	0.00	2.91																	
0.07	5.65	0	487	487	.71-.50	1.23	0.00	8.01	39.43	0.00	2.05	0.00	3.90	25.87	0.00	0.21	0.00	0.00	0.00	0.00	0.00	4.31	10.68	0.00	0.41	0.62	0.00	0.00	0.00	0.00	0.00	0.00	2.87	0.00	0.41																		
0.08	6.45	1	800	1600	.50-.355	4.25	0.00	0.25	1.75	28.13	0.00	0.75	0.00	2.38	41.88	0.00	0.25	0.13	1.13	0.00	0.00	1.13	8.75	0.13	0.50	1.63	1.38	0.00	0.13	0.00	0.13	4.75	0.25	0.38																			
0.10	8.06	3	469	3752	.355-.250	11.73	0.00	1.07	3.20	26.01	0.00	0.21	0.00	3.20	33.69	0.21	0.21	0.00	1.49	0.00	0.00	0.00	5.33	0.43	1.49	2.99	2.13	0.00	0.21	0.85	0.00	3.20	1.71	0.64																			
total frequency (%)						8.38	0.00	0.72	3.61	29.02	0.00	0.60	0.00	3.12	33.82	0.13	0.24	0.07	1.20	0.00	0.00	0.00	0.88	6.97	0.31	1.09	2.29	1.66	0.00	0.16	0.55	0.03	3.42	1.11	0.62																		

Appendix 1 (continued): Data (%) of component analysis.

sample number: AU 11			water depth: 11.5 m														sediment terminology: clay-silt										carbonate content: 34.5%									
			water depth: 11.5 m														sediment terminology: clay-silt										carbonate content: 34.5%									
0.45	47.87	0	15	15	>2	0.00	0.00	0.00	6.67	80.00	0.00	0.00	0.00	0.00	0.00	0.00	0.00	0.00	0.00	6.67	6.67	0.00	0.00	0.00	0.00	0.00	0.00	0.00	0.00	0.00	0.00	0.00	0.00	0.00	0.00	
0.04	4.26	0	27	27	2-1.4	0.00	0.00	0.00	11.11	48.15	0.00	0.00	0.00	0.00	0.00	0.00	0.00	0.00	0.00	0.00	40.74	0.00	0.00	0.00	0.00	0.00	0.00	0.00	0.00	0.00	0.00	0.00	0.00	0.00	0.00	
0.03	3.19	0	48	48	1.4-1	0.00	0.00	0.00	10.42	52.08	0.00	0.00	2.08	0.00	0.00	0.00	0.00	0.00	0.00	0.00	18.75	0.00	0.00	0.00	0.00	0.00	0.00	0.00	0.00	0.00	0.00	0.00	0.00	0.00	2.08	0.00
0.03	3.19	0	133	133	1-0.71	0.00	0.00	0.00	3.76	45.11	0.00	2.26	0.00	0.75	23.31	0.00	0.00	0.00	0.00	0.00	16.54	0.00	0.00	0.00	0.00	0.00	0.00	0.00	0.00	0.00	0.00	0.00	0.00	3.01	0.00	
0.08	8.51	0	716	716	.71-.50	2.37	0.00	0.70	1.82	24.86	0.00	0.84	0.00	2.65	47.21	0.00	0.14	0.00	0.00	2.85	11.73	0.28	0.56	0.00	0.00	0.00	0.00	0.00	0.00	0.00	0.00	0.56	0.00	2.93	0.14	
0.14	14.89	2	503	2012	.50-.355	8.35	0.00	0.20	1.39	20.87	0.00	0.60	0.00	1.99	50.30	0.00	0.20	0.00	0.60	0.40	8.75	0.20	1.79	0.99	1.39	0.00	0.00	0.00	0.00	0.00	0.00	0.00	1.19	0.40		
0.17	18.09	4	486	7776	.355-.250	13.58	0.00	0.21	0.62	20.58	0.00	0.41	0.21	1.44	47.53	0.21	0.00	1.23	0.00	0.21	6.38	0.00	0.62	2.26	2.06	0.00	0.00	0.00	0.00	0.00	1.85	0.00	0.62			
			total frequency (%)			11.57	0.00	0.24	0.96	21.52	0.00	0.49	0.15	1.61	47.35	0.15	0.06	0.00	1.02	0.00	0.48	7.45	0.06	0.82	1.86	1.75	0.00	0.00	0.04	0.00	1.81	0.08	0.53			
sediment weight (g)	weight % (>250µm)	spills	counted grains	calculated grain no.	grain size (mm)	carbonate rock f.	quartzsandstone f.	quartz	gastropods	bivalves	polyplacophors	scaphopods	pteropods	echinoids	ophiurans	holothurians	balanids	decapods	ostracods	bryozoa	brachiopods	serpulids	parchment-like tubes	agglutinated tubes	hyaline forams	miliolid forams	agglutinated forams	red algae	sponge spicules	plant remains	vertebrates	pellets	tar clumps	unidentified		
0.39	53.42	0	14	14	>2	0.00	0.00	14.29	42.86	0.00	0.00	0.00	0.00	0.00	0.00	7.14	0.00	0.00	0.00	0.00	0.00	28.57	7.14	0.00	0.00	0.00	0.00	0.00	0.00	0.00	0.00	0.00	0.00	0.00		
0.03	4.11	0	25	25	2-1.4	0.00	0.00	4.00	68.00	0.00	0.00	0.00	0.00	0.00	0.00	0.00	0.00	0.00	0.00	0.00	0.00	16.00	12.00	0.00	0.00	0.00	0.00	0.00	0.00	0.00	0.00	0.00	0.00	0.00		
0.03	4.11	0	66	66	1.4-1	0.00	0.00	12.12	48.48	0.00	0.00	0.00	0.00	3.03	7.58	0.00	0.00	0.00	0.00	0.00	0.00	0.00	27.27	0.00	0.00	0.00	0.00	0.00	0.00	0.00	0.00	1.52	0.00	0.00		
0.05	6.85	0	184	184	1-0.71	0.00	0.00	8.70	40.22	0.00	1.63	0.00	0.00	0.00	9.24	0.00	0.00	0.00	0.00	0.00	0.00	6.52	23.37	0.00	1.63	0.00	0.00	0.00	0.00	0.00	0.00	5.43	0.00	3.26	0.00	
0.07	9.59	0	532	532	.71-.50	0.00	0.00	5.83	41.17	0.00	0.19	0.00	0.00	1.69	23.12	0.00	0.38	0.38	0.00	0.19	0.00	5.64	15.60	0.00	3.20	0.19	0.38	0.00	0.19	0.00	0.38	0.19	0.00	0.00		
0.08	10.96	1	967	1934	.50-.355	0.31	0.00	0.10	2.59	29.58	0.00	0.00	0.00	2.59	34.54	0.00	0.00	0.41	0.10	0.00	1.14	12.72	0.00	1.76	3.21	5.27	0.00	0.00	0.41	0.00	4.55	0.10	0.62	0.00		
0.08	10.96	3	755	6040	.355-.250	1.72	0.00	0.00	1.85	24.37	0.00	0.13	0.00	3.05	33.38	0.26	0.00	0.00	1.06	0.00	1.06	11.52	0.53	2.65	4.64	4.90	0.00	4.37	0.00	3.44	0.26	0.79	0.00			
			total frequency (%)			1.25	0.00	0.10	2.48	27.20	0.00	0.14	0.00	2.79	32.17	0.18	0.03	0.02	0.82	0.03	0.00	1.57	12.39	0.36	2.43	3.90	4.55	0.00	3.10	0.00	3.51	0.22	0.75			
sample number: AU 12			water depth: 11 m														sediment terminology: clay-silt										carbonate content: 36.5%									

Appendix 1 (continued): Data (%) of component analysis.

sample number: AU 13				water depth: 8 m	sediment terminology: clay-silt																	carbonate content: 42%												
sediment weight (g)	weight % (>250µm)	counted grains	calculated grain no.	grain size (mm)	carbonate rock f.	quartzsandstone f.	quartz	gastropods	bivalves	polyplacophors	scaphopods	pteropods	echinoids	ophiurds	holothurians	balanids	decapods	ostracods	bryozoa	brachiopods	serpuids	parchment-like tubes	hyaline forams	miliolid forams	agglutinated forams	red algae	sponge spicules	plant remains	vertebrates	pellets	tar clumps	unidentified		
4.60	88.29	0	85	>2	0.00	0.00	5.88	77.65	0.00	3.53	0.00	4.71	0.00	0.00	0.00	0.00	0.00	0.00	0.00	0.00	0.00	2.35	3.53	0.00	0.00	0.00	0.00	0.00	0.00	0.00	1.18	0.00	0.00	1.18
0.12	2.30	0	81	2-1.4	0.00	0.00	2.47	66.67	0.00	2.47	0.00	1.23	1.23	0.00	0.00	0.00	0.00	0.00	0.00	0.00	0.00	2.47	14.81	0.00	0.00	0.00	0.00	0.00	0.00	0.00	8.64	0.00	0.00	0.00
0.11	2.11	0	185	1.4-1	0.00	0.00	4.86	60.54	0.00	2.70	0.00	1.62	3.78	0.00	0.54	0.00	0.00	0.00	2.16	0.00	1.08	15.68	2.16	1.08	0.00	0.00	0.00	0.00	2.16	0.00	0.00	1.08	0.00	0.54
0.08	1.54	0	315	1-0.71	0.00	0.00	6.03	50.48	0.00	0.32	0.00	0.95	11.11	0.00	0.32	0.63	0.00	0.63	0.00	1.59	19.68	0.32	3.17	0.32	0.00	0.00	0.00	0.00	3.17	0.00	1.27	0.00	0.00	0.00
0.10	1.92	0	973	.71-.50	0.21	0.00	3.60	41.21	0.00	0.62	0.00	7.30	16.65	0.00	0.10	0.00	0.00	0.00	3.91	0.00	0.62	12.95	0.31	2.16	0.62	0.41	0.00	0.00	8.22	0.00	0.92	0.10	0.10	0.10
0.11	2.11	1	1330	.50-.355	1.43	0.00	1.65	28.35	0.00	0.23	0.00	6.99	23.08	0.00	0.00	0.00	1.05	4.06	0.00	1.05	4.06	0.00	13.31	0.60	1.58	2.33	1.13	0.00	0.00	10.90	0.00	2.48	0.00	0.53
0.09	1.73	3	894	.355-.250	6.15	0.00	1.12	24.50	0.00	0.11	0.00	8.28	18.46	0.00	0.00	0.00	1.79	0.34	0.00	0.00	0.00	9.51	0.67	2.57	3.02	1.12	0.00	0.00	21.70	0.00	0.34	0.00	0.22	
total frequency (%)					4.19	0.00	0.07	1.69	28.80	0.00	0.27	0.00	7.51	18.68	0.00	0.03	0.02	1.36	1.54	0.00	0.22	11.06	0.63	2.26	2.49	1.00	0.00	0.00	16.97	0.01	0.92	0.01	0.29	
sample number: AU 14					sediment terminology: sandy clay-silt																	carbonate content: 42%												
3.99	62.83	0	130	>2	0.00	0.00	5.38	83.08	0.00	0.77	0.00	0.77	0.00	0.00	0.00	0.00	0.00	0.00	0.00	0.00	3.08	4.62	0.00	0.00	0.00	0.00	0.00	0.77	0.00	0.00	0.00	0.00	0.00	0.77
0.22	3.46	0	118	2-1.4	0.00	0.00	5.93	69.49	0.00	2.54	0.00	0.00	0.85	0.00	1.69	0.00	0.00	0.00	0.00	0.00	1.69	5.93	0.00	0.00	1.69	0.00	0.00	0.00	6.78	0.00	0.00	0.00	0.00	3.39
0.21	3.31	0	334	1.4-1	0.30	0.00	6.59	62.57	0.00	0.60	0.00	1.50	0.60	0.00	0.30	1.20	0.00	0.00	0.00	1.20	10.18	2.10	10.18	2.10	0.60	0.30	0.00	0.00	11.98	0.00	0.00	0.00	0.00	0.00
0.22	3.46	0	861	1-0.71	0.46	0.00	5.23	46.46	0.00	0.35	0.00	0.58	4.53	0.00	0.12	0.46	0.00	0.00	0.00	0.00	0.23	24.04	0.70	7.78	0.35	0.00	0.00	4.53	0.00	3.95	0.12	0.12	0.12	0.12
0.27	4.25	0	2542	.71-.50	4.25	0.16	5.43	34.23	0.00	0.28	0.00	2.40	7.20	0.00	0.04	0.39	0.00	0.00	0.00	0.00	0.51	10.54	0.79	7.24	0.87	0.08	0.00	0.00	21.36	0.04	3.97	0.12	0.12	0.12
0.39	6.14	3	1127	.50-.355	20.05	0.09	2.48	20.50	0.00	0.27	0.00	1.15	6.39	0.00	0.00	0.00	0.80	0.00	0.00	0.00	0.44	6.52	1.24	2.66	2.13	0.62	0.00	0.00	28.57	0.00	3.37	0.00	0.44	
1.05	16.54	6	32448	.355-.250	61.14	0.39	2.17	9.99	9.27	0.00	0.00	0.79	4.73	0.00	0.00	0.00	1.38	0.00	0.00	1.38	0.00	0.39	3.55	0.00	3.95	1.78	0.20	0.00	7.30	0.00	2.37	0.20	0.00	
total frequency (%)					47.88	0.31	1.60	1.68	14.36	0.00	0.09	0.00	0.95	5.14	0.00	0.01	0.04	1.14	0.00	0.00	0.42	5.33	0.32	3.48	1.75	0.27	0.00	0.00	12.27	0.00	2.66	0.15	0.11	

Appendix 1 (continued): Data (%) of component analysis.

sample number: AU 15				water depth: 4 m														sediment terminology: sandy clay-silt														carbonate content: 43.5%													
sediment weight (g)	weight % (>250µm)	splits	counted grains	calculated grain no.	grain size (mm)	quartzsandstone f.	quartz	gastropods	bivalves	polylacophors	scaphopods	pteropods	echinoids	ophiurids	holothurians	balanids	decapods	ostracods	bryozoa	brachiopods	serpulids	parchemt-like tubes	agglutinated tubes	hyaline forams	milloid forams	agglutinated forams	red algae	sponge spicules	plant remains	vertebrates	pellets	tar clumps	unidentified												
						0.06	0.05	0.08	0.10	0.15	0.41	1.77	0.00	0.00	0.00	0.00	0.00	0.00	0.00	0.00	0.00	0.00	0.00	0.00	0.00	0.00	0.00	0.00	0.00	0.00	0.00	0.00	0.00	0.00	0.00	0.00	0.00	0.00							
2.91	59.63	0	89	89	>2	4.49	0.00	6.74	77.53	0.00	0.00	0.00	0.00	0.00	0.00	0.00	0.00	0.00	1.12	0.00	0.00	1.12	0.00	0.00	0.00	0.00	0.00	0.00	0.00	0.00	0.00	0.00	0.00	0.00	0.00										
0.20	4.10	0	115	115	2-1.4	0.87	0.00	16.52	47.83	0.00	0.00	0.00	0.00	0.00	0.00	0.00	0.00	1.74	0.00	0.87	0.00	2.61	7.83	0.00	0.00	0.00	0.00	0.00	0.00	0.00	0.00	0.00	0.00	0.00	0.00										
0.15	3.07	0	197	197	1.4-1	4.06	0.00	12.18	48.22	0.00	0.00	0.00	1.52	0.00	0.00	0.00	0.00	0.00	0.00	0.00	0.51	0.00	1.52	1.02	0.00	0.00	0.00	0.00	0.00	0.00	0.00	0.00	0.00	0.51	4.06										
0.04	0.82	0	153	153	1-0.71	11.11	0.00	8.50	35.29	0.00	0.00	0.00	0.00	0.00	0.00	0.00	0.65	0.00	0.00	0.00	0.00	6.54	3.27	3.92	0.00	0.00	0.00	0.00	0.00	0.00	0.00	0.00	0.00	0.00	0.65										
0.08	1.64	0	718	718	.71-.50	12.87	0.00	3.34	24.79	0.00	0.00	0.00	0.14	0.42	0.00	0.00	0.00	0.00	0.14	0.00	0.14	6.82	2.23	2.79	0.28	0.00	0.00	0.00	0.00	0.00	0.00	0.00	0.00	0.00	1.53										
0.40	8.20	3	503	4024	.50-.355	38.57	0.99	1.19	0.80	7.16	0.00	0.00	0.00	0.20	0.00	0.00	0.00	0.20	0.00	0.00	10.54	1.79	0.40	0.20	0.00	0.00	0.00	0.00	0.00	0.00	0.00	0.00	0.80	0.40											
1.10	22.54	5	828	26496	.355-.250	66.06	0.00	1.81	0.60	2.42	0.00	0.00	0.12	0.00	0.00	0.00	0.00	0.36	0.00	0.00	0.00	2.17	0.00	0.24	0.00	0.12	0.00	0.00	0.00	0.00	0.00	0.36	0.12	0.60											
total frequency (%)								60.32	0.13	1.66	0.87	4.34	0.00	0.11	0.03	0.00	0.01	0.33	0.01	0.00	0.02	3.36	0.30	0.34	0.03	0.10	0.00	0.00	0.00	0.00	0.00	0.00	0.00	0.00	0.62										
sample number: AU 16				water depth: 3 m														sediment terminology: clayey-sandy silt														carbonate content: 37%													

Appendix 1 (continued): Data (%) of component analysis.

sample number: AU 17				water depth: 0.5 m													sediment terminology: gravelly sand													carbonate content: 72%												
sediment weight (g)	weight % (>250µm)	splits	counted grains	calculated grain no.	grain size (mm)	carbonate rock f.	quartzsandstone f.	quartz	gastropods	bivalves	polyplacophors	scaphopods	pteropods	echinoids	ophiurids	holothurians	balanids	decapods	ostracods	bryozoa	brachiopods	serpulids	parchment-like tubes	hyaline forams	milloid forams	agglutinated forams	red algae	sponge spicules	plant remains	vertebrates	pellets	tar clumps	unidentified									
0.20	0.40	0	11	11	>2	9.09	9.09	0.00	9.09	63.64	0.00	0.00	0.00	0.00	0.00	0.00	0.00	0.00	0.00	0.00	0.00	0.00	0.00	0.00	0.00	0.00	0.00	0.00	0.00	0.00	0.00	0.00	0.00	0.00								
0.06	0.12	0	23	23	2-1.4	21.74	0.00	0.00	0.00	56.52	0.00	0.00	0.00	0.00	0.00	0.00	0.00	0.00	0.00	0.00	0.00	8.70	0.00	0.00	0.00	0.00	0.00	0.00	13.04	0.00	0.00	0.00	0.00	0.00								
0.08	0.16	0	53	53	1.4-1	56.60	3.77	1.89	5.66	26.42	0.00	0.00	0.00	0.00	0.00	0.00	0.00	1.89	0.00	0.00	0.00	0.00	0.00	0.00	0.00	0.00	0.00	0.00	0.00	0.00	0.00	0.00	1.89	1.89								
0.22	0.45	0	322	322	1-0.71	68.94	1.55	0.00	2.17	12.42	0.00	0.00	0.31	0.00	0.00	0.00	0.00	0.00	0.00	0.00	0.00	1.24	1.24	0.62	0.31	0.00	0.00	0.00	1.86	0.00	6.83	0.00	2.17									
1.15	2.33	2	1091	4364	.71-.50	92.12	0.18	1.28	0.18	1.19	0.00	0.00	0.00	0.00	0.00	0.00	0.00	0.00	0.00	0.00	0.00	0.09	0.18	0.00	0.00	0.00	0.00	0.00	0.27	0.00	3.94	0.00	0.55									
9.21	18.64	7	773	98944	.50-.355	95.47	0.65	2.93	0.00	0.26	0.00	0.00	0.00	0.00	0.00	0.00	0.00	0.00	0.00	0.00	0.00	0.00	0.00	0.00	0.00	0.00	0.00	0.00	0.00	0.00	1.16	0.00	0.13									
38.49	77.90	11	442	905216	.355-.250	95.48	0.45	4.07	0.00	0.00	0.00	0.00	0.00	0.00	0.00	0.00	0.00	0.00	0.00	0.00	0.00	0.00	0.00	0.00	0.00	0.00	0.00	0.00	0.00	0.00	0.00	0.00	0.00									
total frequency (%)				total frequency (%)				total frequency (%)				total frequency (%)				total frequency (%)				total frequency (%)				total frequency (%)				total frequency (%)				total frequency (%)										
sample number: AU 18				sample number: AU 18				sample number: AU 18				sample number: AU 18				sample number: AU 18				sample number: AU 18				sample number: AU 18				sample number: AU 18				sample number: AU 18				sample number: AU 18						
water depth: 1 m				water depth: 1 m				water depth: 1 m				water depth: 1 m				water depth: 1 m				water depth: 1 m				water depth: 1 m				water depth: 1 m				water depth: 1 m				water depth: 1 m						
sediment terminology: sand				sediment terminology: sand				sediment terminology: sand				sediment terminology: sand				sediment terminology: sand				sediment terminology: sand				sediment terminology: sand				sediment terminology: sand				sediment terminology: sand				sediment terminology: sand						
carbonate content: 79%				carbonate content: 79%				carbonate content: 79%				carbonate content: 79%				carbonate content: 79%				carbonate content: 79%				carbonate content: 79%				carbonate content: 79%				carbonate content: 79%				carbonate content: 79%						

Appendix 1 (continued): Data (%) of component analysis.



# ZOBODAT - [www.zobodat.at](http://www.zobodat.at)

Zoologisch-Botanische Datenbank/Zoological-Botanical Database

Digitale Literatur/Digital Literature

Zeitschrift/Journal: [Beiträge zur Paläontologie](#)

Jahr/Year: 1994

Band/Volume: [18](#)

Autor(en)/Author(s): Zuschin Martin, Piller Werner E.

Artikel/Article: [Sedimentology and facies zonation along a transect through the Gulf of Trieste, Northern Adriatic Sea 75-114](#)