

Monitoring the Chemical Grouting in Sandy Soil by Electrical Resistivity Tomography (ERT)

PHAM HUY GIAO¹, NGUYEN QUOC CUONG¹ and MENG HENG LOKE²

¹ Geo-Exploration and Petroleum Geoengineering (GEPG) Program, Asian Institute of Technology (AIT), Bangkok, Thailand.

² Adjunct faculty of AIT & Geotomo Software, Malaysia.

hgiao@ait.asia

Abstract

An experimental study was carried out to investigate the applicability of Electrical Resistivity Tomography (ERT) in monitoring the changes brought by the injection of chemical permeation grouting into a sandy soil. First, a sand tank was constructed in the laboratory for the grouting injection test. The tank is of 30x30x60 cm size and filled with a sandy soil compacted to optimum moisture of 9%. To make the grouting solution, sodium silicate (Na_2SiO_3) was mixed with a reactant of formamide (HCOONH_2) and water by the ratio 25:3:2, respectively, to form a gel. 3D forward modeling and model-based inversion were conducted to understand the behavior of the injected soil and to find out the most suitable electrode configuration. Monitoring by ERT was then conducted using crosshole bipole-bipole and four gradient electrodes arrays. Even though the correction for the finite size effect of the tank was not yet applied to the measured data, the resistivity inversion results could accurately delineate the grouted part. The findings from this geotechnical-geophysical experimental study are useful for the implementation of a larger scale ERT monitoring of chemical grouting process in the field conditions in Bangkok.

Introduction

Grouting is the process in which a liquid is forced under pressure into the voids of soils, where the liquid will solidify by physical or chemical action. The injection of grout into the void space is used to block water movement and increase the strength of the treated material. Grouting is applicable mainly to cohesionless soils that are relatively permeable. However, one problem with grouting is that there is no good way to control the shape and location of the grout body, and injection of the grout often turns out to be a random operation. Therefore, in many occasions leakage occurs because the grout body is not in the right location. Other failures are linked to the fact that the grout body is too thin or not strong enough, or the grout body is discontinuous. So monitoring and mapping are useful to check the quality of grouting and provide an early warning for failure of geotechnical works (EWANIC et al., 1999). Although Electrical resistivity tomography (ERT) is not an easy technique to be applied it can be quite useful for geoenvironmental applications (WILKINSON et al., 2008; ZHOU and GREENHALGH, 1997, 2000). In this study a laboratory experimental model using the sand tank was built to simulate the grouting process and ERT was employed to monitor and assess the behavior of the grouted space.

Preparatory tests

A series of geotechnical and chemical tests were conducted in precedence of the main experiment as described below:

Grain size distribution test: Sand was selected as the soil to be grouted. The grain size distribution of this testing sandy soil was found by the sieve analysis as shown in Fig. 1.

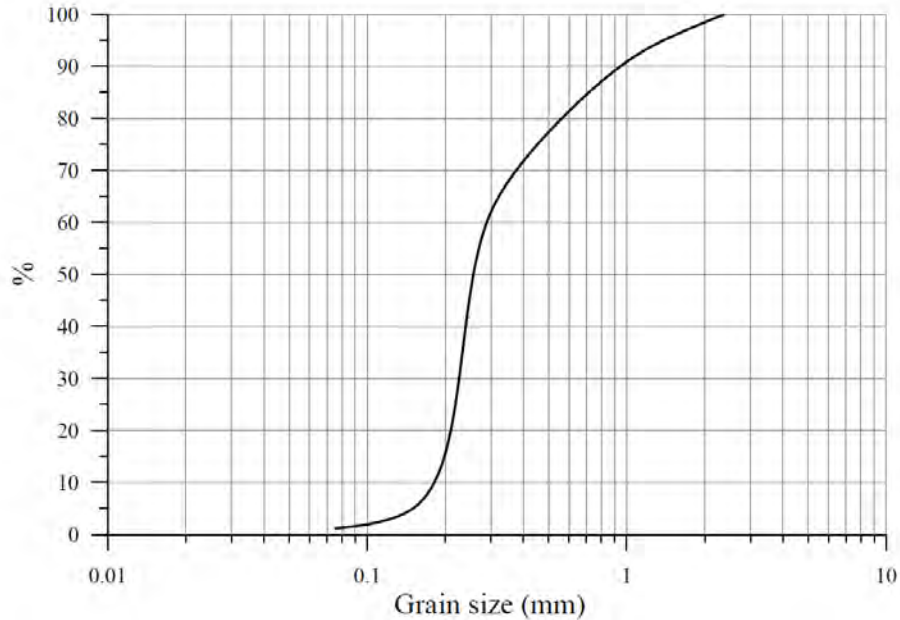

Fig.1: Grain size distribution of the sandy soil.

Compaction test: The standard proctor test with a mold having a volume 943.4 cm^3 was conducted to obtain the maximum dry unit weight and the optimum moisture content. The results are shown in Fig. 2.

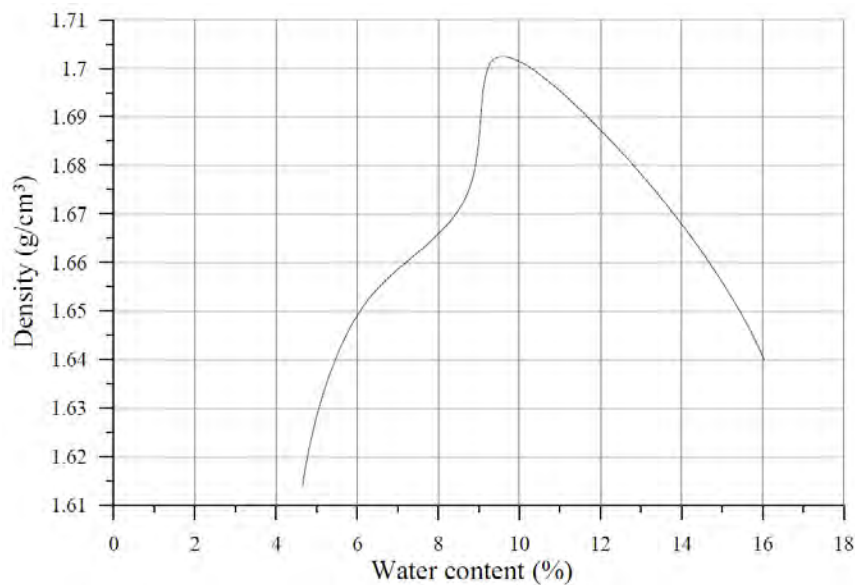

Fig. 2: Results of compaction test.

Preparation of grouting solution: The grouting solution mainly consists of sodium silicate as the gel-forming material and formamide (HCOONH_2) as the reactant. Two solutions are prepared and mixed thoroughly in the so called one-solution process. Sodium silicate is alkaline that is neutralized by the reactant, and colloidal silica will aggregate to form a gel. The main properties of Sodium silicate (Na_2SiO_3) N44 include: mole ratio from 3 to 3.2; percentage of Na_2O : 10 to 11%; percentage of SiO_2 : 30 to 32%; specific gravity at 20°C : 1.420-1.450; density at 20°C : 1.38 g/cm^3 ; pH: 11.3; viscosity: 180cps;

Measuring the grouting material resistivity

Information on electric resistivity of sand, grout and grout-sand mixture are of primary importance in analysis of ERT data. The grout material is made of Sodium silicate mixed with formamide (HCOONH_2) and water by the ratio: 25:3:2. The gel time is 6 hours. For measurements of resistivity the grout material is prepared in form of core samples. The measuring scheme follows the setup shown in Fig. 3.

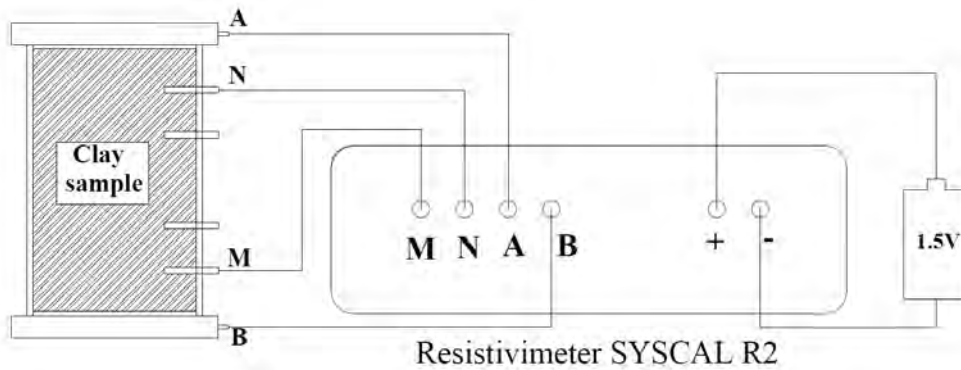

Fig. 3: Setup to measure electric resistivity on a core sample (GIAO et al., 2003).

The resistivity test results are plotted in Fig. 4 that shows the change of grout resistivity with time. At the beginning the resistivity was $0.3 \Omega\text{m}$, and then it has gradually increased to $0.55 \Omega\text{m}$ after 15 hours, and remained almost constant after that.

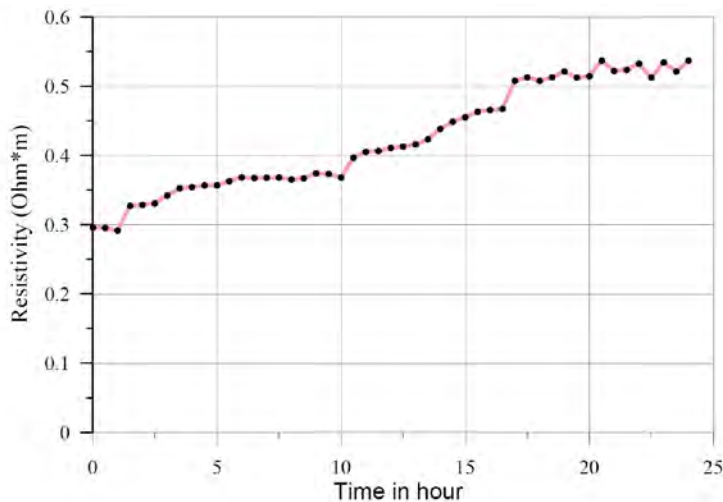

Fig. 4: Resistivity of grouting material vs. time.

Measuring the grouting material conductivity

The conductivity meter HI 9835 was used to directly measure the electrical conductivity of the grouting solution that was poured in a glass. The conductivity unit σ is in $S.m^{-1}$. As the reciprocal of the conductivity is the resistivity one could determine the resistivity as follows:

$$(1) \rho = 1/\sigma$$

Where: ρ is the resistivity ($\Omega.m$) and σ is the conductivity (S/m).

The measurements were conducted during 24 hours for different states of solution, from liquid gel to solid. The resistivity values converted from conductivity measurements are plotted in Fig. 5, where the grout resistivity is found as the $0.55 \Omega.m$, similar to the value obtained by measurements performed on the cores.

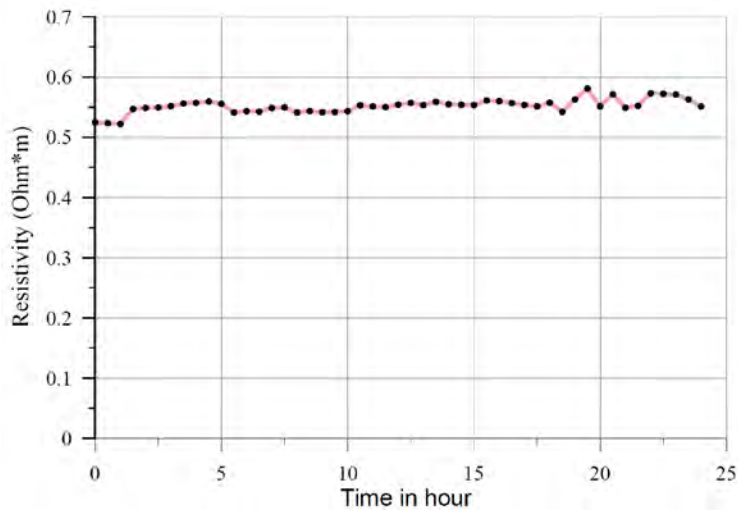

Fig. 5: Resistivity measured by conductivity meter.

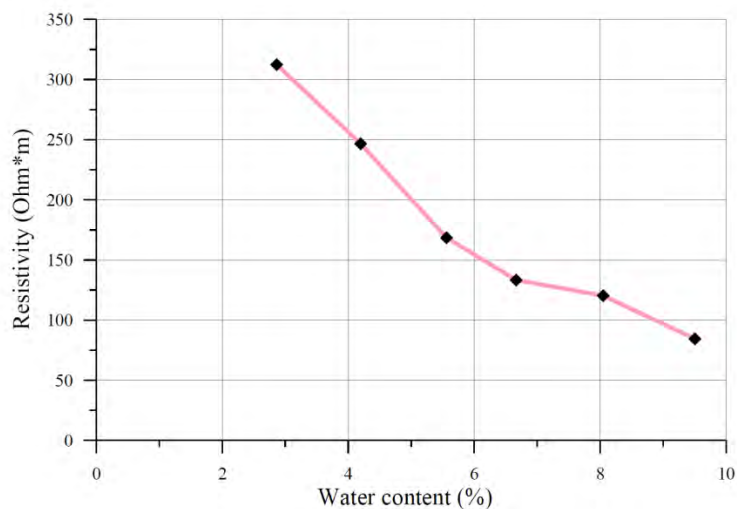

Fig. 6: Resistivity of compacted sand

The to-be-grouted sand is compacted in a PVC mold having a 43-mm diameter and a 100-mm length. Samples were prepared for different water contents, from 3 to 10% with the increment of 1.5%. The sand resistivity was measured by the setup shown in Fig. 3 and the measurements are

plotted in Fig. 6, which shows a decreasing sand resistivity with the increasing water content. At the optimum water content of 9% (Fig. 2) the resistivity is about 100 Ω m as seen in Fig. 6. Before conducting the real experiment of grouting injection and its accompanied monitoring by ERT a series simulations were performed to investigate the response of the tank model and, finally, to find out the number of electrodes and type of electrode array to be employed. Details and results of such forward and inverse analyses are presented in the following section.

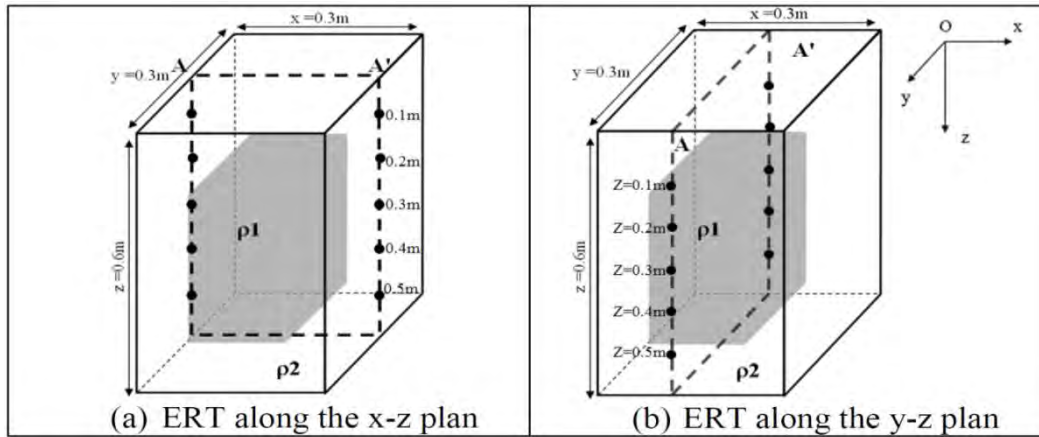

Fig. 7: Simulation of ERT monitoring on the synthetic grouting model.

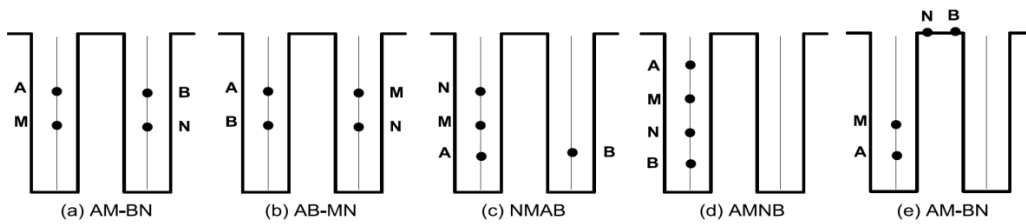

Fig. 8: ERT electrodes arrays: (a-b) Bipole-bipole; (c) Four-electrode gradient array; (d) Wenner – Schlumberger in the same borehole; (e) Surface-to-borehole.

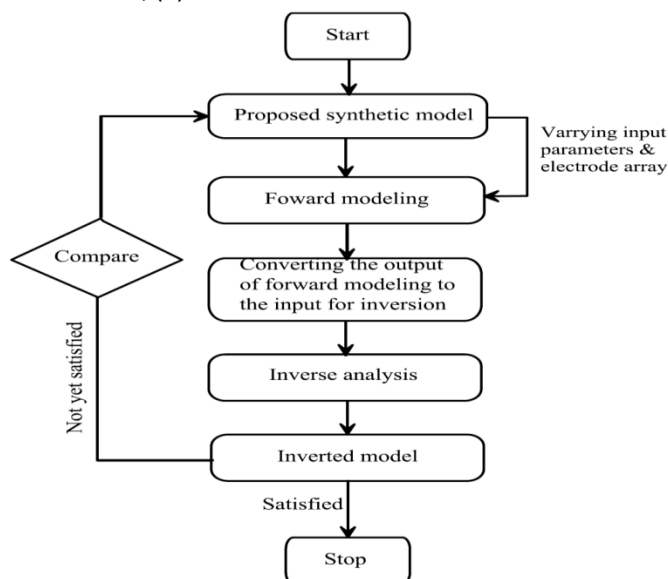

Fig. 9: Flowchart of model-based resistivity inversion.

Synthetic model	Array type	Electrode spacing (m)	Resistivity (Ωm)	Nos. of electrode per line	Number of ERT points	Plane	Abs. Error (%)
1	Bipole–Bipole AM-BN	AM = BN = 0.1, 0.2, 0.3	$\rho_1 = 0.55$; $\rho_2 = 100$	5	120	XZ	1.20
						YZ	1.18
2	Bipole–Bipole AB-MN	AB = MN = 0.1, 0.2, 0.3	$\rho_1 = 0.55$; $\rho_2 = 100$	5	111	XZ	3.69
						YZ	3.45
3	Four- electrode gradient array NMAB	MN = 0.1, 0.2, 0.3	$\rho_1 = 0.55$; $\rho_2 = 100$	5	50	XZ	10.90
						YZ	6.98
4	Borehole to Surface AM-BN	AM = BN = 0.1, 0.2, 0.3	$\rho_1 = 0.55$; $\rho_2 = 100$	5	160	XZ	1.06
						YZ	0.81
5	Bipole–Bipole AM-BN	AM = BN = 0.1, 0.2, 0.3	$\rho_1 = 0.55$; $\rho_2 = 100$	11	1532	XZ	0.76
						YZ	0.64
6	Bipole–Bipole AB-MN	AB = MN = 0.1, 0.2, 0.3	$\rho_1 = 0.55$; $\rho_2 = 100$	11	1036	XZ	4.86
						YZ	0.75
7	4-electrode gradient array NMAB	MN = 0.1, 0.2, 0.3	$\rho_1 = 0.55$; $\rho_2 = 100$	11	1037	XZ	0.77
						YZ	0.45
8	Wenner–Schlumberger in the same borehole AMNB	a = MN = 0.1, 0.2, 0.3	$\rho_1 = 0.55$; $\rho_2 = 100$	11	45	XZ	1.71
						YZ	0.98
9	Borehole to Surface AM-BN	AM=BN = 0.1, 0.2, 0.3	$\rho_1 = 0.55$; $\rho_2 = 100$	11	1320	XZ	0.99
						YZ	0.69

Tab. 1: Synthetic models for forward modeling and model-based inversion.

Simulation of ERT monitoring

The material properties tested in the first part of the experiment as mentioned before were used to construct a synthetic grouting model as shown in Fig. 7. The tank sizes are of 0.3 x 0.3 x 0.6 m in the x, y and z directions, respectively. Resistivity of the grouting material (i.e., Sodium silicate mixed with formamide) is taken as $\rho_1 = 0.55 \Omega\text{m}$. Resistivity of grouted sand is taken as $\rho_2 = 0.55 \Omega\text{m}$. Two pairs of boreholes were employed for ERT monitoring in the model, one in the X-Z plane and another one in the Y-Z plane as seen in Fig. 7a and 7b, respectively. The electrode arrays of Bipole-bipole, four-electrode gradient, Wenner-Schlumberger and surface-to-borehole as shown in Fig. 8 were considered. The array that gives the best ERT response can be assessed based on a model-based inversion (see Fig. 9) that included the following steps: i) firstly, a synthetic model was constructed, having the same sizes of the real tank to be tested in the grouting experiment; ii) the forward modeling was then run to simulate the ERT monitoring of the grouting process using RES3DMOD software (LOKE, 2011a); iii) the resistivity values computed from the forward modeling are used as the synthetic measurements (model responses) in the input file for the inversion using RES3DINV software (LOKE, 2011b); iv) input parameters and electrode array type

can vary and the best inverted resistivity distribution is the one that resembles the constructed grouting model the most.

Various scenarios of simulation with 5 and 11 electrodes as presented in Table 1 were conducted. Some of the simulation results of ERT monitoring with 5-electrode array are shown in Figs. 10a-d. It was found out that the bipole-bipole (AM-BN) and four gradient electrodes (MNAB) gave the best response. Thus, they were elected to be employed in the subsequent monitoring experiment phase in the laboratory.

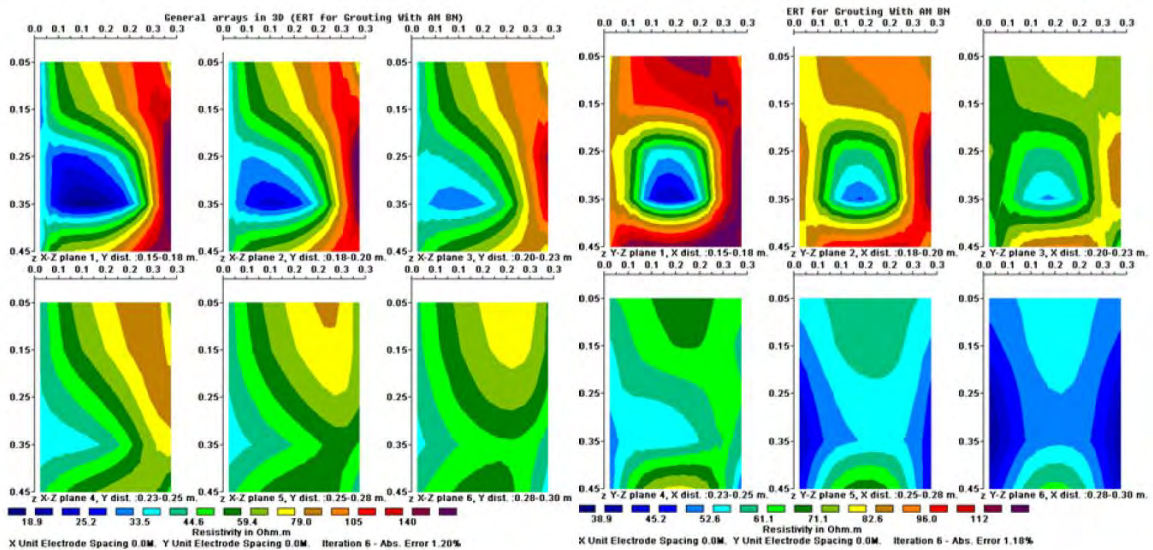

(a) Bipole-bipole AMBN, x-z plane

(b) Bipole-bipole AMBN, y-z plane

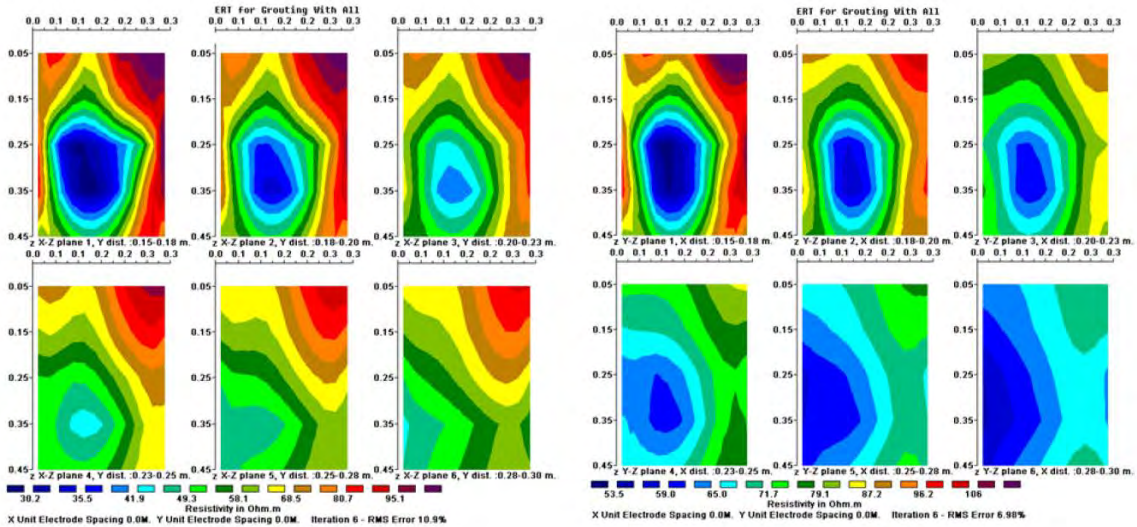

(c) Four gradient electrode array, x-z plane

(d) Four gradient electrode array, y-z plane

Fig. 10: Model-based inversion of the synthetic measurements simulated by forward modelling.

Laboratory experiment of grouting injection and ERT monitoring

Grouting Injection Test

The test setup can be seen in Figs. 11 and 12, respectively. Sand was volumetrically compacted to 90% of that found from the compaction test. The main operations included: (i) mixing one litter of grout of sodium silicate, formamide (reactant) and water at the ratio of 25:3:2 and pouring it into

the chamber; (ii) connecting the tube between the chamber and air pressure and steel chamber with injection tube; (iii) installing the injection tube into the sand tank and make sure that it does not touch the bottom of the tank. The air release valve and shut-off valve are used to control the pressure pumping the grout into the sand. Sodium silicate grout with low viscosity will fill the voids without disturbing the structure of sandy soil.

ERT Monitoring

Electrodes are installed on the four sides of the sand tank with 5 electrodes per one side and 10 cm apart as viewed in Fig. 12. Firstly, the measurements on two opposite sides were conducted, and then the measurements were repeated in a similar way on the other opposite sides. The cross-hole bipole-bipole AM–BN was employed in the experiment.

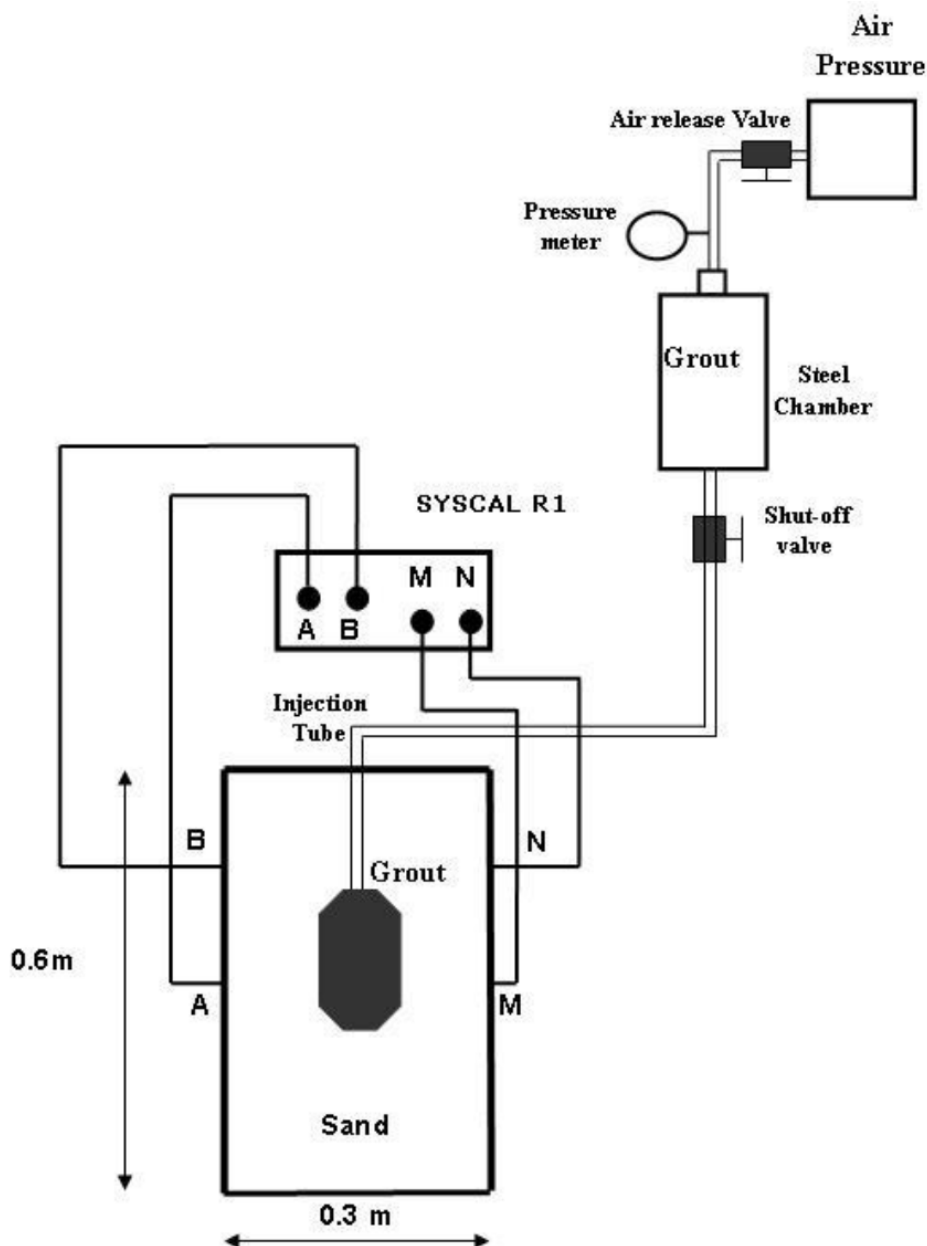

Fig. 11: Setup of grouting and ERT test.



Fig. 12: View of the grouting and ERT setup.

The inversion was done using RES3DINV program (LOKE, 2011b). The inverted resistivity slices are shown in Fig. 13 for different ERT times of grouting, i.e., at the beginning, after 4 hours and after 12 hours. Each figure (Fig. 13a, b and c) displays slices of X-Z plane cut at different Y-coordinate values, i.e., 0.15m, 0.18m, 0.23m, 0.25m, 0.28 m and 0.30m, respectively. The best results of ERT monitoring were obtained by the bipole-bipole AMBN array, which show that in the first period when the grouting was just injected to the sand tank, the grout body of very low resistivity is quite clearly seen with a good resistivity contrast in comparison to the base material. After four hours the grouted body sank down towards the bottom of the tank due to the gravity. After 12 hours, the grouted sand body continued moving down to the bottom of the tank until it become solid and gets a well-defined shape as seen in Figs. 13a-c, respectively.

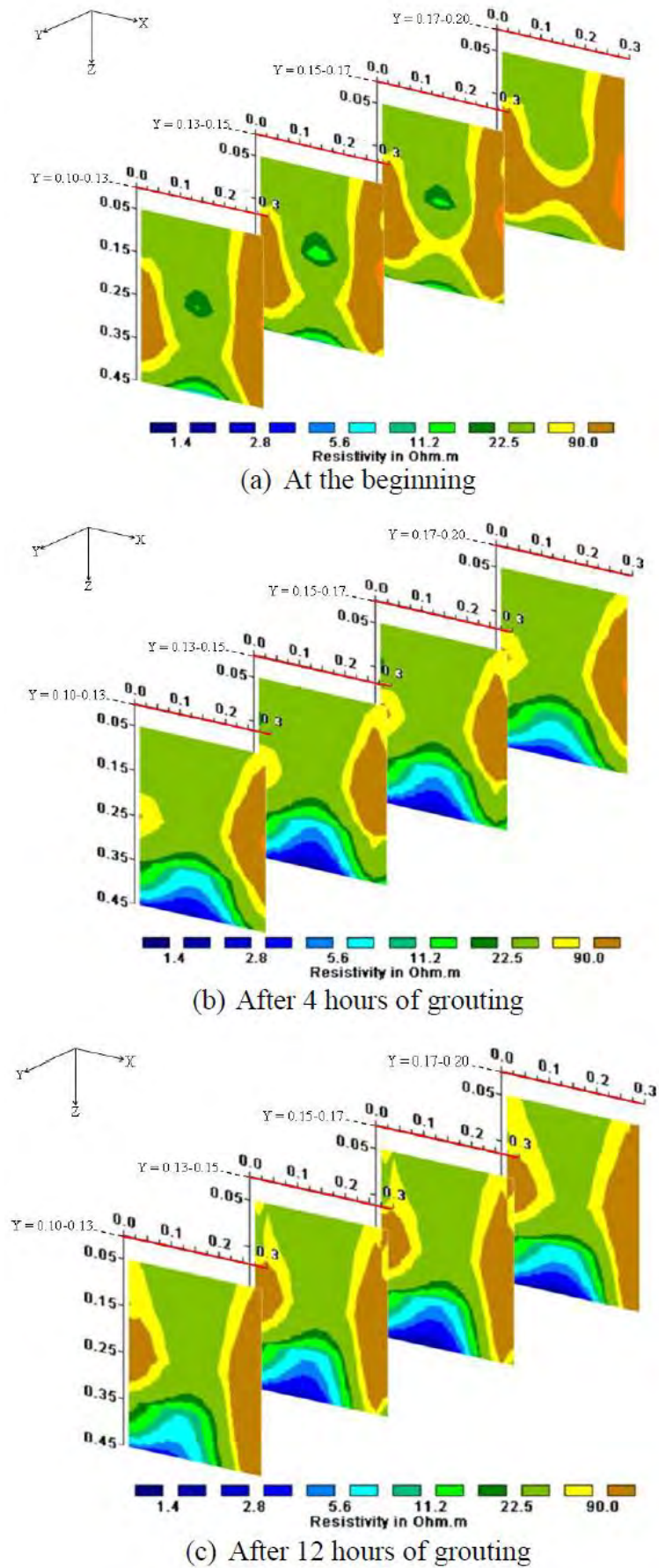

Fig. 13: Results of inversion of real resistivity data by bipole-bipole AMBN array.

Conclusions

Electrical Resistivity Tomography (ERT) proved to be effective in monitoring the chemical permeation grouting in a sand tank due to the clear contrast in resistivity between the grouting material and the base material. In this study experiment, the grouting material is a mixed of sodium silicate (Na_2SiO_3), formamide (HCOONH_2) and water by the ratio: 25:3:2 and has a low resistivity of 0.55 Ωm . The base sandy soil has a resistivity of about 100 Ωm at the optimum water content of 9%. A number of electrode arrays were used in ERT and it was found that the cross-borehole bipole-bipole configuration is good to determine the shape of the grout body and the movement of the grout solution inside the sand. As the measurements of resistivity on the tank model were clearly affected by its finite sizes of the tank the resistivity values need to be corrected before being input for inversion, which can be practically solved. It is recommended that similar setup of ERT will be further developed and applied in the field conditions in geotechnical practice in Bangkok.

References

- GIAO, P.H., CHUNG, S.G., KIM, D.Y. and TANAKA, H., 2003: Electric imaging and laboratory resistivity testing for geotechnical investigation of Pusan clay deposits. – *Journal of Applied Geophysics*, **52**(4), p. 157-175.
- EWANIC, M., REICHHARDT, D. and BRUNETTE, B.S., 1999: Electrical Resistivity Tomography Imaging of a Colloidal Silica Grout Injection. – U.S. Department of Energy (DOE).
- LOKE, M.H., 2011a: RES3DMOD, 3D resistivity forward modeling using the finite difference and finite element methods, <http://www.geotomosoft.com>
- LOKE, M.H., 2011b: RES3DINV, 3D resistivity inversion using the finite difference and finite element methods, <http://www.geotomosoft.com>
- WILKINSON, P.B., CHAMBERS, J.E., LELLIOT, M., WEALTHALL, G.P. and OGILVY, R.D., 2008: Extreme Sensitivity of Crosshole Electrical Resistivity Tomography Measurements to Geometric Errors. – *Geophysical Journal International*, **173**, 49-62.
- ZHOU, B. and GREENHALGH, S.A., 1997: A synthetic study on cross-hole resistivity imaging with different electrode arrays. – *Exploration Geophysics*, **28**, 1-5.
- ZHOU, B. and GREENHALGH, S.A., 2000: Cross-hole resistivity tomography using different electrode configurations. – *Geophysical Prospecting*, **48**, 887-912.

ZOBODAT - www.zobodat.at

Zoologisch-Botanische Datenbank/Zoological-Botanical Database

Digitale Literatur/Digital Literature

Zeitschrift/Journal: [Berichte der Geologischen Bundesanstalt](#)

Jahr/Year: 2012

Band/Volume: [93](#)

Autor(en)/Author(s): Giao Pham Huy, Guong Nguyen Quoc, Loke Meng Heng

Artikel/Article: [Monitoring the Chemical Grouting in Sandy Soil by Electrical Resistivity Tomography \(ERT\). 168-178](#)